

**CTDOT PROJECT #87-146  
RUBBER AVENUE AT HOADLEY STREET AND  
MELBOURNE STREET TRAFFIC SIGNAL  
REPLACEMENT PROJECT  
NAUGATUCK, CONNECTICUT**

**Contract No. 19-87-145**

**CONTRACT DOCUMENTS**

**PREPARED BY THE  
BOROUGH OF NAUGATUCK  
CONNECTICUT**

**January 2019**



**BOROUGH OF NAUGATUCK**  
**INVITATION TO BID**

**Borough of Naugatuck**

Sealed bids are invited and will be received by the Purchasing Agent, until 11:00 a.m., Wednesday, February 13, 2019 at the Town Hall, 229 Church Street, Naugatuck, CT and will be publicly opened and read aloud in the Hall of Burgesses, located on the 4<sup>th</sup> floor for the following:

**Contract No. 19-87-145      CTDOT PROJECT #87-146**  
**RUBBER AVENUE AT HOADLEY STREET AND**  
**MELBOURNE STREET TRAFFIC SIGNAL**  
**REPLACEMENT PROJECT**

The Contract Documents may be examined at the Office of the Purchasing Agent, Town Hall, 229 Church Street, Naugatuck, CT 06770.

Copies of Contract documents may be obtained at the Office of the Purchasing Agent upon submission of a non-refundable plan deposit in the form of a check or money order payable to the Borough of Naugatuck in the amount of **Five Hundred Dollars (\$500.00)** per set. Contract Documents can also be obtained at no cost from the Borough of Naugatuck web site <http://www.naugatuck-ct.gov> All firms obtaining Contract Documents from the web site must submit contact information by e-mail to [whozer@naugatuck-ct.gov](mailto:whozer@naugatuck-ct.gov). Contact information must be submitted three days in advance of the bid opening to be considered. Bidders must check the Naugatuck web site no more than three days prior to the bid opening to check for addendums.

The Borough of Naugatuck reserves the right to waive any informalities or to reject any or all bids.

No Bidder may withdraw his bid within (90) days after the actual date of the opening thereof.

“An Affirmative Action/Equal Opportunity Employer. Minority/Women's Business Enterprises are encouraged to apply. This contract is subject to state set-aside and contract compliance requirements.”

## **SPECIFICATIONS**

### **STANDARD SPECIFICATIONS**

The material and construction methods for the work specified in this contract shall conform with the applicable provisions of the State of Connecticut, Department of Transportation specifications entitled "*STANDARD SPECIFICATIONS FOR ROADS, BRIDGES AND INCIDENTAL CONSTRUCTION*", Form 817, 2016, as revised by the Supplemental Specifications including all Supplements (otherwise referred to collectively as "ConnDOT form 817") unless modified by the Special Provisions contained herein. "ConnDOT form 817" is hereby made part of this contract. Form 817 may be purchased from:

Connecticut Department of Transportation  
Manager of Contracts  
2800 Berlin Turnpike, Newington, Connecticut 06111

A free PDF of Form 817 is available at the following website:

<http://www.ct.gov/dot/cwp/view.asp?a=3609&q=430362>

All references to Commissioner, Department, Engineer, and State anywhere within the Form 817 shall be interpreted to mean the Borough of Naugatuck or a duly authorized agent of the Borough. Any questions or ambiguity regarding any definitions shall be brought to the immediate attention of the Borough.

## INDEX TO CONTRACT DOCUMENTS

### SECTION

---

A	Information for Bidders
B	Proposal
C	References/Qualifications
D	Bid Bond / Surety Guarantee Form
E	Contract and Agreement / Certificate as to Corporate Principal
F	Performance Bond
G	Payment Bond
H	Specifications
I	DBE Requirements
J	CTDOT Requirements (To Be Completed by Low Bidder)
K	FHWA Requirements and Prevailing Wage Rates

## SECTION A

### INFORMATION FOR BIDDERS

#### Borough of Naugatuck

#### **Contract No. 19-87-145; CTDOT PROJECT #87-146 RUBBER AVENUE AT HOADLEY STREET AND MELBOURNE STREET TRAFFIC SIGNAL REPLACEMENT PROJECT**

#### 1. Proposals Received

Sealed proposals for Disposal of Controlled Materials will be received by the Purchasing Office, Borough of Naugatuck, 229 Church Street, Naugatuck, CT 06770 until **Wednesday, February 13, 2019, at 11:00 A.M.** local time. Immediately following the bids will be publicly opened and read aloud.

#### 2. Location and Description of Work

These specifications will provide a basis for providing the Borough of Naugatuck, CT with Labor and equipment to replace the traffic signal, construct sidewalk, and incidental construction to this work at the intersection of Rubber Avenue at Hoadley Street and Melbourne Street.

#### 3. None

#### 4. Specifications

Copies of the Specifications may be seen and obtained at the Purchasing Office, Borough of Naugatuck, 229 Church Street, Naugatuck, CT 06770. The construction contract for the **Contract No. 19-87-145; CTDOT PROJECT #87-146 RUBBER AVENUE AT HOADLEY STREET AND MELBOURNE STREET TRAFFIC SIGNAL REPLACEMENT PROJECT**, will be entered into by the successful bidder and the Borough of Naugatuck. The State of Connecticut Department of Transportation Standard Specifications for Roads, Bridges and Incidental Construction, Form 817 along with supplemental specifications contained herein will detail the general requirements for materials, methods of installation, measurement and basis of payment to be required in this project. Any references to the State of Connecticut, the Department, the commissioner, Engineer, or other terms indicating the State of Connecticut and her agents as party to the contract shall for this project mean the Borough of Naugatuck and her designated agents or employees.

Where insurance is required to be carried in the name of the State of Connecticut and the State of Connecticut is to be held harmless, this shall be done in the name of the Borough of Naugatuck and the Borough of Naugatuck shall be held harmless.

It is the intent of this contract to maintain all standard requirements of Form 817 without attempting to redefine every term within the 817 to the "Borough of Naugatuck".

The bidder shall, therefore, be aware that the Borough of Naugatuck and her agents shall inspect and administrate this contract, make contract interpretations, determine the acceptability of the work and approve requests for payments. The Contractor shall be responsible for the requirements stated in Form 817 and in the construction drawings.

## 5. Addenda and Interpretations

No interpretations of the meaning of the Specifications, or other pre-bid documents will be made to any Bidder orally.

Every request for such interpretation shall be in writing, addressed to Mr. James Stewart, P.E., Borough of Naugatuck, Department of Public Works, Office, 246 Rubber Ave. Naugatuck, CT 06770. To be given consideration, such requests must be received at least six (6) days prior to the date fixed for the opening of bids. Any and all such interpretations and any supplemental instructions will be in the form of written addenda to the specifications, which, if issued, will be mailed by certified mail with return receipt requested to all prospective Bidders, at the respective address furnished for such purposes, not later than four (4) days prior to the date fixed for the opening of bids. Failure of any Bidder to receive any such addendum or interpretations shall not relieve such Bidder from any obligation under his bid as submitted. All addenda so issued shall become part of the Contract Documents.

## 6. Familiarity of the Work

Each Bidder shall fully inform himself prior to bidding as to existing conditions and limitations under which the work is to be performed, and shall include in his bid a sum to cover the cost of items necessary to perform the work as set forth in the Contract Documents. No allowance will be made to a Bidder because of lack of such examination or knowledge. The submission of a bid will be considered as conclusive evidence that the Bidder has made such examination.

The Owner assumes no responsibility whatsoever with respect to ascertaining for the Contractor such facts concerning physical characteristics at the site of the project.

The Contractor agrees that he shall make no claim for and has no right to additional payment or extension of time for completion of the work, or any other concessions, because of any interpretations or misunderstanding on his part of this Contract, or because of any failure on his part to fully acquaint himself with all conditions relating to the work.

## 7. None

## 8. Estimate of Work

For bidding purposes, the work has been subdivided into unit price items. The quantities shown below are to be considered as approximate only. The Inspector does not expressly or by implication agree that the actual quantity(ies) will correspond therewith, but reserves the right to increase or decrease the amount of any Item or portion of the work as may be deemed necessary.

## 9. Qualification of Bidders

A Bidder shall be a contractor who is experienced in controlled materials profiling, loading and authorized disposal. The Proposal shall contain adequate proof of the qualifications of the Bidder to perform, in a satisfactory manner and within the time specified, all the work covered by the Plans and Specifications. This proof shall be fully recorded on the pages titled "References", which shall become part of the Proposal.

## 10. Disqualification of Bidders

More than one proposal from an individual, firm, partnership, corporation, or an association under the same, or different, names will not be considered. Reasonable grounds for believing that any Bidder is interested in more than one proposal for the work contemplated will cause the rejection of all proposals in which such Bidder is interested. Any or all proposals in which such Bidder is interested will be rejected if there is reason for believing that collusion exists among the Bidders; and all participants in such collusion

will not be considered in future proposals for the same work. Proposals in which the prices are obviously unbalanced may be rejected. No Contract will be awarded except to competent Bidders capable of performing the class or work contemplated.

#### 11. Preparation of Proposals

The Proposal must be made upon the forms contained herein. The blank spaces in the Proposals must be filled in correctly where indicated. The Bidder must state, both in words and in numerals, written or printed in ink, the prices for which he proposes to do each Item of the work contemplated. In case of discrepancy between the words and the numerals, the words shall govern. Ditto marks are not considered writing, or printing, and shall not be used. The Bidder shall sign his Proposal correctly. If an individual makes the Proposal, his name and post office address must be shown. If made by a firm, partnership, or corporation, the Proposal must be signed by an official of the firm, partnership, or corporation authorized to sign contracts, and must show the post office address of the firm, partnership, or corporation.

Each bid must be submitted in a sealed envelope bearing on the outside the name of the Bidder, this address, and name of the project for which the bid is submitted. If forwarded by mail, the sealed envelope containing the bid must be enclosed in another envelope addressed to: Purchasing Office, Borough of Naugatuck, City Hall, 229 Church Street, Naugatuck, CT 06770.

#### 12. Irregular Proposals

The Borough of Naugatuck reserves the right to reject any proposals if they show any omission, alteration of form, additions not called for, conditional bids, or irregularities of any kind.

#### 13. Proposal Guarantee

No proposal will be considered unless accompanied by a certified check in U.S. dollars, or bid bond using an insurance company licensed to do business in the State of Connecticut in an amount of 10% of the total bid amount payable to the order of the Borough of Naugatuck, said check or bid bond to be returned to the Bidder unless forfeited as hereinafter stipulated. Such checks or bid bonds will be returned to all bidders within five (5) days after the execution of the Contract and the furnishing of the required security by the successful Bidder.

#### 14. Withdrawal of Proposals

If a Bidder wishes to withdraw his Proposal, he may do so before the time fixed for the opening of bids by communicating his purpose to the office of the Mayor. Upon such notice, the Proposal will be handed to him unopened.

#### 15. Execution of Contract

The party to whom the Contract is awarded, or his authorized representative, will be required to attend at the office of the Mayor, Borough of Naugatuck, with the sureties offered by him, or them, and a current certificate of Corporate good standing issued by the Office of the Secretary of State in which the corporation is incorporated, and execute the Contract within five (5) days from the date of the award. If the party entering into this contract is a corporation, a Corporate Resolution duly executed by the president and Secretary of the Corporation authorizing the Corporation to enter into this Contract shall be provided. In case of his failure or neglect to do so, the Owner may, at its opinion, determine that the Bidder has abandoned the Contract and thereupon the Proposal and acceptance shall be null and void, and bid security accompanying the Proposal shall be forfeited as liquidated damages to the Owner. If the party entering into this contract is a partnership, a partnership resolution duly executed by a majority of the general partners authorizing the partnership to enter into this contract shall be provided.

## 16. Bonds

The successful Bidder, at the time of the execution of the Contract, shall furnish a Performance Bond in an amount at least equal to one hundred percent (100%) of the Contract prices as security for the faithful performance of this Contract and also a Payment bond in an amount not less than one hundred percent (100%) for the Contract prices as security for the payment of all persons performing labor on the project under this Contract and furnishing materials in connection with this Contract. All Bonds shall be in the forms prescribed by Law or Regulation and be acceptable to the Owner. Surety companies executing Bonds must appear on the Treasury Department's most current list (Circular 570 as amended) and be authorized to transact business in the State of Connecticut. Bidder shall provide evidence that Surety Company is licensed to conduct business in the State of Connecticut. All sureties shall be in full force throughout the guarantee period and until the retainage is released.

## 17. None

## 18. Responsibility of the Contractor

Attention is hereby particularly directed to the provisions of the Contract and Specifications whereby the Contractor shall be responsible for any loss or damage that may happen in the work, or any part thereof, during its progress and also whereby the Contractor shall make good any defects for faults that may occur within one (1) year after date of final estimate. He shall indemnify and save harmless the Owner and Engineer from any damages or costs to which they may be put by reason of injury to the person or property of another resulting from negligence or carelessness in the performance of the work under this Contract.

## 19. Insurance

Before execution of the Contract, the Bidder will be required to file with the Borough of Naugatuck a certificate of insurance. The certificate, executed by an insurance company satisfactory to the Borough of Naugatuck shall name the Borough of Naugatuck and the State of Connecticut as additional insured parties on the form furnished with these specifications. The "Certificate of Insurance" shall state that at a minimum, with respect to the contract, the bidder carries insurance in accordance with the requirements and stipulations listed below.

Unless requested otherwise by the Borough of Naugatuck, the Bidder and its insurer shall not assert the defense of governmental immunity in the adjustment of claims or in the defense of any claim or suit brought against the Borough of Naugatuck and the State. The Bidder shall assume and pay all cost and billing for premiums and audit charges earned and payable under the required insurance.

A. Workmen's Compensation Insurance: With respect to all operations the Bidder performs and all those performed for it by subcontractors, the Bidder shall carry workmen's compensation insurance in accordance with the requirements and the laws of the State.

B. Contractor's Public Liability and Property Damage Insurance: With respect to the Project operations the Bidder performs and also those performed for it by subcontractors, the Bidder shall carry regular Contractor's Public Liability Insurance. The insurance shall provide coverage for each accident or occurrence in the amount of \$2,000,000 for all damages resulting from (1) bodily injury to, or death of, persons and/or (2) injury to or destruction of property. Subject to that limit per accident or occurrence, the policy shall provide a total or aggregate coverage of \$2,000,000 for all damages during the policy period.



C. Automobile Liability Insurance: The operation of all motor vehicles, including those hired or borrowed, used in connection with the project, shall be covered by Automobile Liability Insurance. The insurance shall provide coverage for each accident or occurrence in the amount of \$2,000,000 for all damages resulting from (1) bodily injury to, or death of, persons and/or (2) injury to or destruction of property. If an insurance policy shows an aggregate limit as part of the automobile liability coverage, the aggregate limit must be at least \$2,000,000.

D. With respect to the project operations the Bidder performs and also those performed for it by subcontractors, the Bidder shall carry for and on behalf of the Borough of Naugatuck, and State, insurance which shall provide coverage for each accident or occurrence in the amount of \$2,000,000 for all damages resulting from (1) bodily injury to or death of person and/or (2) injury to or destruction of property. Subject to that limit per accident or occurrence, the policy shall provide a total or aggregate coverage of \$2,000,000 for all damages during the policy period.

E. Railroad's Protective Liability Insurance: When the contract involves work on, over or under the right of way of any railroad company, the Bidder shall, with respect to the project operations it performs and also those performed for it by subcontractors, carry Railroad Protective Liability Insurance for and on behalf of the railroad company. The insurance shall provide coverage for each accident and occurrence in the amount of \$2,000,000 for all damages resulting from (1) bodily injury to or death of persons and/or (2) injury to or destruction of property. Subject to that limit per accident or occurrence, the policy shall provide a total or aggregate coverage of \$6,000,000 for all damages during the policy period.

F. Blasting: When explosives are to be used in the prosecution of the work, the insurance required under paragraphs b, d and e above shall also contain provisions for protection, in the amounts state, against damage claims due to such use of explosives.

G. Termination or change of Insurance: Each insurance policy shall be endorsed to provide that the insurance company shall notify the Borough of Naugatuck by certified mail at least thirty (30) days in advance of termination, or any change in the policy. No such change shall be made without prior written approval of the appropriate Official.

H. Claims: Each insurance policy shall state that the insurance company shall agree to investigate and defend the Borough of Naugatuck and State against all damages, even if groundless.

I. Compensation: There shall be no direct compensation allowed the Bidder on account of any premium or other charge necessary to take out and keep in effect all insurance or bonds, but the cost thereof shall be considered included in the general cost of the work.

## 20. Care and Protection of Property

The Contractor shall take particular care to avoid damages to all private property and to private improvements within the Boroughs' right of way. He shall make good any damages to the satisfaction of the Inspector. There shall be no additional compensation for the repair or restoration of private property, or private improvements, within the Boroughs' right of way.

## 21. Sales Tax

Certain materials and supplies incorporated in the work of this project are exempt from Connecticut Sales Tax. The Bidder shall familiarize himself with current regulations of the State Tax Department. The tax on materials or supplies exempted by such regulations shall not be included as part of the bid. The Owner will furnish the successful Bidder a sales tax exemption number.

## 22. Compliance with Federal and State Regulations

The Contractor shall be responsible for full compliance with any Federal and/or State laws, regulations and standards, as applicable to any project fully or partially funded by State and/or Federal funding agency. This project is funded, in part, by the State and Federal government.

## 23. Permits

All licenses and permits for complying with any applicable Federal, State, and Municipal laws, codes and regulations in connection with the prosecution of the work shall be obtained by the Contractor, at no additional cost to the Owner.

## 24. Sedimentation and Erosion Control Plan

The Contractor shall prepare a sedimentation and erosion control plan for the work if applicable.

## 25. Contractor's Right to Terminate Work

If the work should be stopped under an order of any court or other public authority, for a consecutive period of not less than thirty (30) days, through no act or fault of the Contractor or of anyone employed by him, then the Contractor may terminate this Contract and recover from the Owner payment for all work executed.

## 26. None

## 27. Power of Attorney

Attorneys-in-fact who sign contract bonds must file, with each bond, a certified and effectively dated copy of their power of attorney.

## 28. Right to Reject

The Owner reserves the right to reject any or all proposals or to accept any bid, should it deem it to be in the best interest of the Owner

## 29. Prevailing Wage Rates:

- A. Prevailing wage rates shall apply to this contract
- B. The minimum wage rates, health, welfare and pension fund contributions are as determined by the State of Connecticut in accordance with the provisions of Section 31-53/31-54 of the Connecticut General Statutes.
- A. The wages paid on an hourly basis to any person performing the work of any mechanic, laborer or worker on the work herein contracted to be done and the amount of payment or contribution paid or payable on behalf of each such person to any employee welfare fund, as defined in subsection (h) of this section, shall be at a rate equal to the rate customary or prevailing for the same work in the same trade or occupation in the town in which such public works project is being constructed. Any contractor who is not obligated by agreement to make payment or contribution on behalf of such persons to any such employee welfare fund shall pay to each mechanic, laborer or worker as part of such

person's wages the amount of payment or contribution for such person's classification on each pay day.

B. The minimum current wage and benefit rates are set forth in the wage schedule (attached to the Bid Package). The Contractor will be bound and obligated by the Laws of Connecticut to insure payment to all workers involved with construction of this said Project.

C. Certified payroll reports must be submitted to the Town.

### 30. CTDOT Requirements

Following the Bid Opening and announcement of the apparent low bidder, he must submit the completed Pre-Award DBE Commitment Approval Request to the Borough within five (5) days after the Award of the Contract. The document can be found in Section K.

**CTDOT PROJECT #87-146  
RUBBER AVENUE AT HOADLEY STREET AND MELBOURNE STREET  
TRAFFIC SIGNAL REPLACEMENT PROJECT  
Naugatuck, CT**

**SECTION B**

**PROPOSAL**

The undersigned, as Bidder, declares that no person or persons, other than those named herein, are interested in this Proposal; that this Proposal is made without collusion with any person, firm or corporation; that he has carefully examined the location of the proposed work, the proposed Form of Contract, and the Contract Drawings therein referred to; that no person or persons acting in any official capacity for the Owner is directly or indirectly interested therein or in any portion of the profit thereof; and that he proposes and agrees, if this Proposal is accepted, to execute the Form of Contract with the Owner; to provide all necessary equipment, tools, and other means of construction, and to do all work and furnish all materials specified in the Contract, in the manner and time therein prescribed, and according to the requirements of the Borough of Naugatuck Inspector as therein set forth, and that he will take in full payment therefore, the following unit prices and lump sums, to wit:

The Bidder acknowledges receipt of the following addenda:

Addendum No. \_\_\_\_\_ Dated: \_\_\_\_\_

Addendum No. \_\_\_\_\_ Dated: \_\_\_\_\_

The undersigned agrees that he shall execute the Contract within the ten (10) days after the date of award, and shall commence work within the ten (10) days after date of the Notice to Proceed and shall progress therewith to its entire completion within the time stipulated in the Contract.

The Bidder agrees that this bid shall be good and may not be withdrawn for a period of ninety (90) days after the scheduled closing time for receiving bids.

If this Proposal shall be accepted by the Owner and the undersigned shall fail to contract as aforesaid, and to give bonds as required, as determined by the canvass of bids, and with surety or sureties satisfactory to the Owner within ten (10) days from the date of the award, then the Owner may, at its option, determine that the Bidder has abandoned the Contract: thereupon, the Proposal and acceptance shall be null and void, and the bid security, accompanying this Proposal, shall become the property of the said Owner as liquidated damages for the delay and additional expense to the Owner caused thereby if said Proposal shall be rejected, or if said Proposal shall be accepted and the Bidder shall execute and deliver a contract in the Form of Contract attached hereto (properly completed in accordance with said Proposal) and shall furnish a Bond for his faithful performance of said Contract, and for the payment of all persons performing labor or furnishing materials in connection therewith, and shall in all other respects perform the agreement created by the acceptance of said Proposal, the accompanying bid security shall be returned to the undersigned making bid.

**CTDOT PROJECT #87-146**  
**RUBBER AVENUE AT HOADLEY STREET AND MELBOURNE STREET**  
**TRAFFIC SIGNAL REPLACEMENT PROJECT**  
**Naugatuck, CT**  
**PROPOSAL continued**

The undersigned is aware that the Borough of Naugatuck may reject any and all bids in whole or in part; that the Borough may waive technical defects, irregularities and omissions; that the award will be based on the combination of items that will best serve the interest of the Borough; that the bid price does not include any taxes for which the Borough is not liable; and that acceptance of the bid will establish no exclusive contract by which the Borough of Naugatuck will be required to purchase from the undersigned.

The undersigned claims without reservation that his/her bid is made without collusion with any other person, individual or corporation.

Bid Item quantities for unit price bid items are not guaranteed. Final payment will be based on actual installed quantities. Items not specifically identified for payment in the Bid Form shall be assumed to be included in the work effort of other bid items and shall not be paid or requested for payment separately.

Company Name: \_\_\_\_\_

Address: \_\_\_\_\_

Town: \_\_\_\_\_

Telephone: \_\_\_\_\_

Email: \_\_\_\_\_

Agent Name: \_\_\_\_\_

Agent Signature: \_\_\_\_\_

**CTDOT PROJECT #87-146**  
**RUBBER AVENUE AT HOADLEY STREET AND MELBOURNE STREET**  
**TRAFFIC SIGNAL REPLACEMENT PROJECT**  
**Naugatuck, CT**  
**PROPOSAL continued**

**ITEM 0020903A – LEAD COMPLIANCE FOR MISCELLANEOUS EXTERIOR TASKS**

1 L.S. @ \$ \_\_\_\_\_ /L.S. \$ \_\_\_\_\_ Total Price

**ITEM 0201001 – CLEARING AND GRUBBING**

1 L.S. @ \$ \_\_\_\_\_ /L.S. \$ \_\_\_\_\_ Total Price

**ITEM 0202000 – EARTH EXCAVATION**

198 C.Y. @ \$ \_\_\_\_\_ /C.Y. \$ \_\_\_\_\_ Total Price

**ITEM 0202512 – CUT CONCRETE SIDEWALK**

50 L.F. @ \$ \_\_\_\_\_ /L.F. \$ \_\_\_\_\_ Total Price

**ITEM 0202529 – CUT BITUMINOUS CONCRETE PAVEMENT**

1,980 L.F. @ \$ \_\_\_\_\_ /L.F. \$ \_\_\_\_\_ Total Price

**ITEM 0209001 – FORMATION OF SUBGRADE**

286 S.Y. @ \$ \_\_\_\_\_ /S.Y. \$ \_\_\_\_\_ Total Price

**ITEM 0212000 – SUBBASE**

99 C.Y. @ \$ \_\_\_\_\_ /C.Y. \$ \_\_\_\_\_ Total Price

**ITEM 0219001 – SEDIMENTATION CONTROL SYSTEM**

44 L.F. @ \$ \_\_\_\_\_ /L.F. \$ \_\_\_\_\_ Total Price

**ITEM 0219011A – SEDIMENTATION CONTROL SYSTEM AT CATCH BASIN**

14 EA. @ \$ \_\_\_\_\_ /EA. \$ \_\_\_\_\_ Total Price

**CTDOT PROJECT #87-146**  
**RUBBER AVENUE AT HOADLEY STREET AND MELBOURNE STREET**  
**TRAFFIC SIGNAL REPLACEMENT PROJECT**  
**Naugatuck, CT**  
**PROPOSAL continued**

**ITEM 0286001.1 – ROCK IN DRAINAGE  
TRENCH (0’ – 10’ DEEP)**

7 C.Y. @ \$ \_\_\_\_\_ /C.Y. \$ \_\_\_\_\_ Total Price

**ITEM 0404101A – BITUMINOUS CONCRETE  
PATCHING – PARTIAL DEPTH**

5 S.Y. @ \$ \_\_\_\_\_ /S.Y. \$ \_\_\_\_\_ Total Price

**ITEM 0406171 – HMA S0.5”**

385 TON @ \$ \_\_\_\_\_ /TON \$ \_\_\_\_\_ Total Price

**ITEM 0406195A – FILLING JOINTS AND  
CRACKS IN BITUMINOUS CONCRETE  
PAVEMENT**

110 L.F. @ \$ \_\_\_\_\_ /L.F. \$ \_\_\_\_\_ Total Price

**ITEM 0406236 – MATERIAL FOR TACK COAT**

363 GAL @ \$ \_\_\_\_\_ /GAL \$ \_\_\_\_\_ Total Price

**ITEM 0406275A – FINE MILLING OF  
BITUMINOUS CONCRETE (0”-4”)**

2,332 S.Y. @ \$ \_\_\_\_\_ /S.Y. \$ \_\_\_\_\_ Total Price

**ITEM 0520036A – ASPHALIC PLUG EXPANSION  
JOINT SYSTEM**

59 C.F. @ \$ \_\_\_\_\_ /C.F. \$ \_\_\_\_\_ Total Price

**ITEM 0586001.1 – TYPE “C” CATCH BASIN (0’ –  
10’ DEEP)**

1 EA. @ \$ \_\_\_\_\_ /EA. \$ \_\_\_\_\_ Total Price

**CTDOT PROJECT #87-146**  
**RUBBER AVENUE AT HOADLEY STREET AND MELBOURNE STREET**  
**TRAFFIC SIGNAL REPLACEMENT PROJECT**  
**Naugatuck, CT**  
**PROPOSAL continued**

**ITEM 0586002.1 – TYPE “C” CATCH BASIN (4’ SUMP) (0’ – 10’ DEEP)**

1 EA. @ \$ \_\_\_\_\_/EA. \$ \_\_\_\_\_ Total Price

**ITEM 0586013.1 – OFFSET TYPE “C” CATCH BASIN (0’ – 10’ DEEP)**

1 EA. @ \$ \_\_\_\_\_/EA. \$ \_\_\_\_\_ Total Price

**ITEM 0586040.1 – TYPE “C-L” CATCH BASIN (0’ – 10’ DEEP)**

1 EA. @ \$ \_\_\_\_\_/EA. \$ \_\_\_\_\_ Total Price

**ITEM 0586041.1 – TYPE “C-L” CATCH BASIN W/4’ SUMP) (0’ – 10’ DEEP)**

1 EA. @ \$ \_\_\_\_\_/EA. \$ \_\_\_\_\_ Total Price

**ITEM 0586600– RESET CATCH BASIN**

4 EA. @ \$ \_\_\_\_\_/EA. \$ \_\_\_\_\_ Total Price

**ITEM 0586703 – CONVERT TYPE “C-L” CATCH BASIN TO MANHOLE**

1 EA. @ \$ \_\_\_\_\_/EA. \$ \_\_\_\_\_ Total Price

**ITEM 0586750 – TYPE “C” CATCH BASIN TOP**

3 EA. @ \$ \_\_\_\_\_/EA. \$ \_\_\_\_\_ Total Price

**ITEM 0586760 – TYPE “C-L” CATCH BASIN TOP**

1 EA. @ \$ \_\_\_\_\_/EA. \$ \_\_\_\_\_ Total Price

**ITEM 0586780 – MANHOLE FRAME AND COVER**

1 EA. @ \$ \_\_\_\_\_/EA. \$ \_\_\_\_\_ Total Price



**CTDOT PROJECT #87-146**  
**RUBBER AVENUE AT HOADLEY STREET AND MELBOURNE STREET**  
**TRAFFIC SIGNAL REPLACEMENT PROJECT**  
**Naugatuck, CT**  
**PROPOSAL continued**

**ITEM 0601201 – CLASS “F” CONCRETE**

3 C.Y. @ \$ \_\_\_\_\_/C.Y. \$ \_\_\_\_\_ Total Price

**ITEM 0602006 – DEFORMED STEEL BARS – EPOXY COATED**

341 LBS @ \$ \_\_\_\_\_/LBS \$ \_\_\_\_\_ Total Price

**ITEM 0686000.15 – 15” RCP (0’ 10’ DEEP)**

13 L.F. @ \$ \_\_\_\_\_/L.F. \$ \_\_\_\_\_ Total Price

**ITEM 0686000.18 – 18” RCP (0’ 10’ DEEP)**

50 L.F. @ \$ \_\_\_\_\_/L.F. \$ \_\_\_\_\_ Total Price

**ITEM 0686000.24 – 24” RCP (0’ 10’ DEEP)**

3 L.F. @ \$ \_\_\_\_\_/L.F. \$ \_\_\_\_\_ Total Price

**ITEM 0728014A – CRUSHED STONE**

3 C.Y. @ \$ \_\_\_\_\_/C.Y. \$ \_\_\_\_\_ Total Price

**ITEM 0811001 – CONCRETE CURBING**

110 L.F. @ \$ \_\_\_\_\_/L.F. \$ \_\_\_\_\_ Total Price

**ITEM 0905009A – RESET LANDSCAPE WALL**

30 S.F @ \$ \_\_\_\_\_/S.F. \$ \_\_\_\_\_ Total Price

**ITEM 0913000 – REMOVE CHAIN LINK FENCE**

55 L.F. @ \$ \_\_\_\_\_/L.F. \$ \_\_\_\_\_ Total Price

**ITEM 0913021 – 6’ CHAIN LINK FENCE**

55 L.F. @ \$ \_\_\_\_\_/L.F. \$ \_\_\_\_\_ Total Price

**CTDOT PROJECT #87-146**  
**RUBBER AVENUE AT HOADLEY STREET AND MELBOURNE STREET**  
**TRAFFIC SIGNAL REPLACEMENT PROJECT**  
**Naugatuck, CT**  
**PROPOSAL continued**

**ITEM 0921005 – CONCRETE SIDEWALK RAMP**

743 S.F. @ \$ \_\_\_\_\_ /S.F. \$ \_\_\_\_\_ Total Price

**ITEM 0921009A – MONOLITHIC CONCRETE SIDEWALK AND CURB**

3,960 S.F. @ \$ \_\_\_\_\_ /S.F. \$ \_\_\_\_\_ Total Price

**ITEM 0921039 – DETECTABLE WARNING STRIP**

8 EA. @ \$ \_\_\_\_\_ /EA. \$ \_\_\_\_\_ Total Price

**ITEM 0922003A – DECORATIVE BITUMINOUS CONCRETE (PATTERN TYPE)**

1,815 S.F. @ \$ \_\_\_\_\_ /S.F. \$ \_\_\_\_\_ Total Price

**ITEM 0922500 – BITUMINOUS CONCRETE DRIVEWAY (COMMERCIAL)**

495 S.Y. @ \$ \_\_\_\_\_ /S.Y. \$ \_\_\_\_\_ Total Price

**ITEM 0924002 – CONCRETE DRIVEWAY RAMP**

17 C.Y. @ \$ \_\_\_\_\_ /C.Y. \$ \_\_\_\_\_ Total Price

**ITEM 0944000 – FURNISHING AND PLACING TOPSOIL**

47 S.Y. @ \$ \_\_\_\_\_ /S.Y. \$ \_\_\_\_\_ Total Price

**ITEM 0950005 – TURF ESTABLISHMENT**

47 S.Y. @ \$ \_\_\_\_\_ /S.Y. \$ \_\_\_\_\_ Total Price

**ITEM 0950036 – EROSION CONTROL MATTING TYPE E**

35 S.Y. @ \$ \_\_\_\_\_ /S.Y. \$ \_\_\_\_\_ Total Price

**CTDOT PROJECT #87-146**  
**RUBBER AVENUE AT HOADLEY STREET AND MELBOURNE STREET**  
**TRAFFIC SIGNAL REPLACEMENT PROJECT**  
**Naugatuck, CT**  
**PROPOSAL continued**

**ITEM 0969062A – CONSTRUCTION FIELD OFFICE (MEDIUM)**

4 MO. @ \$ \_\_\_\_\_/MO. \$ \_\_\_\_\_ Total Price

**ITEM 0970006 – TRAFFIC PERSON (MUNICIPAL POLICE OFFICER)**

1 EST. @ \$ 79,200 \_\_\_\_\_EST \$ 79,200 \_\_\_\_\_ Total Price

**ITEM 0970007 – TRAFFIC PERSON (UNIFORMED FLAGGER)**

250 HR @ \$ \_\_\_\_\_/HR \$ \_\_\_\_\_ Total Price

**ITEM 0971001A – MAINTENANCE AND PROTECTION OF TRAFFIC**

1 L.S. @ \$ \_\_\_\_\_/L.S. \$ \_\_\_\_\_ Total Price

**ITEM 0974001 – REMOVAL OF EXISTING MASONRY**

22 C.Y. @ \$ \_\_\_\_\_/C.Y. \$ \_\_\_\_\_ Total Price

**ITEM 0975004 – MOBILIZATION AND PROJECT CLOSEOUT**

1 L.S. @ \$ \_\_\_\_\_/L.S. \$ \_\_\_\_\_ Total Price

**ITEM 0977001 – TRAFFIC CONE**

21 EA. @ \$ \_\_\_\_\_/EA. \$ \_\_\_\_\_ Total Price

**ITEM 0980001 – CONSTRUCTION STAKING**

1 L.S. @ \$ \_\_\_\_\_/L.S. \$ \_\_\_\_\_ Total Price

**ITEM 1001001 – TRENCHING AND BACKFILLING**

612 L.F. @ \$ \_\_\_\_\_/L.F. \$ \_\_\_\_\_ Total Price

**CTDOT PROJECT #87-146**  
**RUBBER AVENUE AT HOADLEY STREET AND MELBOURNE STREET**  
**TRAFFIC SIGNAL REPLACEMENT PROJECT**  
**Naugatuck, CT**  
**PROPOSAL continued**

**ITEM 1002015 – ROCK IN FOUNDATION**

10 V.F. @ \$ \_\_\_\_\_ /V.F. \$ \_\_\_\_\_ Total Price

**ITEM 1002201A – TRAFFIC CONTROL  
FOUNDATION – SPAN POLE**

2 EA. @ \$ \_\_\_\_\_ /EA. \$ \_\_\_\_\_ Total Price

**ITEM 1002203 – TRAFFIC CONTROL  
FOUNDATION – PEDESTAL-TYPE I**

5 EA. @ \$ \_\_\_\_\_ /EA. \$ \_\_\_\_\_ Total Price

**ITEM 1002208 – TRAFFIC CONTROL  
FOUNDATON – CONTROLLER – TYPE IV**

1 EA. @ \$ \_\_\_\_\_ /EA. \$ \_\_\_\_\_ Total Price

**ITEM 1008015 – 2” RIGID METAL CONDUIT –  
SURFACE**

66 L.F. @ \$ \_\_\_\_\_ /L.F. \$ \_\_\_\_\_ Total Price

**ITEM 1008115 – 2” RIGID METAL CONDUIT – IN  
TRENCH**

525 L.F. @ \$ \_\_\_\_\_ /L.F. \$ \_\_\_\_\_ Total Price

**ITEM 1008117 – 3” RIGID METAL CONDUIT – IN  
TRENCH**

12 L.F. @ \$ \_\_\_\_\_ /L.F. \$ \_\_\_\_\_ Total Price

**ITEM 1008215 – 2” RIGID METAL CONDUIT –  
UNDER ROADWAY**

110 L.F. @ \$ \_\_\_\_\_ /L.F. \$ \_\_\_\_\_ Total Price

**ITEM 1010001 – CONCRETE HANDHOLE**

3 EA. @ \$ \_\_\_\_\_ /EA. \$ \_\_\_\_\_ Total Price

**CTDOT PROJECT #87-146**  
**RUBBER AVENUE AT HOADLEY STREET AND MELBOURNE STREET**  
**TRAFFIC SIGNAL REPLACEMENT PROJECT**  
**Naugatuck, CT**  
**PROPOSAL continued**

**ITEM 1010021 – CONCRETE HANDHOLE –  
TYPE II**

5 EA. @ \$ \_\_\_\_\_/EA. \$ \_\_\_\_\_ Total Price

**ITEM 1010052 – CONCRETE HANDHOLE CAST  
IRON COVER**

2 EA. @ \$ \_\_\_\_\_/EA. \$ \_\_\_\_\_ Total Price

**ITEM 1010054 – CONCRETE HANDHOLE CAST  
IRON COVER – TYPE II**

3 EA. @ \$ \_\_\_\_\_/EA. \$ \_\_\_\_\_ Total Price

**ITEM 1102002 – 8’ ALUMINUM PEDESTAL**

5 EA. @ \$ \_\_\_\_\_/EA. \$ \_\_\_\_\_ Total Price

**ITEM 1103022A – 30’ STEEL SPAN POLE**

2 EA. @ \$ \_\_\_\_\_/EA. \$ \_\_\_\_\_ Total Price

**ITEM 1105003A – 1 WAY, 3 SECTION SPAN  
WIRE TRAFFIC SIGNAL**

7 EA. @ \$ \_\_\_\_\_/EA. \$ \_\_\_\_\_ Total Price

**ITEM 1105007A – 2 WAY, 3 SECTION SPAN  
WIRE TRAFFIC SIGNAL**

1 EA. @ \$ \_\_\_\_\_/EA. \$ \_\_\_\_\_ Total Price

**ITEM 1105180A – 1 WAY, 1 SECTION BI-  
COLORED ARROW**

2 EA. @ \$ \_\_\_\_\_/EA. \$ \_\_\_\_\_ Total Price

**ITEM 1106001A – 1 WAY PEDESTRIAN SIGNAL  
POLE MOUNTED**

3 EA. @ \$ \_\_\_\_\_/EA. \$ \_\_\_\_\_ Total Price

**CTDOT PROJECT #87-146**  
**RUBBER AVENUE AT HOADLEY STREET AND MELBOURNE STREET**  
**TRAFFIC SIGNAL REPLACEMENT PROJECT**  
**Naugatuck, CT**  
**PROPOSAL continued**

**ITEM 1106003A – 1 WAY PEDESTRIAN SIGNAL  
PEDESTAL MOUNTED**

5 EA. @ \$ \_\_\_\_\_/EA. \$ \_\_\_\_\_ Total Price

**ITEM 1107011A – ACCESSIBLE PEDESTRAIN  
SIGNAL AND DETECTOR (TYPE A)**

8 EA. @ \$ \_\_\_\_\_/EA. \$ \_\_\_\_\_ Total Price

**ITEM 1108115A – FULL ACTUATED  
CONTROLLER 8 PHASE**

1 EA. @ \$ \_\_\_\_\_/EA. \$ \_\_\_\_\_ Total Price

**ITEM 1108724A – PHASE SELECTOR**

1 EA. @ \$ \_\_\_\_\_/EA. \$ \_\_\_\_\_ Total Price

**ITEM 1111201A – TEMPORARY DETECTION  
(SITE 1)**

1 L.S. @ \$ \_\_\_\_\_/L.S. \$ \_\_\_\_\_ Total Price

**ITEM 111401A – LOOP VEHICLE DETECTOR**

5 EA. @ \$ \_\_\_\_\_/EA. \$ \_\_\_\_\_ Total Price

**ITEM 1111451A – LOOP DETECTOR SAWCUT**

340 L.F. @ \$ \_\_\_\_\_/L.F. \$ \_\_\_\_\_ Total Price

**ITEM 1112410A – DETECTOR (TYPE A)**

2 EA. @ \$ \_\_\_\_\_/EA. \$ \_\_\_\_\_ Total Price

**ITEM 1112470A – PRE-EMPTION SYSTEM  
CHASSIS**

1 EA. @ \$ \_\_\_\_\_/EA. \$ \_\_\_\_\_ Total Price

**CTDOT PROJECT #87-146**  
**RUBBER AVENUE AT HOADLEY STREET AND MELBOURNE STREET**  
**TRAFFIC SIGNAL REPLACEMENT PROJECT**  
**Naugatuck, CT**  
**PROPOSAL continued**

**ITEM 1113004 – 2 CONDUCTOR NO. 8 CABLE**

60 L.F. @ \$ \_\_\_\_\_/L.F. \$ \_\_\_\_\_ Total Price

**ITEM 1113050 – 2 CONDUCTOR NO. 14 CABLE**

1,210 L.F. @ \$ \_\_\_\_\_/L.F. \$ \_\_\_\_\_ Total Price

**ITEM 1113102 – 5 CONDUCTOR NO. 14 CABLE**

825 L.F. @ \$ \_\_\_\_\_/L.F. \$ \_\_\_\_\_ Total Price

**ITEM 1113103 – 7 CONDUCTOR NO. 14 CABLE**

1,601 L.F. @ \$ \_\_\_\_\_/L.F. \$ \_\_\_\_\_ Total Price

**ITEM 1113104 – 9 CONDUCTOR NO. 14 CABLE**

248 L.F. @ \$ \_\_\_\_\_/L.F. \$ \_\_\_\_\_ Total Price

**ITEM 1113109 – 21 CONDUCTOR NO. 14 CABLE**

154 L.F. @ \$ \_\_\_\_\_/L.F. \$ \_\_\_\_\_ Total Price

**ITEM 1113399 – CABLE CLOSURE**

2 EA. @ \$ \_\_\_\_\_/EA. \$ \_\_\_\_\_ Total Price

**ITEM 1113550A – DETECTOR CABLE  
(OPTICAL)**

330 L.F. @ \$ \_\_\_\_\_/L.F. \$ \_\_\_\_\_ Total Price

**ITEM 1114102 – SPAN WIRE**

300 L.F. @ \$ \_\_\_\_\_/L.F. \$ \_\_\_\_\_ Total Price

**CTDOT PROJECT #87-146**  
**RUBBER AVENUE AT HOADLEY STREET AND MELBOURNE STREET**  
**TRAFFIC SIGNAL REPLACEMENT PROJECT**  
**Naugatuck, CT**  
**PROPOSAL continued**

**ITEM 1118012A - REMOVAL AND/OR  
RELOCATION OF TRAFFIC SIGNAL  
EQUIPMENT (SITE 1)**

1 L.S. @ \$ \_\_\_\_\_ /L.S. \$ \_\_\_\_\_ Total Price

**ITEM 1118051A - TEMPORARY  
SIGNALIZATION (SITE 1)**

1 L.S. @ \$ \_\_\_\_\_ /L.S. \$ \_\_\_\_\_ Total Price

**ITEM 1206023A - REMOVAL AND  
RELOCATION OF EXISTING SIGNS**

1 L.S. @ \$ \_\_\_\_\_ /L.S. \$ \_\_\_\_\_ Total Price

**ITEM 1208932A - SIGN FACE-SHEET  
ALUMINUM (TYPE IV RETROREFLECTIVE  
SHEETING)**

31 S.F. @ \$ \_\_\_\_\_ /S.F. \$ \_\_\_\_\_ Total Price

**ITEM 1210101 - 4" WHITE EPOXY RESIN  
PAVEMENT MARKINGS**

264 L.F. @ \$ \_\_\_\_\_ /L.F. \$ \_\_\_\_\_ Total Price

**ITEM 1210102 - 4" YELLOW EPOXY RESIN  
PAVEMENT MARKINGS**

939 L.F. @ \$ \_\_\_\_\_ /L.F. \$ \_\_\_\_\_ Total Price

**ITEM 1210105 - EPOXY RESIN PAVEMENT  
MARKINGS, SYMBOLS AND LEGENDS**

651 S.F. @ \$ \_\_\_\_\_ /S.F. \$ \_\_\_\_\_ Total Price

**ITEM 1220027 - CONSTRUCTION SIGNS**

198 S.F. @ \$ \_\_\_\_\_ /S.F. \$ \_\_\_\_\_ Total Price



**CTDOT PROJECT #87-146**  
**RUBBER AVENUE AT HOADLEY STREET AND MELBOURNE STREET**  
**TRAFFIC SIGNAL REPLACEMENT PROJECT**  
**Naugatuck, CT**  
**PROPOSAL continued**

**ITEM 1302047A – RESET GATE BOX**

5 EA. @ \$ \_\_\_\_\_/EA. \$ \_\_\_\_\_ Total Price

**ITEM 1403501A – RESET MANHOLE  
(SANITARY SEWER)**

3 EA. @ \$ \_\_\_\_\_/EA. \$ \_\_\_\_\_ Total Price

**ITEM 1507000A – PROTECTION AND SUPPORT  
OF EXISTING UTILITIES**

1 L.S. @ \$ \_\_\_\_\_/L.S. \$ \_\_\_\_\_ Total Price

Total Bid Amount \$ \_\_\_\_\_

**CTDOT PROJECT #87-146**  
**RUBBER AVENUE AT HOADLEY STREET AND MELBOURNE STREET**  
**TRAFFIC SIGNAL REPLACEMENT PROJECT**  
**Naugatuck, CT**  
**PROPOSAL continued**

SECTION C

**REFERENCES/QUALIFICATIONS**

The Bidder is required to fill out the following form to enable the Owner to make inquiries and judge as to the Bidder's experience, skill, available financial resources, credit, and business standing.

1. Number of years the bidder has been in business as a General Contractor: \_\_\_\_\_

2. Has the Bidder ever failed complete work awarded; and if so, state where and why:

\_\_\_\_\_

\_\_\_\_\_

\_\_\_\_\_

3. Does the Bidder plan to sublet any part of this work; and if so, give details:

\_\_\_\_\_

\_\_\_\_\_

4. List equipment Bidder owns that is available for this project:

\_\_\_\_\_

\_\_\_\_\_

\_\_\_\_\_

\_\_\_\_\_

5. List equipment the Bidder plans to rent or purchase for this project:

\_\_\_\_\_

\_\_\_\_\_

\_\_\_\_\_

Major Material Supplier: \_\_\_\_\_

\_\_\_\_\_  
Bidder

**CTDOT PROJECT #87-146**  
**RUBBER AVENUE AT HOADLEY STREET AND MELBOURNE STREET**  
**TRAFFIC SIGNAL REPLACEMENT PROJECT**  
**Naugatuck, CT**  
**PROPOSAL continued**

<b>BOROUGH OF NAUGATUCK</b>
-----------------------------

**CONTRACTOR’S QUALIFICATION SUMMARY**

The bidder is required to submit this summary with his bid in order that the Borough of Naugatuck may properly evaluate the qualifications of the Contractor. Failure to submit this summary in proper form will be cause of rejection of the bid. .

List projects below:

<b>Owner’s Name</b>	<b>Year Completed</b>	<b>Project Number</b>	<b>Tons Disposed</b>	<b>Person to Contact Name/Telephone</b>

**VENDOR NAME: \_\_\_\_\_**

**CTDOT PROJECT #87-146**  
**RUBBER AVENUE AT HOADLEY STREET AND MELBOURNE STREET**  
**TRAFFIC SIGNAL REPLACEMENT PROJECT**  
**Naugatuck, CT**  
**PROPOSAL continued**

**SECTION D**

**BID BOND /SURETY GUARANTY**

**CTDOT PROJECT #87-146**  
**RUBBER AVENUE AT HOADLEY STREET AND MELBOURNE STREET**  
**TRAFFIC SIGNAL REPLACEMENT PROJECT**

**Naugatuck, CT**  
**PROPOSAL continued**

**BID BOND**

KNOW ALL MEN BY THESE PRESENTS, that we the undersigned:

as Principal, and \_\_\_\_\_ as Surety are held and firmly bound unto Borough of Naugatuck hereinafter called the "Owner", in the penal sum of \_\_\_\_\_ Dollars, (\$ \_\_\_\_\_) lawful money of the United States, for the payment of which sum well and truly to be made, we bind ourselves, our heirs, executors, administrators, successors, and assigns, jointly and severally, firmly by these presents.

THE CONDITIONS OF THIS OBLIGATION IS SUCH, that whereas the Principal has submitted the accompanying BID, dated \_\_\_\_\_, 20\_\_\_\_, for \_\_\_\_\_

\_\_\_\_\_  
NOW THEREFORE, if the Principal shall not withdraw said Bid within the time period specified therein after the opening of the same, or within any extended time period agreed to by the Principal, Surety and Owner, or, if no period be specified, within ninety (90) days after the said opening, and shall within the period specified thereof, or if no period be specified, within twenty (20) days after the prescribed forms are presented to him for signature, enter into a written Contract with the Owner in accordance with the Bid as accepted, and give bond with good and sufficient surety or sureties, as may be required, for the faithful performance and proper fulfillment of such Contract; then the above obligation shall be null and void and of no effect, otherwise to remain in full force or virtue.

Failure to comply with the aforementioned condition shall result in the forfeiture of this BID BOND as liquidated damages.

IN WITNESS WHEREOF, the above-bounded parties have executed this Instrument under their several seals this \_\_\_\_\_ day of \_\_\_\_\_, 20\_\_\_\_, the name and corporate seal of each corporate party being hereto affixed and these presents signed by its undersigned representative, pursuant to authority of its governing body.

No extension of time or other modification of the BID BOND shall be valid unless agreed to in writing by the parties to this Bond.

**CTDOT PROJECT #87-146**  
**RUBBER AVENUE AT HOADLEY STREET AND MELBOURNE STREET**  
**TRAFFIC SIGNAL REPLACEMENT PROJECT**  
**Naugatuck, CT**  
**PROPOSAL continued**

**BID BOND**  
(Page 2 of 2)

In presence of:

\_\_\_\_\_ (Individual Principal)

\_\_\_\_\_ (Business Address)

\_\_\_\_\_ (Individual Principal)

\_\_\_\_\_ (Business Address)

Attest:

\_\_\_\_\_ (Corporate Principal)

\_\_\_\_\_ (Business Address)

By: \_\_\_\_\_ Affix  
Corporate Seal

Attest:

\_\_\_\_\_ (Corporate Surety)

\_\_\_\_\_ (Business Address)

By: \_\_\_\_\_ Affix  
Corporate Seal

Countersigned

By: \_\_\_\_\_

\* Attorney-in Fact, State of \_\_\_\_\_

\* Power-of Attorney for person signing for Surety Company must be attached to Bond.

**CTDOT PROJECT #87-146**  
**RUBBER AVENUE AT HOADLEY STREET AND MELBOURNE STREET**  
**TRAFFIC SIGNAL REPLACEMENT PROJECT**  
**Naugatuck, CT**  
**PROPOSAL continued**

**SURETY GUARANTY FORM**

(To accompany Proposal)

KNOW ALL MEN BY THESE PRESENTS, that for and in consideration of the sum of \$1.00, lawful money of the United States, the receipt whereof is hereby acknowledged, paid the undersigned corporation, and for other valuable consideration, the

\_\_\_\_\_ a corporation organized and existing under

(Name of Surety Company)

laws of the State of \_\_\_\_\_ and licensed to do business in the State of Connecticut, certifies and agrees, that if the Contract for the Disposal of Controlled Materials is awarded to \_\_\_\_\_ the undersigned corporation

(Name of Bidder)

will execute the bond or bonds as required by the Contract Documents and will become Surety in the full amount of the Contract Price for the faithful performance of the Contract and for payment of all persons supplying labor or furnishing materials in connection therewith.

\_\_\_\_\_  
(Surety)

(To be accompanied by the usual proof of authority of officers of Surety Company to execute the same.)

**CTDOT PROJECT #87-146**  
**RUBBER AVENUE AT HOADLEY STREET AND MELBOURNE STREET**  
**TRAFFIC SIGNAL REPLACEMENT PROJECT**  
**Naugatuck, CT**  
**PROPOSAL continued**

**SECTION E**

**CONTRACT AGREEMENT AND  
CERTIFICATE AS TO CORPORATE PRINCIPAL**



**CTDOT PROJECT #87-146**  
**RUBBER AVENUE AT HOADLEY STREET AND MELBOURNE STREET**  
**TRAFFIC SIGNAL REPLACEMENT PROJECT**  
**Naugatuck, CT**  
**PROPOSAL continued**

**CONTRACT AND AGREEMENT**

THIS AGREEMENT, made this \_\_\_\_\_ day of \_\_\_\_\_ in the year 20 \_\_\_\_,  
Between the Borough of Naugatuck, with its principal office and place of business at 229 Church  
Street, Connecticut 06770, acting herein through it's Mayor and  
\_\_\_\_\_, a \_\_\_\_\_, with an office and  
place of business at \_\_\_\_\_, hereinafter called the contractor.

WITNESSETH: That the parties to this agreement in consideration of the undertakings, promises,  
and agreements on the part of the other herein contained, hereby undertake, promise, and agree as  
follows:

**I Definitions**

The word "Owner" as used herein shall mean the Borough of Naugatuck, acting through  
its properly authorized representatives.

The words "as directed", "as required", "as permitted", "as allowed", or phrases of like  
effect or import, used herein shall mean that the direction, requirement, permission, or allowance  
of the Borough of Naugatuck Inspector is intended and similarly the words "approved",  
"reasonable", "suitable", "proper", "satisfactory", or words of like effect or import, unless  
otherwise particular specified herein, shall mean approved, reasonable, suitable, proper, or  
satisfactory in the judgement of the Borough of Naugatuck Inspector.

The word "Contractor" shall mean \_\_\_\_\_ or it's duly authorized agents.

**II Contract Includes**

The indices, headings and subheadings are for convenience only and do not form a part of  
the Contract Documents.

The Contractor shall, at his own sole cost and expense, furnish all labor, materials, and  
other services necessary for the completion of this Contract and shall complete and finish the same  
in the most thorough, workmanlike, and substantial manner, in every respect, to the satisfaction  
and approval of the Borough of Naugatuck Inspector, in the manner and within the time hereinafter  
limited, and in strict accordance with the Advertisement, Information for Bidders, Proposal,  
General Requirements, Detailed Specifications, and Addenda hereto attached, and the Contract  
Drawings herein referred to, (collectively the "contract documents"), which contract documents  
are hereby made a part of this Contract as fully as if the same were repeated at length herein.

Addendum No. ____	Dated: _____	Addendum No. ____	Dated: _____
Addendum No. ____	Dated: _____	Addendum No. ____	Dated: _____
Addendum No. ____	Dated: _____	Addendum No. ____	Dated: _____

**CTDOT PROJECT #87-146**  
**RUBBER AVENUE AT HOADLEY STREET AND MELBOURNE STREET**  
**TRAFFIC SIGNAL REPLACEMENT PROJECT**  
**Naugatuck, CT**  
**PROPOSAL continued**

III Specifications and Contract Drawings Supplementary

The said Specifications and Contract Drawings are intended to supplement each other, and together constitute one complete set of Specifications and Contract Drawings, so that any work exhibited in the one and not in the other shall be executed just as if it had been set forth in both, in order that the work shall be completed in every respect according to the complete design or designs as decided and determined by the Borough of Naugatuck Inspector. Should anything be omitted from the Specifications and Contract Drawings, the Contractor shall promptly notify the Borough of Naugatuck Inspector. From time to time during the progress of the work, the Borough of Naugatuck Inspector will furnish such supplementary or working drawings as are necessary to show changes or define the work in more detail, and these also shall be considered as Contract Drawings. When discrepancies exist between the Contract Drawings and Specifications, the Specifications shall govern.

IV Modifications

The Contractor, in entering into this Contract, understands that the Owner reserves the right to modify, to the extent herein provided, the arrangement, character, grade, or size of the work or appurtenances whenever, in the Owner's opinion, it shall be deemed necessary or advisable to do so. Minor changes in the work, not involving extra cost and consistent with the purposes of the work, may be made by verbal order, but no modifications involving extra work or material changes shall be made unless ordered in writing by the Borough of Naugatuck Inspector; and if the modification requires additional cost, a purchase order must be issued prior to work commencing. The Contractor shall and will accept such modifications when ordered in writing by the Owner through the Borough of Naugatuck Inspector, and the same shall not vitiate or void this Contract.

Any such modifications so made shall not, however, subject the Contractor to increased expense without equitable compensation, which shall be determined by the Borough of Naugatuck Inspector. If such modifications result in a decrease in the cost of work involved, and equitable deduction from the Contract price, to be determined by the Borough of Naugatuck Inspector, shall be made. The Borough of Naugatuck Inspector's determination of such additional compensation, or of any such deduction, shall be based upon the unit prices in the Contractor's bid, unless the modification involves work not included in such bids and then in the event, the modification shall be as set forth in Section XXVIII prior to the commencement of additional work. In no event shall any modification in the work shown on the Plans and Specifications be made unless the nature and extent thereof has first been certified by the Borough of Naugatuck Inspector in writing and sent to the Contractor.

V Correction of Errors and Omissions

The Plans and Specifications forming part of this Contract are intended to be explanatory of each other, but should any discrepancy appear, or misunderstanding arise, as to the import of anything contained in either, the explanation and decision of the Borough of Naugatuck Inspector shall be final and binding on the Contractor; and all directions and explanations required, to complete and make effective any of the provisions of the Contract and Specifications, shall be given by the Borough of Naugatuck Inspector. Corrections of errors and omissions in the Drawings or Specifications may be made by the Borough of Naugatuck Inspector when such corrections are necessary for the proper fulfillment of the Contract Documents as construed by the Borough of Naugatuck Inspector. The effect of such corrections shall date from the time that the Borough of Naugatuck Inspector gives due notice thereof to the Contractor.

**CTDOT PROJECT #87-146**  
**RUBBER AVENUE AT HOADLEY STREET AND MELBOURNE STREET**  
**TRAFFIC SIGNAL REPLACEMENT PROJECT**  
**Naugatuck, CT**  
**PROPOSAL continued**

VI Borough of Naugatuck Inspector's Decision

All work under this Contract shall be done to the satisfaction of the Borough of Naugatuck Inspector, who shall determine the amount, quality, acceptability, and fitness of the several items of work and materials which are to be paid for hereunder. He also shall decide all questions which may arise as to the fulfillment of the terms of the Contract, Plans and Specifications. The determination of the Borough of Naugatuck Inspector in all such matters shall be final and binding upon the parties thereto.

VII Inspection of Work

It is agreed that the Owner may, at its pleasure, appoint and employ, at its own expense, such persons as may be necessary, who are to act as Borough of Naugatuck Inspectors, inspections, or agents, for the purpose of determining, in the Borough's interest, that the materials furnished and the work done, as the work progresses, conforms to the requirements of the Contract Documents. Such persons shall have unrestricted access to all parts of the work and to other places at and where the preparation of the materials and other parts of the work to be done under this Contract are carried on and conducted. They shall be given, by the Contractor, all facilities and assistance required to carry out their work of inspection.

It is not the function of the Borough of Naugatuck Inspector to supervise or direct the manner in which the work to be done under this Contract is carried on or conducted. The Borough of Naugatuck Inspector is not responsible for construction means, methods, techniques, sequences, or procedures, or for safety precautions and programs in connection with the work, and he will not be responsible for the Contractor's failure to carry out the work in accordance with the Contract Documents.

The Borough of Naugatuck Inspector shall have authority to reject and shall reject any work or material, or any part thereof, which does not, in his opinion, conform to the Contract Drawings, working drawings, Specifications, and Contract, and it shall be permissible for him to do so at any time during the progress of the work.

No work shall be done except in the presence of the Borough of Naugatuck Inspector or his assistants. No material of any kind shall be used upon the work until it has been inspected and accepted by the Borough of Naugatuck Inspector. Any materials or workmanship found at any time to be defective, or not of the quality or character required by the Contract Drawings and Specifications, shall be remedied at once regardless of previous inspection.

Such inspection shall not relieve the Contractor from any obligation to perform said work strictly in accordance with the Contract Drawings and Specifications, and work not so constructed shall be removed and made good by the Contractor at this own expense and free of all expense to the Owner, whenever so ordered by the Owner, without reference to any previous oversight or error in inspection.

VIII Address of Contractor

The address in the Proposal, upon which this Contract is based, shall be the place. The delivering at the above-named place of any such notice, letter, or other communication where notices, letters or other communications to the Contractor may be mailed or delivered, from the Borough to the Contractor, the date of said service shall be the date of such delivery. Nothing herein contained shall be deemed to preclude or render inoperative the service of any notice, letter, or other communication upon the Contractor personally.

**CTDOT PROJECT #87-146**  
**RUBBER AVENUE AT HOADLEY STREET AND MELBOURNE STREET**  
**TRAFFIC SIGNAL REPLACEMENT PROJECT**  
**Naugatuck, CT**  
**PROPOSAL continued**

**IX Obligation of the Contractor**

The Contractor shall, at his own expense, provide any and all manner of supervisor, insurance, taxes, labor, materials, apparatus, scaffolding, appliances, tools, machinery, power, transportation, and whatever else may be required of every description necessary to do and complete the work and shall be solely answerable for the same and for the safe, proper, and lawful construction, maintenance, and use thereof. The Contractor shall cover and protect the work from damage and shall make good all injury to the same occurring before completion of this Contract. The Contractor shall employ only competent workmen and shall provide experienced superintendents and foremen on each part of the work.

The Contractor shall, at its own expense, wherever necessary or required, maintain fences, provide watchmen, maintain lights, place additional timber and braces, and take such other precautions as may be necessary to protect life, property, and structures, vehicles and pedestrians and shall be liable for all damages, occasioned in any way by his act or neglect or that of this agent, employees, or workmen. He shall provide access at all times to private property.

**X Occupational Safety and Health Act**

The applicable sections of the Occupational Safety and Health Act of 1970 (Williams-Steiger Act) shall apply and be made a part of this Contract. The Contractor's attention is particularly directed to the record keeping requirements of this Act.

**XI Nondiscrimination in Employment**

The Contractor agrees and warrants that, in the performance of this Contract, he will not discriminate or permit discrimination against any person or group of persons on the grounds of race, color, sex, religion, or national origin in any manner prohibited by State, Federal, County or Municipal law.

**XII Personal Attention and Competent Workmen**

The Contractor shall give his personal attention constantly to the faithful prosecution of the work and shall be present, either in person or by a duly authorized representative, on the site of the work continually during its progress to receive directions or instructions from the Borough of Naugatuck Inspector. The Contractor shall employ at the site, during the performance of the work, a competent superintendent or foreman who shall be satisfactory to the Borough of Naugatuck Inspector and who shall not be changed, except with the consent of the Borough of Naugatuck Inspector, unless he shall cease to be an employee of the Contractor. Such superintendent or foreman shall represent and have full authority to act for the Contractor in his absence, and all directions and instructions given such superintendent or foreman shall be as binding as if given to the Contractor.

The Contractor shall employ only competent, skillful men to do the work, and whenever the Borough of Naugatuck Inspector shall notify the Contractor in writing that any man on the work is, in his opinion, incompetent, unfaithful, disorderly, or otherwise unsatisfactory, such man shall be discharged from the work and shall not again be employed on it, except with the consent of the Borough of Naugatuck Inspector.

**XIII Public Safeguards**

The Contractor agrees to conduct the work at all times in such a manner that public travel shall not be inconvenienced needlessly nor shall it be wholly obstructed at any point.

**CTDOT PROJECT #87-146**  
**RUBBER AVENUE AT HOADLEY STREET AND MELBOURNE STREET**  
**TRAFFIC SIGNAL REPLACEMENT PROJECT**  
**Naugatuck, CT**  
**PROPOSAL continued**

**XIV Materials and Workmanship**

It is the intent of the Specifications to describe fully and definitely the character of materials and workmanship furnished regarding all ordinary features and to require first-class work and materials in all particulars. For any unexpected features arising during the progress of the work and not fully covered herein, the Specifications shall be interpreted by the Borough of Naugatuck Inspector to require first class work and materials in all respects, and such interpretation shall be accepted by the Contractor.

**XV Materials and Manufactured Articles**

All materials and workmanship shall be subject to the approval of the Borough of Naugatuck Inspector and shall be in conformity with approved modern practice.

Unless otherwise specifically provided for in the Specifications, all materials incorporated in the work shall be new, of standard and first-class quality, and of the best workmanship and design. No inferior, or low grade, material will be either approved or accepted, and all work of assembly and construction must be done in a neat, first-class, and workmanlike manner.

**XVI Unnoticed Defects**

The inspection of the work and materials by the Borough of Naugatuck Inspector shall not relieve the Contractor of any of his obligations to fulfill this Contract, as herein described, and defective work shall be made good and unsuitable materials shall be rejected, notwithstanding that such work and materials had been previously overlooked by the Borough of Naugatuck Inspector and accepted or estimated for payment. If the work, or any part thereof, shall be found defective at any time before final acceptance of the whole work, the Contractor shall forthwith make good such defects, in a manner satisfactory to the Borough of Naugatuck Inspector.

**XVII Care and Protection of Work**

From the commencement of the work until the completion of the same, the Contractor shall be solely responsible for the care of the work covered by the Contract and for the materials delivered at the site intended to be used in the work; and all injury, damage, or loss of the same, from whatever cause, shall be made good at his expense before the final estimate is made. He shall provide suitable means of protection for all materials intended to be used in the work and for all work in progress as well as for completed work. He shall take all necessary precautions to prevent injury or damage to the work under construction by flood, freezing or inclement weather at any and all times. The methods used for this purpose shall be subject to the approval of the Borough of Naugatuck Inspector, but shall not relieve the Contractor from liability for inadequate protection of the work or materials.

**XVIII Assignment of Contract**

The Contractor shall have no right or power to assign this Contract, in whole or in part, nor to assign any right arising, or moneys due or to grow due thereunder, without prior written approval of the Owner.

**XIX Subcontracting**

The Contractor may utilize the services of specialty subcontractors on those parts of the work which, under normal contracting practices, are performed by specialty subcontractors. The Contractor shall not award the work to a subcontractor(s) without prior written approval of the Owner. The Contractor shall be fully responsible to the Owner for the acts and omissions of his subcontractors, and of persons either directly or indirectly employed by them, as he is for the acts

**CTDOT PROJECT #87-146**  
**RUBBER AVENUE AT HOADLEY STREET AND MELBOURNE STREET**  
**TRAFFIC SIGNAL REPLACEMENT PROJECT**  
**Naugatuck, CT**  
**PROPOSAL continued**

and omissions of persons directly employed by him.

The Contractor shall cause appropriate provisions to be inserted in all subcontracts relative to the work to bind subcontractors to the Contractor by the terms of these Contract Documents, insofar as applicable to the work of subcontractors, and to give the Contractor the same power as regards terminating any subcontract that the Owner may exercise over the Contractor under any provisions of these Contract Documents.

Nothing contained in this contract shall create any contractual relation between any subcontractor and the Owner.

**XX Liability of Contractor for Employees**

Each and every employee of the Contractor and each and every of his subcontractors engaged in the said work shall, for all purposes, be deemed and taken to be the exclusive servants of the Contractor and not for any purpose or in any manner in the employment of the Owner. The Contractor shall, in no manner, be relieved from responsibility or liability on account of any fault or delay in the execution of the said work, or any part thereof, by any such employee, or any such subcontractor, or any material men, whatsoever.

**XXI Coordination With Other Contractors and Utilities**

During the progress of the work, existing utilities may be found to be in close proximity to or in conflict with the work being installed. The Contractor shall make every effort to identify and locate these utilities before working in the area. If it is known or found that these utilities exist the Contractor shall contact the appropriate utility and alert them to the situation. Should an existing utility be found to be in close proximity to the work the Contractor shall take all the necessary precautions to protect the utilities and his work. Should existing utilities be found to conflict with the work the Contractor shall arrange with the utility company for their adjustment. No additional compensation will be made for delays, inconvenience or damage sustained by the Contractor due to interference from the above-noted utility appurtenances or the operation of locating, installing or moving them or the inability of others to perform their work in a timely manner.

**XXII Permits, Laws, Codes, Ordinances and Insurance**

The Contractor shall keep himself fully informed of all existing and current codes, ordinances, and regulations and Municipal, County, State or National laws in any way limiting or controlling the actions or operations of those engaged upon the work or affecting the materials supplied to or by them. He shall, at all times, observe and comply with all such valid and legally binding ordinances, laws, and regulations and shall protect and indemnify the Owner and its representatives and agents against any claim or liability arising from, or based on, any violation of the same. He shall obtain and pay for all necessary permits and pay all fees required in connection with the Contract. Contractor shall provide the types and amounts of insurance as set forth in Section 19, Information of Bidders and maintain in effect. He shall take out and carry appropriate employer's liability insurance and public liability insurance.

**XXIII Patent Rights**

The Contractor shall indemnify and save harmless the Owner and its officers, agents, and representatives from all claims for damages arising from the infringements, or alleged infringements, of any Letters Patent or patent rights covering any material, appliance, or device used in or upon the work or any part thereof.

All royalties for patents or patent infringement claims, that might be involved in the construction or use of the work, shall be included in the Contract amount; and the Contractor shall satisfy all demands that may be made at any time for such and shall be liable for any damage or

**CTDOT PROJECT #87-146**  
**RUBBER AVENUE AT HOADLEY STREET AND MELBOURNE STREET**  
**TRAFFIC SIGNAL REPLACEMENT PROJECT**  
**Naugatuck, CT**  
**PROPOSAL continued**

claims for patent infringements; and the Contractor shall, at his own expense, defend any and all suits or proceedings that may be instituted against the Owner for infringement, or alleged infringement, of any patent or patents involved, or alleged to be involved, in the work; and in case of any award for damages, the said Contractor shall pay such award.

**XXIV Defense of Suits**

The Contractor shall indemnify and hold harmless the Borough of Naugatuck and the State of Connecticut and its consultants, agents and employees from and against all claims, damages, losses, and expenses, including, but not limited to, attorney fees, ("indemnification expense") arising out of or resulting from the performance of the work or arising out of or resulting from the Contract Documents, including, without limitation, all indemnification expense regarding personal injury or death and/or damage to real or personal property or motor vehicles.

In claims against any person or entity indemnified under this section by an employee or the Contractor, a Subcontractor, anyone directly or indirectly employed by them or anyone for whose acts they may be liable, the indemnification obligation under this Section shall not be limited by a limitation on amount or type of damages, compensation or benefits payable by or for the Contractor or a Subcontractor under worker's or workmen's compensation acts, disability benefit acts or other employee benefit acts.

**XXV Claims for Labor and Materials**

The Contractor shall indemnify and save harmless the Owner from all claims expenses and for judgments regarding labor done or materials furnished under this Contract, or any alterations or modifications thereof, including without limitation, reasonable Attorney's fees. Contractor shall furnish the Owner with a Mechanic's Lien Waiver from all persons who have done work, or furnished materials under this Contract. In case such waiver is not furnished, an amount necessary or sufficient, within the discretion of the Owner, to meet the claims of the persons aforesaid, shall be retained, as herein specified, from the money due the Contractor under this Contract until the liabilities aforesaid shall be fully discharged or satisfactorily secured.

**XXVI Completion of Work by Owner**

If the work to be done under this Contract shall be abandoned by the Contractor; or if this Contract shall be assigned, or the work sublet by him, otherwise than as herein specified; or if at any time the Owner shall be of the opinion that the performance of the Contract is unnecessarily or unreasonably delayed; or if the Contractor is willfully violating any of the conditions or covenants of this Contract, or of the Specifications, or is executing the same in bad faith or not in accordance with the terms thereof; or if the work be not fully completed within the time named in this Contract for its completion, or within the time to which the completion of the Contract may be extended by the Owner, the Owner may notify the Contractor to discontinue all work, or any part thereof under his Contract, by a written notice to be served upon the Contractor as herein provided.

The Contractor shall, within five (5) days of the service of said written notice, discontinue the work, or such part thereof, and the Owner shall thereupon have the power to contract for the completion of the Contract, in the manner prescribed by law; or to place such and so many persons as it may be deemed advisable, by contract or otherwise, to work, and complete the work herein described, or such part thereof; or to take possession of and use any of the materials, plant, tools, equipment, supplies, and property of every kind provided by the Contractor for the purpose of his work; and to procure other materials and equipment for the completion of the same; and to charge the expense of said labor, materials and equipment to the Contractor.

**CTDOT PROJECT #87-146**  
**RUBBER AVENUE AT HOADLEY STREET AND MELBOURNE STREET**  
**TRAFFIC SIGNAL REPLACEMENT PROJECT**  
**Naugatuck, CT**  
**PROPOSAL continued**

The expense so charged shall be deducted and paid by the Owner out of such moneys as may be due, or may at any time thereafter grow due to the Contractor under and by virtue of this Contract, or any art thereof; and in case such expense shall exceed the amount which would have

**XXVI Completion of Work by Owner (continued)**

been payable under the Contract, if the same had been completed by the Contractor, the Contractor or his surety shall pay the amount of such excess to the Owner within five (5) days of written demand therefore; and in case such expense shall be less than the amount which would have been payable under this Contract, if the same had been completed by the Contractor, the owner shall pay such difference to the Contractor within five (5) days of written demand.

**XXVII Partial and Final Estimates**

On, or about, the last day of the month, the Borough of Naugatuck Inspector shall make an approximate estimate of the value of the work done and of the materials incorporated into the work.

The Owner will pay the Contractor, within 30 days of receipt of an estimate, the Owner will pay based on the specifications shown in Section 1.09.06 and 9.75 of the CTDOT Form 817.

The Borough of Naugatuck Inspector shall, as soon as practicable after the completion of work, make a final certificate of the entire amount of the work done under this Contract, and the value thereof, and the Owner shall, within thirty (30) days after such final estimate is approved, pay the entire sum so found to be due hereunder, after deducting there from all previous payments and also all percentages and deductions to be retained under any of the provisions of this Contract.

Before payment of each estimate, the Contractor shall provide the Owner with a mechanic's lien waiver from the Contractor and all persons who have done work or furnished materials under this Contract.

**XXVIII Extra Work**

The Contractor shall and will do any and all work and furnish any and all materials not herein provided for which, in the opinion of the Borough of Naugatuck Inspector, may be found necessary or advisable for the proper completion of the work or the purposes thereof, or any modifications or alternations thereto.

All extra work and materials shall be ordered in writing by the Borough of Naugatuck Inspector, and in no case will any work or materials in excess of the amount shown in the Plans and Specifications be paid for unless so ordered. Additionally, if the extra work requires additional cost, a purchase order must be issued prior to work commencing. No claim for delay shall be made as a result of this process. No voucher, claim or charge against the Borough shall be paid, nor is the Borough liable for any voucher, claim or charge unless a purchase order is issued. The Contractor further agrees that he shall accept, as full compensation for such extra work and materials, the unit price bid, in the case of Items covered by unit prices in the Proposal, and no more; and for such Items as are not covered by a unit price, he shall accept as full compensation:

1. An agreed on lump sum price, or
2. The reasonable cost, as determined by the Borough of Naugatuck Inspector, of all necessary labor, including insurance and payroll taxes, equipment rental, and materials, plus fifteen percent (15%) which covers supervision, the use of tools and plant, and other overhead expenses and profit.



**CTDOT PROJECT #87-146**  
**RUBBER AVENUE AT HOADLEY STREET AND MELBOURNE STREET**  
**TRAFFIC SIGNAL REPLACEMENT PROJECT**  
**Naugatuck, CT**  
**PROPOSAL continued**

The equipment rental charge shall be at prevailing rates usually paid locally but shall in no case exceed the amount prorated on the basis of the monthly equipment rental rates compiled by the Associated Equipment Distributors.

When extra work is performed by an approved subcontractor, the Contractor shall be entitled to five percent (5%) of the direct cost of the subcontractor's work to cover his overhead expenses and profit.

The Contractor agrees to prosecute such extra work with all reasonable diligence and to employ thereon competent men. The Contractor shall give the Borough of Naugatuck Inspector access to all accounts, bills, payrolls, and vouchers relating to extra work not covered by unit prices, and he agrees that he shall have no claim for compensation for such extra work in the case of items not covered by unit prices, unless a statement in writing of the actual cost of the same, fully itemized as to labor and materials, is presented to the Borough of Naugatuck Inspector before the fifteenth (15th) day of the month following that during which each specific order was complied with by him.

**XXIX Payment**

The Owner, in consideration of the faithful performance by the Contractor of all and singular his covenants, promises, and agreements contained herein, agrees to pay the Contractor for the full completion by him of the work embraced in this Contract, in the manner and within the time herein specified and limited, and to the satisfaction and approval of the Borough of Naugatuck Inspector, the prices stipulated in the said Proposal hereto attached, such payment to be made at the times and in the manner and upon the conditions herein expressly provided. The Owner also agrees to pay in addition such amounts as may be agreed upon for modifications and for extra work.

**XXX Guarantee**

The Contractor guarantees that the work done under this Contract and the materials furnished by him and used in the construction of the same are free from defects or flaws. The guarantee is for a term of one (1) year from, and after, the date upon which the final estimate of the Borough of Naugatuck Inspector is formally approved by the Owner. It is hereby agreed and understood that this guarantee shall not include making any repairs made necessary by any cause or causes other than defective materials furnished by, or defective work done by, the Contractor.

**XXXI Repairs for One (1) Year**

The said party of the second part further agrees that if, at any time during the period of one (1) year from the date of the final estimate of the work herein contracted for, any part of the work done under this Contract shall be deemed by the Borough of Naugatuck Inspector to require repairing under the aforesaid Contractor's guarantee, then the said Owner shall notify the said Contractor to make the repairs so required at no expense to the Owner.

Such replacements, or repairs, shall be undertaken by the Contractor within twenty-four (24) hours after service of notice. If the Contractor unnecessarily delays or fails to make the ordered replacements or repairs within the time specified, or if any replacements or repairs are of such nature as not to allow for the time delay incident to the service of a notice, then the Owner will have the right to make such replacements or repairs, and the expenses thereof shall be paid by the Contractor.

**CTDOT PROJECT #87-146**  
**RUBBER AVENUE AT HOADLEY STREET AND MELBOURNE STREET**  
**TRAFFIC SIGNAL REPLACEMENT PROJECT**  
**Naugatuck, CT**  
**PROPOSAL continued**

**XXXII Rate of Progress and Time of Completion**

The Contractor shall commence work within ten (10) calendar days of the date of the Notice to Proceed. The rate of progress shall be such that the whole work shall be performed and the grounds cleared up in accordance with the Contract and Specifications within Twenty one (21) calendar days unless extensions of time shall be made for the reasons, and in the manner, stated under Article XXXIII, "Extension of Time".

**XXXIII Extension of Time**

The Contractor expressly covenants and agrees that, in undertaking to complete the work within the time mentioned, he has taken into consideration, and made allowance for, all of the ordinary delays and hindrances incidental to such work, whether growing out of delays in securing materials or workmen or otherwise. Should the Contractor, however, be substantially delayed in the prosecution and completion of the work by any changes, additions, or omissions therein ordered in writing by the Borough of Naugatuck Inspector, or by fire, lightning, earthquake, tornado, cyclone, riot, insurrection, or war, or by the abandonment of the work by the workman engaged therein through no fault of the Contractor, or by the discharge of all or any material number of workmen in consequence of difficulties arising between the Contractor and such workmen, or by the neglect, delay, or default of any other contractor of the Owner, then the Contractor may, within five (5) days after the occurrence of the delay for which he claims allowance, notify the Borough of Naugatuck Inspector thereof in writing, and thereupon, and not otherwise, the Contractor shall be allowed such additional time for the completion of the work as the Borough of Naugatuck Inspector, in his discretion, shall award in writing, and his decision shall be final and conclusive upon the parties.

**XXXIV Damages for Failure to Complete on Time**

The Contractor shall pay to the Owner for each and every calendar day (including Saturdays, Sundays, and holidays) that he shall be in default in completing the entire work in the time stipulated in Article XXXII, or within the extension of time he may be granted as provided in Article XXXIII, the sum of One Thousand Eight Hundred Dollars (\$1,800.00) per day. This sum is hereby agreed upon not as a penalty but as liquidated damages which Owner will suffer by reason of such default, time being of the essence of the Contract and a material consideration thereof. The Owner shall have the right to deduct the amount of any such damages from any monies due the Contractor under this Contract.

**XXXV No Waiver of Rights**

No certificate given or payment made under this Contract, except the final certificate or final payment, shall be evidence of the performance of the Contract either wholly or in part, and no payment shall be construed to be an acceptance of defective work or improper materials. No act of the Owner or of the Borough of Naugatuck Inspector, or of any representatives of either of them in inspecting the work, nor any extension of time for the completion of the work, shall be regarded or taken as an acceptance of such work, or any part thereof, or materials used therein or thereof, either wholly or in part; but such acceptance shall be evidenced only by the final certificate of the Borough of Naugatuck Inspector.

Before any final certification shall be allowed, the Contractor shall be required, and he hereby agrees, to sign and attest on said certificate a statement that he accepts the same in full payment and settlement of all claims on account of work done and material furnished under this Contract, and furthermore, that all claims for materials provided or labor performed have been paid and satisfied in full. No waiver of any breach of this Contract by the Owner or anyone acting

**CTDOT PROJECT #87-146**  
**RUBBER AVENUE AT HOADLEY STREET AND MELBOURNE STREET**  
**TRAFFIC SIGNAL REPLACEMENT PROJECT**  
**Naugatuck, CT**  
**PROPOSAL continued**

for it, or on its behalf, shall be held as a waiver of any other or subsequent breach thereof.

**XXXVI Mandatory Negotiation**

Contractor and the Owner agree that they will attempt to negotiate in good faith any dispute of any nature arising under this contract. The parties shall negotiate in good faith at not less than two negotiation sessions prior to seeking any resolution of any dispute under the provisions of arbitration paragraph of this contract. Each party shall have the right to legal representation at any such negotiation session.

**XXXVII Arbitration**

Any dispute or question arising under the provisions of this contract which has not been resolved under the mandatory negotiation paragraph of this contract shall be determined by arbitration. Arbitration proceedings shall occur at a neutral location in Waterbury, Connecticut, and shall be conducted in accordance with the rules then applicable of the American Arbitration Association. Arbitration shall proceed before a panel of one arbitrator to be selected by American Arbitration Association. The decision of the Arbitrator shall be final and may be entered in any court having jurisdiction thereof. Each party shall pay one-half of all costs and expenses of such arbitration.

**XXXVIII Owner's Right to Use**

The Owner reserves the right to use or occupy any portion of the work considered by the Borough of Naugatuck Inspector as ready for use or occupancy. Such use or occupancy shall not be held, in any way, as final acceptance of the work or any portion thereof, or as a waiver of any portion of this Contract.

**XXXIX Verification of Data**

The quantities of work to be done and the materials to be furnished under this Contract, as given in the accompanying "Information for Bidders" and on the Proposal form, are approximate estimates for the purpose of comparing bids on a uniform basis. Neither the Owner nor the Borough of Naugatuck Inspector are to be held responsible for the data or information given relative to said quantities or that given on the Plans relative to existing conditions. The Contractor has judged for himself as to such quantities and as to other circumstances affecting the cost of the performance of this Contract, and he shall not at any time assert that there was any misunderstanding in regard to the character or amount of work to be done and materials and labor to be furnished.

**XXXX Contractor's Wage Certification Form**

If applicable the Contractor or his authorized agent will be required to sign the Contractor's Wage Certification Form at the time of Contract execution.

**XXXXI Verbal Statements Not Binding**

It is understood and agreed that the written terms and provisions of this Agreement shall supersede all prior verbal statements of the Borough of Naugatuck Inspector or other representatives of the Owner, and such statements shall not be effective or be construed as entering into or forming a part of, or altering in anyway whatsoever, the written Agreement.

**CTDOT PROJECT #87-146**  
**RUBBER AVENUE AT HOADLEY STREET AND MELBOURNE STREET**  
**TRAFFIC SIGNAL REPLACEMENT PROJECT**  
**Naugatuck, CT**  
**PROPOSAL continued**

XXXXII Final Estimate Constitutes Release

It is agreed that acceptance by the Contractor of the last payment made, under the provisions of Article XXVII, shall operate as and shall be a release to the Owner, and every agent thereof, from all claims and liability to Contractor for anything done or furnished for, or relating to, the work or for any act or neglect of the Owner or of any agent thereof, except any claim against the Owner for the remainder, if any, of the amounts kept or retained by the Owner as percentages or deductions.

No payment, however, final or otherwise, shall operate to release the Contractor or his sureties from any obligations under this Contract.

XXXXIII Delays or Termination by Governmental Authorities

Notwithstanding any other provision(s) of this contract, the parties agree that in the event of a stop work order from the State Department of Transportation, Department of Environmental Protection, or any other State or Federal agency, no additional compensation will be made by Owner to Contractor for delays, inconvenience or damage sustained by Contractor due to such order, including, without limitation, damages for loss of use of equipment or idle equipment. Similarly, in the event of a termination of the project by the State DOT, DEP or any other State or Federal agency, no additional compensation will be made by Owner to Contractor for the termination, or for any delay, inconvenience or damage sustained by Contractor due to such termination, including, without limitation, damages for loss of use of equipment or idle equipment. In the event of such termination, the Borough of Naugatuck Inspector shall prepare a final certificate for the entire amount of work done up to the effective date of termination. The provisions of Sections XXX (Guarantee) and XXXI (Repair) shall apply to all work completed as of the effective date of any stop Work order, as if the effective date was the date upon which the final estimate of the Borough of Naugatuck Inspector is formally approved by the Borough.

XXXXIV Validity of Agreement

The provision of this Agreement shall be binding upon the Parties and their respective successor or assigns.

IN WITNESS WHEREOF, the said parties hereto have caused this instrument to be signed by their respective duly constituted officers, attested, and sealed pursuant to proper resolutions.

Signed and sealed  
in the presence of

\_\_\_\_\_  
\_\_\_\_\_  
\_\_\_\_\_  
\_\_\_\_\_

Contractor

\_\_\_\_\_  
Borough of Naugatuck  
Mayor

\_\_\_\_\_  
(Duly Authorized)

**CTDOT PROJECT #87-146**  
**RUBBER AVENUE AT HOADLEY STREET AND MELBOURNE STREET**  
**TRAFFIC SIGNAL REPLACEMENT PROJECT**  
**Naugatuck, CT**  
**PROPOSAL continued**

**CERTIFICATE AS TO CORPORATE PRINCIPAL**

I, \_\_\_\_\_ certify that I am the \_\_\_\_\_ of the Corporation named as Contractor in the within bond; that \_\_\_\_\_, who signed the said bond on behalf of the Contractor was then \_\_\_\_\_ of said corporation; that I know his signature, and his signature thereto is genuine; and that said bond was duly signed, sealed, and attested to for and in behalf of said corporation by authority of this governing body.

\_\_\_\_\_  
(Corporate Seal)

\_\_\_\_\_  
Title

**CTDOT PROJECT #87-146**  
**RUBBER AVENUE AT HOADLEY STREET AND MELBOURNE STREET**  
**TRAFFIC SIGNAL REPLACEMENT PROJECT**  
**Naugatuck, CT**  
**PROPOSAL continued**

**SECTION F**

**PERFORMANCE BOND**

**CTDOT PROJECT #87-146**  
**RUBBER AVENUE AT HOADLEY STREET AND MELBOURNE STREET**  
**TRAFFIC SIGNAL REPLACEMENT PROJECT**

**Naugatuck, CT**  
**PROPOSAL continued**

**PERFORMANCE BOND**

KNOW ALL MEN BY THESE PRESENTS: that

\_\_\_\_\_  
(Name of Contractor)

\_\_\_\_\_  
(Address of Contractor)

a \_\_\_\_\_, hereinafter called Principal and  
(Corporation, Partnership, or Individual)

\_\_\_\_\_  
(Name of Surety)

\_\_\_\_\_  
(Address of Surety)

hereinafter called Surety, are held and firmly bound unto

\_\_\_\_\_  
(Name of Owner)

\_\_\_\_\_  
(Address of Owner)

hereinafter called OWNER, in the penal sum of \_\_\_\_\_ Dollars,  
\$(\_\_\_\_\_) in lawful money of the United States, for the payment of which sum well and truly  
to be made, we bind ourselves, successors, and assigns, jointly and severally, firmly by these  
presents.

THE CONDITION OF THIS OBLIGATION is such that whereas, the Principal entered into a  
certain contract with the OWNER, dated the \_\_\_\_ day of \_\_\_\_\_, 20\_\_\_\_, a copy of  
which is hereto attached and made a part hereof for the construction of:

NOW, THEREFORE, if the Principal shall well, truly and faithfully perform its duties, all the  
undertakings, covenants, terms, conditions, and agreements of said contract during the original  
term thereof, and any extensions thereof which may be granted by the OWNER, with or without  
notice to the Surety and during the one year guaranty period, and if he shall satisfy all claims and  
demands incurred under such contract, and shall fully indemnify and save harmless the OWNER  
from all costs and damages which may suffer by reason of failure to do so, and shall reimburse  
and repay the OWNER all outlay and expense which the OWNER may incur in making good any  
default, then this obligation shall be void; otherwise to remain in full force and effect.

PROVIDED, FURTHER, that the said surety, for value received hereby stipulates and agrees that  
no change, extension of time, alteration or addition to the terms of the contract or to WORK to be  
performed thereunder or the SPECIFICATIONS accompanying the same shall in anyway affect  
its obligation on this BOND, and it does hereby waive notice of any such change, extension of  
time, alteration or addition to the terms of the contract or to the WORK or to the  
SPECIFICATIONS.

PROVIDED, FURTHER, that no final settlement between the OWNER and the CONTRACTOR  
shall abridge the right of any beneficiary hereunder, whose claim may be unsatisfied.

**CTDOT PROJECT #87-146**  
**RUBBER AVENUE AT HOADLEY STREET AND MELBOURNE STREET**  
**TRAFFIC SIGNAL REPLACEMENT PROJECT**  
**Naugatuck, CT**  
**PROPOSAL continued**

IN WITNESS WHEREOF, this instrument is executed in \_\_\_\_\_ counterparts each one of which shall be deemed an original, this the \_\_\_\_\_ day of \_\_\_\_\_, 20\_\_.

ATTEST:

\_\_\_\_\_  
(Principal) Secretary

By \_\_\_\_\_(s)  
Principal

(SEAL)

\_\_\_\_\_  
(Witness as to Principal)

\_\_\_\_\_  
(Address)

\_\_\_\_\_  
(Address)

\_\_\_\_\_

\_\_\_\_\_  
Surety

ATTEST:

\_\_\_\_\_  
(Surety) Secretary

(SEAL)

\_\_\_\_\_  
(Witness as to Surety)

By \_\_\_\_\_  
(Attorney-in-Fact)

\_\_\_\_\_  
(Address)

\_\_\_\_\_  
(Address)

NOTES: If CONTRACTOR is Partnership, all partners should execute BOND.

IMPORTANT: Surety companies executing BONDS must appear on the Treasury Department's most current list (Circular 570 as amended) and be authorized to transact business in the state where the PROJECT is located.



**CTDOT PROJECT #87-146**  
**RUBBER AVENUE AT HOADLEY STREET AND MELBOURNE STREET**  
**TRAFFIC SIGNAL REPLACEMENT PROJECT**

**Naugatuck, CT**  
**PROPOSAL continued**

**SECTION G**

**PAYMENT BOND**

**CTDOT PROJECT #87-146**  
**RUBBER AVENUE AT HOADLEY STREET AND MELBOURNE STREET**  
**TRAFFIC SIGNAL REPLACEMENT PROJECT**  
**Naugatuck, CT**  
**PROPOSAL continued**

**PAYMENT BOND**

KNOW ALL MEN BY THESE PRESENTS: that

\_\_\_\_\_  
(Name of Contractor)

\_\_\_\_\_  
(Address of Contractor)

a \_\_\_\_\_, hereinafter called Principal and  
(Corporation, Partnership, or Individual)

\_\_\_\_\_  
(Name of Surety)

\_\_\_\_\_  
(Address of Surety)

hereinafter called Surety, are held and firmly bound unto

\_\_\_\_\_  
(Name of Owner)

\_\_\_\_\_  
(Address of Owner)

hereinafter called OWNER, in the penal sum of

\_\_\_\_\_ Dollars, \$(\_\_\_\_\_)

in lawful money of the United States, for the payment of which sum well and truly to be made, we bind ourselves, successors, and assigns, jointly and severally, firmly by these presents.

THE CONDITION OF THIS OBLIGATION is such that whereas, the Principal entered into a certain contract with the OWNER, dated the \_\_\_\_\_ day of \_\_\_\_\_, 20\_\_ , a copy of which is hereto attached and made a part hereof for the construction of:

NOW, THEREFORE, if the Principal shall well, truly and faithfully perform its duties, all the undertakings, covenants, terms, conditions, and agreements of said contract during the original term thereof, an any extensions thereof which may be granted by the OWNER, with or without notice to the Surety and during the one year guaranty period, and if he shall satisfy all claims and demands incurred under such contract, and shall fully indemnify and save harmless the OWNER from all costs and damages which may suffer by reason of failure to do so, and shall reimburse and repay the OWNER all outlay and expense which the OWNER may incur in making good any default, then this obligation shall be void; otherwise to remain in full force and effect.

PROVIDED, FURTHER, that the said surety, for value received hereby stipulates and agrees that no change, extension of time, alteration or addition to the terms of the contract or to WORK to be

**CTDOT PROJECT #87-146**  
**RUBBER AVENUE AT HOADLEY STREET AND MELBOURNE STREET**  
**TRAFFIC SIGNAL REPLACEMENT PROJECT**  
**Naugatuck, CT**  
**PROPOSAL continued**

performed thereunder or the SPECIFICATIONS accompanying the same shall in anyway affect its obligation on this BOND, and it does hereby waive notice of any such change, extension of time, alteration or addition to the terms of the contract or to the WORK or to the SPECIFICATIONS.

PROVIDED, FURTHER, that no final settlement between the OWNER and the CONTRACTOR shall abridge the right of any beneficiary hereunder, whose claim may be unsatisfied.

IN WITNESS WHEREOF, this instrument is executed in \_\_\_\_\_ counterparts each one of which shall be deemed an original, this the \_\_\_\_\_ day of \_\_\_\_\_, 20\_\_.

ATTEST:

\_\_\_\_\_  
(Principal) Secretary

Principal  
By \_\_\_\_\_(s)

(SEAL)

\_\_\_\_\_  
(Witness as to Principal)

\_\_\_\_\_  
(Address)

\_\_\_\_\_  
(Address)

\_\_\_\_\_  
Surety

ATTEST:

\_\_\_\_\_  
(Surety) Secretary

(SEAL)

\_\_\_\_\_  
Witness as to Surety

By \_\_\_\_\_  
Attorney-in-Fact

\_\_\_\_\_  
(Address)

\_\_\_\_\_  
(Address)

IMPORTANT: Surety companies executing BONDS must appear on the Treasury Department's most current list (Circular 570 as amended) and be authorized to transact business in the state where the PROJECT is located.

**CTDOT PROJECT #87-146**  
**RUBBER AVENUE AT HOADLEY STREET AND MELBOURNE STREET**  
**TRAFFIC SIGNAL REPLACEMENT PROJECT**  
**Naugatuck, CT**  
**PROPOSAL continued**

**SECTION H**  
**SPECIFICATIONS**

DATE: 05/03/2017  
FEDERAL AID PROJECT NO. 1087(113)  
STATE PROJECT NO. 87-146

RUBBER AVENUE AT HOADLEY STREET AND MELBOURNE STREET  
TRAFFIC SIGNAL REPLACEMENT

Borough of Naugatuck

The State of Connecticut, Department of Transportation, Standard Specifications for Roads, Bridges, Facilities and Incidental Construction, Form 817, 2016, (otherwise referred to collectively as "ConnDOT Form 817") is hereby made part of this contract, as modified by the Special Provisions contained herein. The current edition of the State of Connecticut Department of Transportation's "Construction Contract Bidding and Award Manual" ("Manual"), is hereby made part of this contract. If the provisions of this Manual conflict with provisions of other Department documents (not including statutes or regulations), the provisions of the Manual will govern. The Manual is available upon request from the Transportation Manager of Contracts.

**CONTRACT TIME AND LIQUIDATED DAMAGES**

Ninety (90) calendar days will be allowed for completion of the work on this project and the liquidated damages charge to apply will be One Thousand Eight Hundred Dollars (\$1,800) per calendar day.

**NOTICE TO CONTRACTOR - CONTRACT DURATION**

The Contractor is hereby notified that this is not to be considered an ordinary project by any means and that due to the inconvenience to the traveling public that it causes, extra manpower, equipment and workshifts may be required to complete the work in accordance within the specified contract time.

## **NOTICE TO CONTRACTOR - PROCUREMENT OF MATERIALS**

Upon award, the Contractor shall proceed with shop drawings, working drawings, procurement of materials, and all other submittals required to complete the work in accordance with the contract documents.

**NOTICE TO CONTRACTOR – SITE CLEANLINESS**

The Contractor is hereby notified that all areas utilized for construction activities including all onsite and offsite facilities shall be maintained so as to be free of rubbish, trash and deleterious construction debris at all times. The use of covered and secured trash receptacles is required. All receptacles will be regularly emptied and maintained.

There will be no direct payment for maintaining the site cleanliness of the construction areas under the contract.



## **NOTICE TO CONTRACTOR - TRAFFIC SIGNALS**

The Contractor is hereby notified that certain conditions pertaining to the installation of new signals and maintenance of traffic signal operations are required when relevant, as part of this contract.

### **Qualified/Unqualified Workers**

#### **U.S. Department of Labor**

**Occupational Safety & Health Administration (OSHA) [www.osha.gov](http://www.osha.gov)**

**Part Number 1910**

**Part Title Occupational Safety & Health Administration**

**Subpart S**

**Subpart Title Electrical**

**Standard Number 1910.333**

**Title Selection and use of work practices**

**Completion of this project will require Contractor employees to be near overhead utility lines. All workers and their activities when near utility lines shall comply with the above OSHA regulations. In general, unqualified workers are not allowed within 10 feet of overhead, energized lines. It is the contractor's responsibility to ensure that workers in this area are qualified in accordance with OSHA regulations.**

**The electric distribution company is responsible to provide and install all necessary anchors and guy strands on utility poles. It is the Contractors responsibility to coordinate with the utility company to ensure proper placement of the anchor.**

The Controller Unit (CU) shall conform to the current edition of the Functional Specifications for Traffic Control Equipment. The Functional Specifications require the CU meet NEMA Standard Publication No. TS2-1992 Type 2. The Functional Specifications are available on the Departments' web site <http://www.ct.gov/dot/site/default.asp>, click on "Doing Business with CONNDOT", under Engineering Resources click on "Traffic Engineering", Scroll down to Traffic Documents click on "Functional\_Specifications\_for\_Traffic\_Control\_Equip.pdf".

Utility poles cannot be double loaded without proper guying.

The contractor will be held liable for all damage to existing equipment resulting from his or his subcontractor's actions. A credit will be deducted from monies due the Contractor for all maintenance calls responded to by the Borough.

All existing traffic appurtenances, in particular steel span poles, controller cabinets and pedestals shall be removed from the proposed roadway prior to excavation. The Contractor shall work with the utility companies to either relocate or install all traffic signal appurtenances prior to the roadway reconstruction.

The Contractor must install permanent or temporary spans in conjunction with utility company relocations. He then must either install the new signal equipment and controller or relocate the existing equipment.

The 30 Day Test on traffic control equipment, as specified in Section 10.00, Article 10.00.10 – TESTS, will not begin until the items listed below are delivered to the Borough.

Four (4) sets of cabinet wiring diagrams. Leave one set in the controller cabinet.  
All spare load switches and flash relays.

**NOTICE TO CONTRACTOR – VERIFICATION OF PLAN DIMENSIONS  
AND FIELD MEASUREMENTS**

The Contractor is responsible for verifying all dimensions before any work is begun. Dimensions of the existing structures shown on the plans are for general reference only; they are not guaranteed. The Contractor shall take all field measurements necessary to assure proper fit of the finished work and shall assume full responsibility for their accuracy. When shop drawings and/or working drawings based on field measurements are submitted for approval and/or review, the field measurements shall also be submitted for reference by the reviewer.

In the field, the Contractor shall examine and verify all existing and given conditions and dimensions with those shown on the plans. If field conditions and dimensions differ from those shown on the plans, the Contractor shall use the field conditions and dimensions and make the appropriate changes to those shown on the plans as approved by the Engineer. All field conditions and dimensions shall be so noted on the drawings submitted for approval.

There shall be no claim made against the Department by the Contractor for work pertaining to modifications required by any difference between actual field conditions and those shown by the details and dimensions on the contract plans. The Contractor will be paid at the unit price bid for the actual quantities of materials used or for the work performed, as indicated by the various items in the contract.

## **NOTICE TO CONTRACTOR – CONTRACTOR TRAINING REQUIREMENT FOR 10-HOUR OSHA CONSTRUCTION SAFETY AND HEALTH COURSE**

In accordance with Connecticut General Statute 31-53b and Public Act No. 08-83, the Contractor is required to furnish proof that any person performing the work of a mechanic, laborer or worker pursuant to the classifications of labor under section 31-53, has completed a course of at least ten hours in duration in construction safety and health approved by the Federal Occupational Safety and Health Administration or, has completed a new miner training program approved by the Federal Mine Safety and Health Administration in accordance with 30 CFR 48 or, in the case of telecommunications employees, has completed at least ten hours of training in accordance with 29 CFR 1910.268.

Proof of compliance with the provisions of the statute shall consist of a student course completion card issued by the federal Occupational Safety and Health Administration, or other such proof as deemed appropriate by the Commissioner of the Connecticut Department of Labor, dated no earlier than five years prior to the commencement of the project. Each employer shall affix a copy of the construction safety course completion card for each applicable employee to the first certified payroll submitted to the Department of Transportation on which the employee's name first appears.

Any employee required to complete a construction safety and health course as required that has not completed the course, shall have a maximum of fourteen (14) days to complete the course. If the employee has not been brought into compliance, they shall be removed from the project until such time as they have completed the required training.

This section does not apply to employees of public service companies, as defined in section 16-1 of the 2008 supplement to the General Statutes, or drivers of commercial motor vehicles driving the vehicle on the public works project and delivering or picking up cargo from public works projects provided they perform no labor relating to the project other than the loading and unloading of their cargo.

The internet website for the federal Occupational Safety and Health Training Institute is <http://www.osha.gov/fso/ote/training/edcenters>.

Additional information regarding this statute can be found at the Connecticut Department of Labor website, <http://www.ctdol.state.ct.us/wgwkstnd/wgemenu.htm>.

Any costs associated with this notice shall be included in the general cost of the contract. In addition, there shall be no time granted to the contractor for compliance with this notice. The contractor's compliance with this notice and any associated regulations shall not be grounds for claims as outlined in Section 1.11 – "Claims".

## **NOTICE TO CONTRACTOR – PROTECTION OF WATERWAY**

The Contractor's operations shall conform to the following general conditions:

- 1) Positive means shall be taken to prevent any debris, tools or construction material from entering the watercourse.
- 2) During the progress of work, should any material, machinery or equipment be lost, dumped, thrown overboard, or sunk so as to obstruct, interfere with or hazard navigation, immediate notice shall be given to the Water Resources Unit of the Connecticut Department of Energy and Environmental Protection at 860-566-7220, and the object removed immediately. Until removal can be effected, the obstruction shall be properly marked in order to protect navigation. Notice to the Water Resources Unit shall give a description and location of any such object and the action taken to protect navigation.
- 3) Spillage of oil and hazardous substances is specifically prohibited by Section 311 of the Federal Water Pollution Control Act of 1972, as amended. Measures should be taken including: (1) proper maintenance of construction equipment, (2) arrangement of fuel/hazardous substances handling areas so as to ensure that any spills are contained before reaching navigable waterways or their adjoining shorelines, (3) instructions to personnel not to dispose of oil/hazardous substances into drains or the navigable waterways directly or onto adjoining shorelines, and (4) any other procedures to prohibit spillage. If in spite of such planning oil/hazardous substances are spilled into a navigable waterway or adjoining shoreline, the Connecticut Department of Energy and Environmental Protection (Conn. D.E.E.P.) is to be notified immediately at 860-566-4924. A supply of an absorbent material should be retained so that it may be rapidly deployed to soak up any possible spillage, pending Conn. D.E.E.P. arrival on scene. The use of chemical dispersing agents and emulsifiers is not authorized without prior, specific D.E.E.P. approval.

## **NOTICE TO CONTRACTOR - PROTECTION OF EXISTING UTILITIES**

The Contractor's attention is directed to the need for the protection of the existing underground utilities, during the construction of the proposed structures.

Representatives of the various utility companies shall be allowed access to the work.

The contractor shall be liable for all damages or claims received or sustained by any persons, corporations or property in consequence of damage to the existing utilities, their appurtenances, or other facilities caused directly or indirectly by the operations of the contractor.

Any damage to any existing utility shall be repaired including all materials, labor, etc., to the Engineer's and/or respective utility company's satisfaction at no cost to the Owner, Borough of Naugatuck, State of Connecticut, or its representative.

The contractor's attention is directed to the requirements of Article 1.07.13 – Contractor's Responsibility for Adjacent Property and Services. The contractor shall provide a minimum three feet nominal cover, and equipment wheel loads shall not exceed 24,000 lbs. where construction equipment traverses watermains.

Prior to opening an excavation, effort shall be made to determine whether underground installations, i.e., sewer, gas, electric lines, etc., will be encountered and, if so, the contractor shall notify the utility before continuing excavation work near their facility at least two days in advance of the excavation near the facility where such underground installations are located. When the excavation approaches the estimated location of such an installation, the exact location shall be determined by careful probing or hand digging, and when it is uncovered, proper supports shall be provided for the existing installation. Utility companies shall be contacted and advised of proposed work prior to the start of actual excavation. The following utilities shall be contacted prior to excavation near any utilities:

Gas:	Water:
Yankee Gas Services Company	The Connecticut Water Company
Mr. Thomas Costa	Mr. Daniel Lesnieski
Manager Gas Project Engineering	Infrastructure Rehabilitation Manager
157 Cordaville Road	446 Smith Street
Southborough, MA 01772	Middletown, CT 06457
(508) 305-7027	(860) 292-2834
Thomas.Costa@eversource.com	dlesnieski@ctwater.com

In order to notify utility companies, the number 1-800-922-4455 (Call Before You Dig) must be called at least forty-eight (48) hours prior to the start of excavation. This notification will enable the utility companies to mark out their facilities in the field.

**NOTICE TO CONTRACTOR – BUY AMERICA**

The Contractor agrees to comply with 23 U.S.C. 313 and 23 CFR 635.410, which provide that Federal funds may not be obligated unless steel, iron, and manufactured products used on Federal Highway Administration (FHWA) –funded projects are produced in the United States, unless a waiver has been granted by FHWA or the product is subject to a general waiver. General waivers are listed in 23 CFR 635.410(c)(1).

**NOTICE TO CONTRACTOR – THURSTON ENERGY SIGN**

The Contractor is hereby notified that a sign owned by Thurston Energy located on the Roadway Plan shall be removed and stored per agreement with Thurston Energy. The work for the item shall be paid under Item 1206023A – Removal and Relocation of Existing Sign.



## **NOTICE TO CONTRACTOR – UTILITY GENERATED SCHEDULE**

The attached project specific utility work schedules were provided to the Connecticut Department of Transportation (Department) by the utility companies regarding their identified work on this project.

The utility scheduling information is provided to assist the Contractor in scheduling its activities. However, the Department does not ensure its accuracy and Section 1.05.06 of the Standard Specifications still is in force.

The utility scheduling information shall be incorporated into the Contractor's pre-award schedule in accordance with the Department's Bidding and Award Manual and Section 1.05.08 of the Contract.

After award, the Contractor shall conduct a utility coordination meeting or meetings to obtain contemporaneous scheduling information from the utilities prior to submitting its baseline schedule to the Department in accordance with Section 1.05.08 of the Contract.

The Contractor shall incorporate the contemporaneous utility scheduling information into its baseline schedule submittal. The baseline schedule shall include Contractor predecessor and successor activities to the utility work in such detail as acceptable to the Engineer.

**UTILITY WORK SCHEDULE Rev 08 02 2016**

CTDOT Project Number: 87-146	Town: Naugatuck
------------------------------	-----------------

Project Description: Intersection Improvement-Rubber Ave. at Hoadley & Melbourne Streets

CTDOT Utilities Engineer: Greg Chhabra

Phone: 860-594-3268	Email: greg.chhabra@ct.gov
---------------------	----------------------------

Utility Company: Comcast

Prepared By: Rich Guy	Date Prepared: 7/28/2018
-----------------------	--------------------------

Phone: 203-732-0146x578385	Email: rich_guy2@comcast.com
----------------------------	------------------------------

**Scope of Work**

The following is a description of all utility work planned to be completed in conjunction with the CTDOT project. The narrative describes all work to be carried out by the utility or its contractor, including temporary and permanent work required by the project as well as any additional utility infrastructure work the utility intends on performing within the project limits during the construction of the project.

When new poles have been placed and power company has transferred all of their facilities Comcast will be begin to relocate their facilities

**Special Considerations and Constraints**

The following describes the limiting factors that must be planned for in the scheduling and performance of the utility work. For example, restrictions on cut-overs, outages, limitations on customer service interruptions (e.g. nights, weekends, holidays), seasonal and environmental shutdown periods, long lead material procurements, etc..



## UTILITY WORK SCHEDULE Rev 3/2015

CTDOT Project Number: 87-146 Town: NAUGATUCK

Project Description: RUBBER AVE INTERSECTION AT HOADLEY AND MELBOURNE

CTDOT Utilities Engineer: GREG CHHABRA

Phone: (860)594-3268 Email: greg.chhabra@ct.gov

Utility Company: CROWN CASTLE FIBER

Prepared By: TERENCE J SHEA Date Prepared: 11/27/2017

Phone: (203)649-3905 Email: tshea@lighttower.com

### Scope of Work

The following is a description of all utility work planned to be completed in conjunction with the CTDOT project. The narrative describes all work to be carried out by the utility or its contractor, including temporary and permanent work required by the project as well as any additional utility infrastructure work the utility intends on performing within the project limits during the construction of the project.

Crown Castle Fiber's work will consist of shifting 3 fiber optic cables to relocated poles.

### Special Considerations and Constraints

The following describes the limiting factors that must be planned for in the scheduling and performance of the utility work. For example, restrictions on cut-overs, outages, limitations on customer service interruptions (e.g. nights, weekends, holidays), seasonal and environmental shutdown periods, long lead material procurements, etc..

PLEASE NOTE THAT ANY TIME FRAME GIVEN AS A START TIME OR DURATION OF WORK CAN BE AFFECTED BY MANY FACTORS INCLUDING, BUT NOT LIMITED TO, MAKE READY WORK, OTHER UTILITIES, PERMIT APPLICATIONS, CHANGES IN SCOPE, INCLEMENT WEATHER, HOLIDAYS AND EMERGENCY SITUATIONS.



**UTILITY WORK SCHEDULE Rev 08 02 2016**

CTDOT Project Number:	87-146	Town:	Naugatuck
Project Description:	Rubber Av traffic light at Hoadley & Melbourne Streets		
CTDOT Utilities Engineer:	Greg Chhabra		
Phone:	(860) 594-3268	Email:	greg.chhabra@ct.gov

Utility Company:	Frontier Communications		
Prepared By:	Gary Swanson	Date Prepared:	1/11/2018
Phone:	(203) 575-6112	Email:	gary.k.swanson@ftr.com

**Scope of Work**

The following is a description of all utility work planned to be completed in conjunction with the CTDOT project. The narrative describes all work to be carried out by the utility or its contractor, including temporary and permanent work required by the project as well as any additional utility infrastructure work the utility intends on performing within the project limits during the construction of the project.

This traffic light project will relocate 3 Frontier poles and remove 1 Frontier pole. Once the edge of road (curb line), property lines and CBYD are marked out Frontier can place the 3 new poles. After poles are set guying will be placed. After all other utililtes have shifted to the new poles, Frontier can shift to the new poles and remove old. The pole that needs to be removed will be removed when the new poles are being placed.

**Special Considerations and Constraints**

The following describes the limiting factors that must be planned for in the scheduling and performance of the utility work. For example, restrictions on cut-overs, outages, limitations on customer service interruptions (e.g. nights, weekends, holidays), seasonal and environmental shutdown periods, long lead material procurements, etc..



## UTILITY WORK SCHEDULE Rev 3/2015

CTDOT Project Number:	0087-0146	Town:	Naugatuck
-----------------------	-----------	-------	-----------

Project Description:	Rubber Ave - Relocate Poles
----------------------	-----------------------------

CTDOT Utilities Engineer:	Greg Chhabra
---------------------------	--------------

Phone:	860-594-3268	Email:	Greg.Chhabra@po.state.ct.us
--------	--------------	--------	-----------------------------

Utility Company:	Eversource
------------------	------------

Prepared By:	Mike DeFrancesco	Date Prepared:	23-Nov-16
--------------	------------------	----------------	-----------

Phone:	203-271-4834	Email:	deframj@nu.com
--------	--------------	--------	----------------

### Scope of Work

The following is a description of all utility work planned to be completed in conjunction with the CTDOT project. The narrative describes all work to be carried out by the utility or its contractor, including temporary and permanent work required by the project as well as any additional utility infrastructure work the utility intends on performing within the project limits during the construction of the project.

Eversource or it's assigned contractor(s) to shift electric facilities to relocated poles 1356 & 1357 on Rubber Avenue Naugatuck at the intersections of Hoadley Street and Melbourne Street after poles have been relocated by Frontier or it's assigned contractor(s). Eversource to relocate pole G3454S and anchor and shift electric facilities.

### Special Considerations and Constraints

The following describes the limiting factors that must be planned for in the scheduling and performance of the utility work. For example, restrictions on cut-overs, outages, limitations on customer service interruptions (e.g. nights, weekends, holidays), seasonal and environmental shutdown periods, long lead material procurements, etc..





## **NOTICE TO CONTRACTOR - ALL-INCLUSIVE DRAINAGE**

### **ADDED SECTIONS:**

#### **2.86 – DRAINAGE TRENCH EXCAVATION**

#### **ROCK IN DRAINAGE TRENCH EXCAVATION**

#### **5.86 – CATCH BASINS, MANHOLES AND DROP INLETS**

#### **6.86 – DRAINAGE PIPES**

#### **DRAINAGE PIPE ENDS**

This Contract contains the above-noted Special Provisions for all-inclusive drainage, developed to replace the following Sections in their entireties:

- Section 5.07 – *Catch Basins, Manholes and Drop Inlets*
- Section 6.51 – *Culverts*
- Section 6.52 – *Culvert Ends*

The Section 5.86 and 6.86 items include excavation and bedding material in the drainage structure, pipe and pipe end unit prices.

Section 2.05 *Trench Excavation* may be included for miscellaneous trenching, where necessary, but will not be used with all-inclusive drainage items.

Other Standard Specifications, Supplemental Specifications or Special Provisions may contain references to Articles or Subarticles from previous versions of Sections 5.07, 6.51 and 6.52 which are no longer valid.

The following Standard Specifications Sections or Supplements contain references to Articles or Subarticles from Section 2.05 which shall remain in effect:

- Section 2.06 – *Ditch Excavation*
- Section 5.06 – *Retaining Walls, Endwalls and Steps*
- Section 7.51 – *Underdrains and Outlets*
- Section 10.01 – *Trenching and Backfilling*

‘Rock in Drainage Trench Excavation’ is now defined in Section 2.86. ‘Rock in Trench Excavation’ will remain in Section 2.05 and may be used with trenching not associated with all-inclusive drainage items.

**Any references to Articles beginning with “5.07,” “6.51,” or “6.52” shall refer to the pertinent topic or materials in the new Special Provisions contained herein.**

## **SECTION 1.05 - CONTROL OF THE WORK**

**Article 1.05.02** - Plans, Working Drawings and Shop Drawings  
is supplemented as follows:

**Subarticle 1.05.02** - (2) is supplemented by the following:

### **Traffic Signal Items:**

When required by the contract documents or when ordered by the Engineer, The Contractor shall prepare and submit product data sheets, working drawings and/or shop drawings for all traffic signal items, except Steel Span Poles and Mast Arm Assemblies when applicable, to the “Engineer of Record” for review before fabrication. The packaged set of product data sheets, working drawings and/or shop drawings shall be submitted in an electronic portable document format (.pdf).

The packaged set submitted in an electronic portable document format (.pdf) shall be in an individual file with appropriate bookmarks for each item. The electronic files for product data sheets shall be created on ANSI A (8 ½” x 11”; 216 mm x 279mm; letter) sheets. Working drawings and shop drawings shall be created on ANSI B (11” x 17”; 279 mm x 432 mm; ledger/tabloid) sheets.

Please send a PDF copy of the approved documents via email to:

[DOT.TrafficElectrical@ct.gov](mailto:DOT.TrafficElectrical@ct.gov)

### **Steel Span Pole Assemblies:**

When these items are included in the project, the submission for Steel Span Pole Assemblies shall follow the format and be sent to the “Engineer of Record” as described in the Steel Span Pole Assembly special provision.

## **SECTION 1.06 CONTROL OF MATERIALS**

**Article 1.06.01** - Source of Supply and Quality:

Add the following:

### **Traffic Signal Items:**

For the following traffic signal items the contractor shall submit a complete description of the item, shop drawings, product data sheets and other descriptive literature which completely illustrates such items presented for formal review. Such review shall not change the requirements for a certified test report and materials certificate as may be called for. All documents shall be grouped into one separate file for each group of items as indicated by the Roman numerals below (for example, one pdf file for all of the pedestal items). The documents for all of the traffic signal items shall be submitted at one time, unless otherwise allowed by the engineer.

- I. 11020XX – Aluminum Pedestals
- II. 11050XXA – Traffic Signals, Span Mounted - LEDs, Housings and Hardware  
11053XXA – Traffic Signals, Pedestal Mounted - LEDs, Housings and Hardware
- III. 11060XXA – Pedestrian Signals - LEDs, Housings, and Hardware  
11070XXA – Accessible Pedestrian Signal & Detector - Button, Housings & Sign (Type)
- IV. 11XXXXXA – Optical Pre-Emption - Emitter, Detector, Phase Selector and Chassis
- V. 11114XXA – Loop Detector Amplifier, Sealant, Wire and Lead in Wire

## **SECTION 1.07 - LEGAL RELATIONS AND RESPONSIBILITIES**

**Article 1.07.13** - Contractor's Responsibility for Adjacent Property, Facilities and Services is supplemented as follows:

The following company and representative shall be contacted by the Contractor to coordinate the protection of their utilities on this project 30 days prior to the start of any work on this project involving their utilities:

Mr. Mark Russo (Acting)  
District 4 Electrical Supervisor  
Department of Transportation  
Southbury, Connecticut 06488  
(203) 264-9590

Ms. Lynne Delucia  
Frontier  
(203) 238-5000  
Lynne.m.delucia@ftr.com

Mr. Jim Bitzas  
Comcast of Connecticut  
Jim\_bitzas@cable.comcast.com  
(413) 562-9923

Yankee Gas Services Company  
Mr. Thomas Costa  
(508) 305-7027  
Thomas.Costa@eversource.com

Mr. Eric Clark  
Lighttower  
(203)649-3904  
Eric.Clark@crowncastle.com

Mr. Thomas Woronik  
Eversource  
Thomas.Woronik@eversource.com  
(203) 271-4783

The Connecticut Water Company  
Mr. Daniel Lesnieski  
(860) 292-2834  
dlesnieski@ctwater.com

The local Building Department shall be contacted for electrical service inspections for controllers located on Borough roads located within the respective municipality.

Bill Herzman  
229 Church Street, 3<sup>rd</sup> Floor  
203-720-7065

Please provide the electrical service request number provided by the power company. This is a Work Request (WR) Number provided by Eversource (formerly Northeast Utilities [CL&P]).

## **SECTION 1.08 - PROSECUTION AND PROGRESS**

### **Article 1.08.03 - Prosecution of Work:**

Add the following:

The Contractor will not be allowed to install traffic signal or pedestrian heads until the controllers are on hand and ready for installation. Once installation of this equipment commences, the Contractor shall complete this work in a most expeditious manner.

The Contractor shall notify the project engineer on construction projects, or the district permit agent on permit jobs, when all traffic signal work is completed. This will include all work at signalized intersections including loop replacements, adjusting existing traffic signals or any relocation work including handholes. The project engineer or district permit agent will notify the Division of Traffic Engineering and the Borough of Naugatuck to coordinate a field inspection of all work. Refer to Section 10.00 – General Clauses for Highway Illumination and Traffic Signal Projects, Article 10.00.10 and corresponding special provision.

### **Article 1.08.04 - Limitation of Operations - Add the following:**

In order to provide for traffic operations as outlined in the Special Provision "Maintenance and Protection of Traffic," the Contractor will not be permitted to perform any work which will interfere with the described traffic operations on all project roadways as follows:

#### ***Rubber Avenue, Hoadley Street, and Melbourne Street***

On the following State observed Legal Holidays:

New Year's Day  
Good Friday, Easter  
Memorial Day  
Independence Day  
Labor Day  
Thanksgiving Day  
Christmas Day

The following restrictions also apply:

On the day before and the day after any of the above Legal Holidays.

During all other times

The Contractor will not be allowed to perform any work between 6:00 p.m. and 7:00 a.m. Monday-Saturday, at any time on Sunday, or on official state holidays, except as approved by the Engineer.

**Additional Lane Closure Restrictions**

The field installation of a signing pattern shall constitute interference with existing traffic operations and shall not be allowed except during the allowable periods.

The Contractor's work schedule should be coordinated on a daily basis with, at a minimum, the Borough of Naugatuck inspection personnel, local police and fire departments, and Borough of Naugatuck Highways and Engineering. The Contractor's work schedule shall be made available, on a weekly basis, to other impacted road users and local officials, such as: local elected officials, public works personnel, emergency service providers, hospitals, public transit providers, Board of Education transportation coordinators, US Postal Service, etc.

The Contractor must submit any revisions to the proposed traffic control plans or any other traffic related changes to the Borough of Naugatuck's Town Engineer for review and approval at least 30 days prior to implementation.

The Contractor's construction equipment shall not obstruct sight lines of the motorists at intersecting roadways and driveways. If this condition cannot be attained in specific locations, a Traffic person shall be utilized.

## **SECTION 2.86 - DRAINAGE TRENCH EXCAVATION, ROCK IN DRAINAGE TRENCH EXCAVATION**

### **2.86.01—Description**

### **2.86.03—Construction Methods**

### **2.86.04—Method of Measurement**

### **2.86.05—Basis of Payment**

**2.86.01—Description:** Drainage trench excavation consists of the excavation necessary for the proper installation of drainage structures, pipes, pipe ends and any other incidental drainage items.

It shall include earth and rock excavation, removal of existing pipes, dewatering, backfill, and disposal of materials; to the trench limits described herein, to the dimensions shown on the plans, or as directed by the Engineer.

#### **Classifications:**

- (1) **Drainage Trench Excavation** will include only the excavation necessary for the construction of the drainage items and the removals specified above.
- (2) **Rock in Drainage Trench Excavation**, insofar as it applies to drainage trench excavation, shall be defined as **1/2 cubic yard or more** in volume of the following obstructions removed from the limits of the drainage trench:
  - (a) rock in definite ledge formation
  - (b) boulders, or portions of boulders
  - (c) cement masonry structures
  - (d) concrete or reinforced concrete structures
  - (e) reinforced concrete pipe
  - (f) subsurface concrete pavement or concrete base

The removal shall be as indicated or directed from within the limits defined in 2.86.03 for drainage trench excavation.

### **2.86.03—Construction Methods:**

#### **(1) Drainage Trench Excavation Limits:**

*Horizontal Limits:* Trench widths for pipes, pipe ends, pipe-arches, and drainage structures shall be as follows:

- (a) 2 feet greater than the nominal inside diameter of circular pipe or nominal inside span of elliptical pipe or pipe-arch for such diameters or spans of less than 30 inches
- (b) 3 feet greater than the nominal inside diameter of circular pipe or the nominal inside span of elliptical pipe or pipe-arch for such diameters or spans that are 30 inches or greater
- (c) 4 feet greater than the nominal inside diameter or nominal horizontal inside span for pipe-arches fabricated from structural plates
- (d) 2 feet beyond the neat lines of all exterior or foundation walls of drainage structures

*Vertical Limits:* Trench depths shall extend vertically as follows:

- (a) From the bottom of the trench to the bottom of the roadway excavation, or in areas away from roadway excavation, to the top of existing ground surface.



(b) Where drainage pipe is to be laid in a fill area, the embankment shall be placed and compacted to a minimum elevation 12 inches above the top of the proposed pipe, whereupon the drainage trench excavation shall be performed and the pipe installed.

- (2) **Drainage Trench Excavation:** Drainage trench excavation shall be made in conformity with the requirements of the plans, or as directed by the Engineer. The Contractor shall furnish and employ such shores, braces, pumps, or ancillary equipment as needed for the proper protection of property, proper completion of the work, as well as safety of the public and employees of both the Contractor and the Department. All bracing and shoring shall be removed when no longer required for the construction or safety of the work. When required, the Contractor shall provide or have on the Site at all times any OSHA certification for equipment to be used, per 1.07.07. For support of trenches greater than 10 feet in depth, working drawings shall be submitted, in accordance with 1.05.02. The Contractor shall control erosion and sedimentation at trench locations and ensure that pumped water from the drainage excavation is discharged in accordance with the requirements of 1.10.

Where a firm foundation is not encountered at the grades established due to unsuitable material, such as soft, spongy, or unstable soil, the unsuitable material shall be removed and replaced with approved backfill, thoroughly compacted in lifts not to exceed 6 inches, for the full trench width. The Engineer shall be notified prior to removal of the unsuitable material in order to determine the depth of removal necessary.

After the excavation is complete, the Contractor shall notify the Engineer and no drainage structure or material shall be placed in the excavated area until the Engineer has approved the depth of excavation and the character of the foundation material.

- (3) **Rock in Drainage Trench Excavation:**

(a) Rock in Drainage Trench Excavation - Ledge: When rock in definite ledge form is encountered, the Contractor shall excavate a minimum of 12 inches below the bottom of the proposed pipe or drainage structure; and this depth shall be filled with bedding material (as specified in M.08.03-1) below the proposed pipe; or granular fill (as specified in M.02.01) below the proposed drainage structure, which shall be thoroughly compacted in lifts not to exceed 6 inches.

(b) Rock in Drainage Trench Excavation - Boulders: When boulders are encountered, the Contractor shall remove them from the trench and if backfill is required, the void shall be filled with bedding material, surplus excavated material (as specified in 2.02.03-8) or granular fill which shall be thoroughly compacted in lifts not to exceed 6 inches.

(c) Rock in Drainage Trench Excavation –Structures: When cement masonry, concrete or reinforced concrete structures are encountered within the drainage trench limits, the Contractor shall remove the structure in its entirety or as directed by the Engineer, and if backfill is required, the void shall be filled with bedding material, surplus excavated material or granular fill which shall be thoroughly compacted in lifts not to exceed 6 inches.

- (4) **Backfill:** Suitable material excavated from the drainage trench shall be used as backfill material prior to consideration of using any other source of backfill. Backfill material used shall be of a quality satisfactory to the Engineer and shall be free from large or frozen lumps, wood and other extraneous material. Rock fill or stones larger than 5 inches shall not be placed within 1 foot of the drainage structure or pipe. The grading shall be

completed to the lines shown on the plans, or as ordered, by refilling to the required elevation with approved material, placed in layers not to exceed 6 inches in depth after compaction, which shall be thoroughly compacted with equipment approved by the Engineer.

All surplus or unsuitable material shall be removed and disposed of as directed. Should additional material be required for backfilling, it may be obtained from the Project surplus excavation in accordance with 2.02.03-8 or from borrow pits, gravel pits, or elsewhere as directed by the Engineer.

#### **2.86.04—Method of Measurement:**

**Drainage Trench Excavation:** Drainage trench excavation will not be measured for payment.

If granular fill or borrow is required to replace unsuitable material it will be measured for payment as directed by the Engineer.

**Rock in Drainage Trench Excavation:** If any material meeting the definition of Rock in Drainage Trench Excavation is encountered, the Contractor shall strip it of sufficient overlying material to allow for proper measurement and shall then notify the Engineer that the rock surface is ready for measurement. If the Contractor fails to give such notice, the Engineer will presume that the measurements taken at the time the Engineer first saw the material in question will give the true quantity of excavation.

Rock in Drainage Trench Excavation will be measured according to the classification provided in 2.86.01 and within the drainage trench excavation limits provided in 2.86.03.

For the removal of underground obstructions, as classified in 2.86.01-2, the measurement shall be the actual volume of rock removed (1/2 cubic yard or more) as approved by the Engineer.

Rock in Drainage Trench Excavation will not be measured for payment in fills.

Bedding Material or other suitable fill, as specified in 2.86.03(3), used to fill voids after rock is excavated will not be measured for payment.

#### **2.86.05—Basis of Payment:**

**Drainage Trench Excavation:** There will be no direct payment for drainage trench excavation required for the installation of drainage pipes, pipe ends, catch basins, drop inlets, manholes, and other drainage structures, or any other incidental drainage work including materials, tools, equipment and labor necessary to complete the drainage trench excavation in conformity with the plans or as directed by the Engineer.

There will be no direct payment for backfill or disposal of surplus material necessary for the satisfactory completion of this work.

There will be no direct payment made for shoring, bracing, dewatering, or for material or equipment necessary for the satisfactory completion of the work.

Where called for on the plans to install temporary earth retaining systems for the support of existing facilities, pavement, utilities, or for other constraints, payment will be made in accordance with such items in the Contract.

If granular fill or borrow is used to replace unsuitable material, payment will be made at the respective Contract unit prices, or in the absence of such items in the Contract, as Extra Work in accordance with 1.04.05.

**Rock in Drainage Trench Excavation:** When rock, conforming to the description in 2.86.01 is encountered within the limits of drainage trench excavation, its removal will be classified and

paid for at the Contract unit price per cubic yard for "Rock in Drainage Trench Excavation 0' – 10' Deep," or "Rock in Drainage Trench Excavation 0' – 20' Deep," as the case may be.

Those portions of drainage trench excavation classified and paid for as "Rock in Drainage Trench Excavation" of the various depths will be the actual volumes of rock excavated within the limits for drainage trench excavation, at the applicable bottom depth price.

Where no item or items for "Rock in Drainage Trench Excavation" at the applicable depth appear in the proposal and rock is encountered in drainage trench excavation, its removal will be paid for as Extra Work in accordance with 1.04.05.

When excavation is necessary in fill, no such excavation will be paid for as "Rock in Drainage Trench Excavation."

**When excavation is necessary for any purpose other than drainage-related items, no such excavation will be paid under this item.**

Bedding material or any other suitable material used to fill voids vacated by excavated rock will not be paid for but shall be included in the unit price per cubic yard for "Rock in Drainage Trench Excavation."

Pay Item	Pay Unit
Rock in Drainage Trench Excavation 0' - 10' Deep	c.y.
Rock in Drainage Trench Excavation 0' - 20' Deep	c.y.

## **SECTION 4.06 - BITUMINOUS CONCRETE**

Section 4.06 is being deleted in its entirety and replaced with the following:

### **4.06.01—Description**

### **4.06.02—Materials**

### **4.06.03—Construction Methods**

### **4.06.04—Method of Measurement**

### **4.06.05—Basis of Payment**

**4.06.01—Description:** Work under this section shall include the production, delivery, placement, and compaction of an uniform textured, non-segregated, smooth bituminous concrete pavement to the grade and cross section shown on the plans.

The terms listed below as used in this specification are defined as:

Bituminous Concrete: A composite material consisting of prescribed amounts of asphalt binder, and aggregates. Asphalt binder may also contain additives engineered to modify specific properties and/or behavior of the composite material. References to bituminous concrete apply to all of its forms, such as those identified as hot-mix asphalt (HMA), or polymer-modified asphalt (PMA).

Bituminous Concrete Plant (Plant): A structure where aggregates and asphalt binder are combined in a controlled fashion into a bituminous concrete mixture suitable for forming pavements and other paved surfaces.

Course: A continuous layer (a lift or multiple lifts) of the same bituminous concrete mixture placed as part of the pavement structure.

Density Lot: The total tonnage of all bituminous concrete placed in a single lift and as defined in Article 4.06.03.

Disintegration: Erosion or fragmentation of the pavement surface which can be described as polishing, weathering-oxidizing, scaling, spalling, raveling, or formation of potholes.

Dispute Resolution: A procedure used to resolve conflicts between the Engineer and the Contractor's test results that may affect payment.

Hot Mix Asphalt (HMA): A bituminous concrete mixture typically produced at 325°F.

Job Mix Formula (JMF): A recommended aggregate gradation and asphalt binder content to achieve the required mixture properties.

Lift: An application of a bituminous concrete mixture placed and compacted to a specified thickness in a single paver pass.

Percent Within Limits (PWL): The percentage of the lot falling between the Upper Specification Limit (USL) and the Lower Specification Limit (LSL).

Polymer-Modified Asphalt (PMA): A bituminous concrete mixture containing a polymer modified asphalt binder and using a qualified warm mix technology.

Production Lot: The total tonnage of a bituminous concrete mixture from a single source that may receive an adjustment.

Production Sub Lot: Portion of the production lot typically represented by a single sample.

Quality Assurance (QA): All those planned and systematic actions necessary to provide ConnDOT the confidence that a Contractor will perform the work as specified in the Contract.

Quality Control (QC): The sum total of activities performed by the vendor (Producer, Manufacturer, and Contractor) to ensure that a product meets contract specification requirements.

Superpave: A bituminous concrete mix design used in mixtures designated as “S\*” Where “S” indicates Superpave and \* indicates the sieve related to the nominal maximum aggregate size of the mix.

Segregation: A non-uniform distribution of a bituminous concrete mixture in terms of gradation, temperature, or volumetric properties.

Warm Mix Asphalt (WMA) Technology: A qualified additive or technology that may be used to produce a bituminous concrete at reduced temperatures and/or increase workability of the mixture.

**4.06.02—Materials:** All materials shall conform to the requirements of Section M.04.

**1. Materials Supply:** The bituminous concrete mixture must be from one source of supply and originate from one Plant unless authorized by the Engineer.

**2. Recycled Materials:** Reclaimed Asphalt Pavement (RAP), Crushed Recycled Container Glass (CRCG), Recycled Asphalt Shingles (RAS), or crumb rubber (CR) from recycled tires may be incorporated in bituminous concrete mixtures in accordance with Project Specifications.

**4.06.03—Construction Methods:**

**1. Material Documentation:** All vendors producing bituminous concrete must have Plants with automated vehicle-weighing scales, storage scales, and material feeds capable of producing a delivery ticket containing the information below.

- a. “State of Connecticut” printed on ticket.
- b. Name of producer, identification of Plant, and specific storage silo if used.

- c. Date and time.
- d. Mixture Designation; Mix type and level Curb mixtures for machine-placed curbing must state "curb mix only".
- e. If WMA Technology is used, the additive name and dosage rate or water injection rate must be listed.
- f. Net weight of mixture loaded into the vehicle (When RAP and/or RAS is used the moisture content shall be excluded from mixture net weight).
- g. Gross weight (equal to the net weight plus the tare weight or the loaded scale weight).
- h. Tare weight of vehicle (Daily scale weight of the empty vehicle).
- i. Project number, purchase order number, name of Contractor (if Contractor other than Producer).
- j. Vehicle number - unique means of identification vehicle.
- k. For Batch Plants, individual aggregate, recycled materials, and virgin asphalt max/target/min weights when silos are not used.
- l. For every mixture designation the running daily total delivered and sequential load number.

The net weight of mixture loaded into the vehicle must be equal to the cumulative measured weights of its components.

The Contractor must notify the Engineer immediately if, during production, there is a malfunction of the weight recording system in the automated Plant. Manually written tickets containing all required information will be allowed for no more than one hour.

The State reserves the right to have an inspector present to monitor batching and /or weighing operations.

**2. Transportation of Mixture:** The mixture shall be transported in vehicles that are clean of all foreign material, excessive coating or cleaning agents, and, that have no gaps through which mixture might spill. Any material spilled during the loading or transportation process shall be quantified by re-weighing the vehicle. The Contractor shall load vehicles uniformly so that segregation is minimized. Loaded vehicles shall be tightly covered with waterproof covers acceptable to the Engineer. Mesh covers are prohibited. The cover must minimize air infiltration. Vehicles found not to be in conformance shall not be loaded.

Vehicles with loads of bituminous concrete being delivered to State projects must not exceed the statutory or permitted load limits referred to as gross vehicle weight (GVW). The Contractor shall furnish a list and allowable weights of all vehicles transporting mixture.

The State reserves the right to check the gross and tare weight of any vehicle. If the gross or tare weight varies from that shown on the delivery ticket by more than 0.4 percent, the Engineer will recalculate the net weight. The Contractor shall correct the discrepancy to the satisfaction of the Engineer.

If a vehicle delivers mixture to the project and the delivery ticket indicates that the vehicle is overweight, the load may not be rejected but a "Measured Weight Adjustment" will be taken in accordance with Article 4.06.04.

Vehicle body coating and cleaning agents must not have a deleterious effect on the mixture. The use of solvents or fuel oil, in any concentration, is prohibited for the coating of vehicle bodies.

For each delivery, the Engineer shall be provided a clear, legible copy of the delivery ticket.

**3. Paving Equipment:** The Contractor shall have the necessary paving and compaction equipment at the project site to perform the work. All equipment shall be in good working order and any equipment that is worn, defective or inadequate for performance of the work shall be repaired or replaced by the Contractor to the satisfaction of the Engineer. During the paving operation, the use of solvents or fuel oil, in any concentration, is prohibited as a release agent or cleaner on any paving equipment (i.e., rollers, pavers, transfer devices, etc.).

Refueling or cleaning of equipment is prohibited in any location on the project where fuel or solvents might come in contact with paved areas or areas to be paved. Solvents used in cleaning mechanical equipment or hand tools shall be stored off of areas paved or to be paved.

Pavers: Each paver shall have a receiving hopper with sufficient capacity to provide for a uniform spreading operation and a distribution system that places the mix uniformly, without segregation. The paver shall be equipped with and use a vibratory screed system with heaters or burners. The screed system shall be capable of producing a finished surface of the required evenness and texture without tearing, shoving, or gouging the mixture. Pavers with extendible screed units as part of the system shall have auger extensions and tunnel extenders as necessary. Automatic screed controls for grade and slope shall be used at all times unless otherwise authorized by the Engineer. The controls shall automatically adjust the screed to compensate for irregularities in the preceding course or existing base. The controls shall maintain the proper transverse slope and be readily adjustable, and shall operate from a fixed or moving reference such as a grade wire or floating beam.

Rollers: All rollers shall be self-propelled and designed for compaction of bituminous concrete. Roller types shall include steel-wheeled, pneumatic or a combination thereof. Rollers that operate in a dynamic mode shall have drums that use a vibratory or oscillatory system or combination of. Vibratory rollers shall be equipped with indicators for amplitude, frequency and speed settings/readouts to measure the impacts per foot during the compaction process. Oscillatory rollers shall be equipped with frequency indicators. Rollers can operate in the dynamic mode using the oscillatory system on concrete structures such as bridges and catch basins if at the lowest frequency setting.

Pneumatic tire rollers shall be equipped with wide-tread compaction tires capable of exerting an average contact pressure from 60 to 90 pounds per square inch uniformly over the surface, The Contractor shall furnish documentation to the Engineer regarding tire size; pressure and loading to confirm that the proper contact pressure is being developed and that the loading and contact pressure is uniform for all wheels.

**Lighting:** For paving operations, which will be performed during hours of darkness, the paving equipment shall be equipped with lighting fixtures as described below, or with an approved equal. Lighting shall minimize glare to passing traffic. The lighting options and minimum number of fixtures are listed in Tables 4.06-1 and 4.06-2:

**TABLE 4.06-1: Minimum Paver Lighting**

Option	Fixture Configuration	Fixture Quantity	Requirement
1	Type A	3	Mount over screed area
	Type B (narrow) or Type C (spot)	2	Aim to auger and guideline
	Type B (wide) or Type C (flood)	2	Aim 25 feet behind paving machine
2	Type D Balloon	2	Mount over screed area

**TABLE 4.06-2: Minimum Roller Lighting**

Option	Fixture Configuration*	Fixture Quantity	Requirement
1	Type B (wide)	2	Aim 50 feet in front of and behind roller
	Type B (narrow)	2	Aim 100 feet in front of and behind roller
2	Type C (flood)	2	Aim 50 feet in front of and behind roller
	Type C (spot)	2	Aim 100 feet in front of and behind roller
3	Type D Balloon	1	Mount above the roller

\*All fixtures shall be mounted above the roller.

Type A: Fluorescent fixture shall be heavy-duty industrial type. Each fixture shall have a minimum output of 8,000 lumens. The fixtures shall be mounted horizontally, and be designed for continuous row installation.

Type B: Each floodlight fixture shall have a minimum output of 18,000 lumens.

Type C: Each fixture shall have a minimum output of 19,000 lumens.

Type D: Balloon light: Each balloon light fixture shall have a minimum output of 50,000 lumens, and emit light equally in all directions.

**Material Transfer Vehicle (MTV):** A MTV shall be used when placing a bituminous concrete surface course as indicated in the contract documents.

The MTV must be a vehicle specifically designed for the purpose of delivering the bituminous concrete mixture from the delivery vehicle to the paver. The MTV must continuously remix the bituminous concrete mixture throughout the placement process.

The use of a MTV will be subject to the requirements stated in Article 1.07.05- Load Restrictions. The Engineer may limit the use of the vehicle if it is determined that the use of the MTV may



damage highway components, utilities, or bridges. The Contractor shall submit to the Engineer at time of pre-construction the following information:

- The make and model of the MTV.
- The individual axle weights and axle spacing for each piece of paving equipment (haul vehicle, MTV and paver).
- A working drawing showing the axle spacing in combination with all pieces of equipment that will comprise the paving echelon.

**4. Test Section:** The Engineer may require the Contractor to place a test section whenever the requirements of this specification or Section M.04 are not met.

The Contractor shall submit the quantity of mixture to be placed and the location of the test section for review and approval by the Engineer. The same equipment used in the construction of a passing test section shall be used throughout production.

If a test section fails to meet specifications, the Contractor shall stop production, make necessary adjustments to the job mix formula, Plant operations, or procedures for placement and compaction. The Contractor shall construct test sections, as allowed by the Engineer, until all the required specifications are met. All test sections shall also be subject to removal as set forth in Article 1.06.04.

**5. Transitions for Roadway Surface:** Transitions shall be formed at any point on the roadway where the pavement surface deviates, vertically, from the uniform longitudinal profile as specified on the plans. Whether formed by milling or by bituminous concrete mixture, all transition lengths shall conform to the criteria below unless otherwise specified.

Permanent Transitions: Defined as any gradual change in pavement elevation that remains as a permanent part of the work.

A transition shall be constructed no closer than 75 feet from either side of a bridge expansion joint or parapet. All permanent transitions, leading and trailing, shall meet the following length requirements:

- a) Posted speed limit is greater than 35 MPH: 30 feet per inch of elevation change.
- b) Posted speed limit is 35 MPH or less: 15 feet per inch of elevation change.

In areas where it is impractical to use the above described permanent transition lengths the use of a shorter permanent transition length may be permitted when approved by the Engineer.

Temporary Transitions: A temporary transition is defined as a transition that does not remain a permanent part of the work. All temporary transitions shall meet the following length requirements:

- a) Posted speed limit is greater than 50 MPH
  - (1) Leading Transitions = 15 feet per inch of vertical change (thickness)
  - (2) Trailing Transitions = 6 feet per inch of vertical change (thickness)
- b) Posted speed limit is 40, 45, or 50 MPH
  - (1) Leading and Trailing = 4 feet per inch of vertical change (thickness)
- c) Posted speed limit is 35 MPH or less
  - (1) Leading and Trailing = 3 feet per inch of vertical change (thickness)

**Note:** Any temporary transition to be in-place over the winter shutdown period or during extended periods of inactivity (more than 14 calendar days) shall conform to the greater than 50 MPH requirements shown above.

**6. Spreading and Finishing of Mixture:** Prior to the placement of the mixture, the underlying base course shall be brought to the plan grade and cross section within the allowable tolerance.

Immediately before placing a bituminous concrete lift, a uniform coating of tack coat shall be applied to all existing underlying pavement surfaces and on the exposed surface of a wedge joint. Such surfaces shall be clean and dry. Sweeping or other means acceptable to the Engineer shall be used.

The mixture shall not be placed whenever the surface is wet or frozen.

The Engineer may verify the mixture temperature by means of a probe or infrared type of thermometer. The Engineer may reject the load based on readings from a probe type thermometer and the specify temperature in the quality control plan (QCP) for placement.

Tack Coat Application: The tack coat shall be applied by a pressurized spray system that results in uniform overlapping coverage at an application rate of 0.03 to 0.05 gallons per square yard for a non-milled surface and an application rate of 0.05 to 0.07 gallons per square yard for a milled surface. For areas where both milled and un-milled surfaces occur, the tack coat shall be an application rate of 0.03 to 0.05 gallons per square yard. The Engineer must approve the equipment and the method of measurement prior to use. The material for tack coat shall not be heated in excess of 160°F and shall not be further diluted.

Tack coat shall be allowed sufficient time to break prior to any paving equipment or haul vehicles driving on it.

The Contractor may request to omit the tack coat application between bituminous concrete layers that have not been exposed to traffic and are placed during the same work shift. Requests to omit tack coat application on the exposed surface of a wedge joint will not be considered.

Placement: The mixture shall be placed and compacted to provide a smooth, dense surface with a uniform texture and no segregation at the specified thickness and dimensions indicated in the plans and specifications.

When unforeseen weather conditions prevent further placement of the mixture, the Engineer is not obligated to accept or place the bituminous concrete mixture that is in transit from the Plant.

In advance of paving, traffic control requirements shall be set up, maintained throughout placement, and shall not be removed until all associated work including density testing is completed.

The Contractor shall inspect the newly placed pavement for defects in the mixture or placement before rolling is started. Any deviation from standard crown or section shall be immediately remedied by placing additional mixture or removing surplus mixture. Such defects shall be corrected to the satisfaction of the Engineer.

Where it is impractical due to physical limitations to operate the paving equipment, the Engineer may permit the use of other methods or equipment. Where hand spreading is permitted, the mixture shall be placed by means of suitable shovels and other tools, and in a uniformly loose layer at a thickness that will result in a completed pavement meeting the designed grade and elevation.

Placement Tolerances: Each lift of bituminous concrete placed at a specified thickness shall meet the following requirements for thickness and area. Any pavement exceeding these limits shall be subject to an adjustment or removal. Lift tolerances will not relieve the Contractor from meeting the final designed grade. Lifts of specified non-uniform thickness, i.e. wedge or shim course, shall not be subject to thickness and area adjustments.

- a) Thickness- Where the average thickness of the lift exceeds that shown on the plans beyond the tolerances shown in Table 4.06-3, the Engineer will calculate the thickness adjustment in accordance with Article 4.06.04.

**TABLE 4.06-3: Thickness Tolerances**

<b>Mixture Designation</b>	<b>Lift Tolerance</b>
S1	+/- 3/8 inch
S0.25, S0.375, S0.5	+/- 1/4 inch

Where the thickness of the lift of mixture is less than that shown on the plans beyond the tolerances shown in Table 4.06-3, the Contractor, with the approval of the Engineer, shall take corrective action in accordance with this specification.

- b) Area- Where the width of the lift exceeds that shown on the plans by more than the specified thickness, the Engineer will calculate the area adjustment in accordance with Article 4.06.04.
- c) Delivered Weight of Mixture - When the delivery ticket shows that the vehicle exceeds the allowable gross weight for the vehicle type, the Engineer will calculate the weight adjustment in accordance with Article 4.06.04.

Transverse Joints: All transverse joints shall be formed by saw-cutting to expose the full thickness of the lift. Tack coat shall be applied to the sawn face immediately prior to additional mixture being placed.

Compaction: The Contractor shall compact the mixture to meet the density requirements as stated in Article 4.06.03 and eliminate all roller marks without displacement, shoving, cracking, or aggregate breakage.

When placing a lift with a specified thickness less than one and one-half (1 ½) inches, or a wedge course, the Contractor shall provide a minimum rolling pattern as determined by the development of a compaction curve. The procedure to be used shall be documented in the Contractor's QCP for placement and demonstrated on the first day of placement.

The use of the vibratory system on concrete structures is prohibited. When approved by the Engineer, the Contractor may operate a roller using an oscillatory system at the lowest frequency setting.

If the Engineer determines that the use of compaction equipment in the dynamic mode may damage highway components, utilities, or adjacent property, the Contractor shall provide alternate compaction equipment. The Engineer may allow the Contractor to operate rollers in the dynamic mode using the oscillatory system at the lowest frequency setting.

Rollers operating in the dynamic mode shall be shut off when changing directions.

These allowances will not relieve the Contractor from meeting pavement compaction requirements.

Surface Requirements:

Each lift of the surface course shall not vary more than ¼ inch from a Contractor-supplied 10 foot straightedge. For all other lifts, the tolerance shall be ⅜ inch. Such tolerance will apply to all paved areas.

Any surface that exhibits these characteristics or exceeds these tolerances shall be corrected by the Contractor at its own expense.

**7. Longitudinal Joint Construction Methods:** The Contractor shall use Method I- Notched Wedge Joint (see Figure 4.06-1) when constructing longitudinal joints where lift thicknesses are between 1½ and 3 inches. S1.0 mixtures shall be excluded from using Method I. Method II Butt Joint (see Figure 4.06-2) shall be used for lifts less than 1½ inches or greater than or equal to 3 inches. During placement of multiple lifts, the longitudinal joint shall be constructed in such a manner that it is located at least 6 inches from the joint in the lift immediately below. The joint in the final lift shall be at the centerline or at lane lines. Each longitudinal joint shall maintain a consistent offset from the centerline of the roadway along its entire length. The difference in

elevation between the two faces of any completed longitudinal joint shall not exceed  $\frac{1}{4}$  inch in any location.

**Method I - Notched Wedge Joint:**

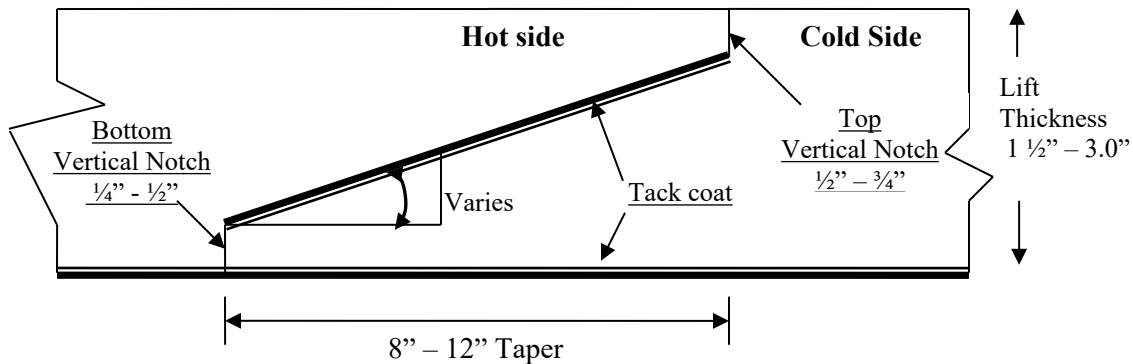

**FIGURE 4.06-1: Notched Wedge Joint**

A notched wedge joint shall be constructed as shown in Figure 4.06-1 using a device that is attached to the paver screed and is capable of independently adjusting the top and bottom vertical notches. The device shall have an integrated vibratory system.

The taper portion of the wedge joint must be placed over the longitudinal joint in the lift immediately below. The top vertical notch must be located at the centerline or lane line in the final lift. The requirement for paving full width “curb to curb” as described in Method II may be waived if addressed in the QC plan and approved by the Engineer.

The taper portion of the wedge joint shall be evenly compacted using equipment other than the paver or notch wedge joint device.

The taper portion of the wedge joint shall not be exposed to traffic for more than 5 calendar days.

Any exposed wedge joint must be located to allow for the free draining of water from the road surface.

The Engineer reserves the right to define the paving limits when using a wedge joint that will be exposed to traffic.

If Method I, Notched Wedge Joint cannot be used on lifts between 1.5 and 3 inches, Method III Butt Joint may be substituted according to the requirements below for “Method III – Butt Joint with Hot Pour Rubberized Asphalt Treatment.”

**Method II - Butt Joint:**

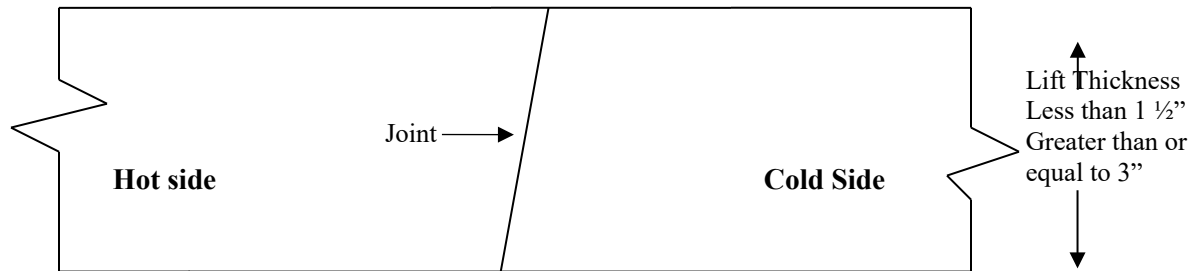
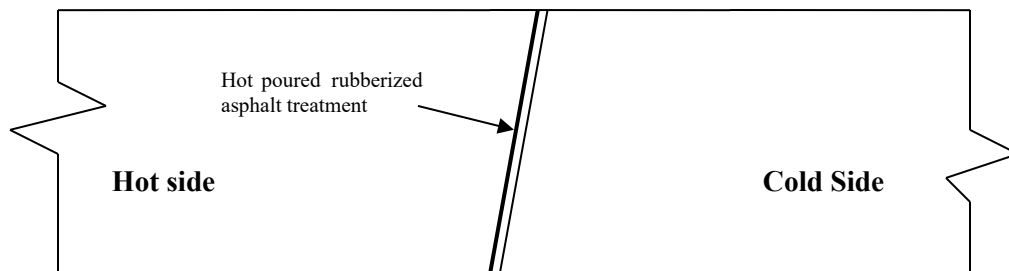

**FIGURE 4.06-2: Butt Joint**

When adjoining passes are placed, the Contractor shall utilize equipment that creates a near vertical edge (refer to Figure 4.06-2). The completing pass (hot side) shall have sufficient mixture so that the compacted thickness is not less than the previous pass (cold side). The end gate on the paver should be set so there is an overlap onto the cold side of the joint.

The Contractor shall not allow any butt joint to be incomplete at the end of a work shift unless otherwise allowed by the Engineer. When using this method, the Contractor is not allowed to leave a vertical edge exposed at the end of a work shift and must complete paving of the roadway full width “curb to curb.”

**Method III- Butt Joint with Hot Poured Rubberized Asphalt Treatment:** If Method I Wedge Joint cannot be used due to physical constraints in certain limited locations; the contractor may submit a request in writing for approval by the Engineer, to utilize Method III Butt Joint as a substitution in those locations. There shall be no additional measurement or payment made when the Method III Butt Joint is substituted for the Method I Notched Wedge Joint. When required by the contract or approved by the Engineer, Method III (see Figure 4.06-3) shall be used.



**FIGURE 4.06-3: Butt Joint with Hot Poured Rubberized Asphalt Treatment**

All of the requirements of Method II must be met with Method III. In addition, the longitudinal vertical edge must be treated with a rubberized joint seal material meeting the requirements of ASTM D 6690, Type 2. The joint sealant shall be placed on the face of the “cold side” of the butt joint as shown above prior to placing the “hot side” of the butt joint. The joint seal material shall be applied in accordance with the manufacturer’s recommendation so as to provide a uniform coverage and avoid excess bleeding onto the newly placed pavement.

**8. Contractor Quality Control (QC) Requirements:** The Contractor shall be responsible for maintaining adequate quality control procedures throughout the production and placement operations. Therefore, the Contractor must ensure that the materials, mixture and work provided by Subcontractors, Suppliers and Producers also meet contract specification requirements.

This effort must be documented in Quality Control Plans and address the actions, inspection, or sampling and testing necessary to keep the production and placement operations in control, to determine when an operation has gone out of control and to respond to correct the situation in a timely fashion.

The Standard QCP for production shall consist of the quality control program specific to the production facility.

There are three components to the QCP for placement: a Standard QCP, a Project Summary Sheet that details project specific information, and if applicable a separate Extended Season Paving Plan as required in Section 9 “Temperature and Seasonal Requirements”.

The Standard QCP for both production and placement shall be submitted to the Department for approval each calendar year and at a minimum of 30 days prior to production or placement.

Production or placement shall not occur until all QCP components have been approved by the Engineer.

Each QCP shall include the name and qualifications of a Quality Control Manager (QCM). The QCM shall be responsible for the administration of the QCP, and any modifications that may become necessary. The QCM shall have the ability to direct all Contractor personnel on the project during paving operations. All Contractor sampling, inspection and test reports shall be reviewed and signed by the QCM prior to submittal to the Engineer. The QCPs shall also include the name and qualifications of any outside testing laboratory performing any QC functions on behalf of the Contractor.

Approval of the QCP does not relieve the Contractor of its responsibility to comply with the project specifications. The Contractor may modify the QCPs as work progresses and must document the changes in writing prior to resuming operations. These changes include but are not limited to changes in quality control procedures or personnel. The Department reserves the right to deny significant changes to the QCPs.

QCP for Production: Refer to Section M.04.03-1.

QCP for Placement: The Standard QCP, Project Summary Sheet, and Extended Season Paving Plan shall conform to the format provided by the Engineer. The format is available at [http://www.ct.gov/dot/lib/dot/documents/dconstruction/pat/qcp\\_outline\\_hma\\_placement.pdf](http://www.ct.gov/dot/lib/dot/documents/dconstruction/pat/qcp_outline_hma_placement.pdf).

The Contractor shall perform all quality control sampling and testing, provide inspection, and exercise management control to ensure that placement conforms to the requirements as outlined in its QCP during all phases of the work. The Contractor shall document these activities for each day of placement.

The Contractor shall submit complete field density testing and inspection records to the Engineer within 48 hours in a manner acceptable to the Engineer.

The Contractor may obtain one (1) mat core and one (1) joint core per day for process control, provided this process is detailed in the QCP. The results of these process control cores shall not be used to dispute the Department determinations from the acceptance cores. The Contractor shall submit the location of each process control core to the Engineer for approval prior to taking the core. The core holes shall be filled to the same requirements described in sub-article 4.06.03-10.

**9. Temperature and Seasonal Requirements:** Paving, including placement of temporary pavements, shall be divided into two seasons, “In-Season” and “Extended-Season”. In-Season paving occurs from May 1 – October 14, and Extended Season paving occurs from October 15- April 30. The following requirements shall apply unless otherwise authorized or directed by the Engineer:

- Mixtures shall not be placed when the air or sub base temperature is less than 40°F regardless of the season.
- Should paving operations be scheduled during the Extended Season, the Contractor must submit an Extended Season Paving Plan for the project that addresses minimum delivered mix temperature considering WMA, PMA or other additives, maximum paver speed, enhanced rolling patterns and the method to balance mixture delivery and placement operations. Paving during Extended Season shall not commence until the Engineer has approved the plan.

**10. Obtaining Bituminous Concrete Cores:** This Section describes the methodology and sampling frequency the Contractor shall use to obtain pavement cores.

Coring shall be performed on each lift specified to a thickness of one and one-half (1 ½) inches or more within 5 days of placement. The Contractor shall extract cores (4 or 6 inch diameter for S0.25, S0.375 and S0.5 mixtures 6 inch diameter for S1.0 mixtures) from locations determined by the Engineer. The Engineer must witness the extraction, labeling of cores and filling of the core holes.

A density lot will be complete when the full designed paving width and length of the lot has been placed and shall include all longitudinal joints between the curb lines. HMA S1 mixes are excluded from the longitudinal joint density requirements.



A standard density lot is the quantity of material placed within the defined area exclusive of any structures. A combo density lot is the quantity of material placed within the defined area inclusive of structures less than or equal to 500 feet long. A bridge density lot is the quantity of material placed on a structure larger than 500 feet in length.

Prior to paving, the type and number of lot (s) shall be determined by the Engineer. The number of cores per lot shall be determined in accordance to Tables 4.06-4, 4.06-5A and 4.06-5B. Noncontiguous areas such as highway ramps may be combined to create one lot. Combined areas should be set up to target a 2000 ton lot size. The longitudinal locations of mat cores within a lot containing multiple paving passes will be determined using the total distance covered by the paver. The locations of the joint cores will be determined using the total length of longitudinal joints within the lot.

Sampling is in accordance with the following tables:

**TABLE 4.06-4: Bridge Density Lot(s)**

Length of Each Structure (Feet)	No. of Mat Cores	No. of Joint Cores
≤ 500'	See Table 4.06-5(A or B)	See Table 4.06-5(A or B)
501' – 1500'	3	3
1501' – 2500'	4	4
2501' and greater	5	5

All material placed on structures less than or equal to 500 feet in length shall be included as part of a standard lot as follows:

**TABLE 4.06-5A: Standard and Combo Density Lot(s) ≥ 500 Tons**

Lot Type	No. of Mat Cores		No. of Joint Cores		Target Lot Size (Tons)
Standard Lot / Without Bridge (s)	4		4		2000
Combo Lot / Lot With Bridge(s) <sup>(1)</sup>	4 plus	1 per structure (≤ 300')	4 plus	1 per structure (≤ 300')	2000
		2 per structure (301' – 500')		2 per structure (301' – 500')	

**TABLE 4.06-5B: Standard and Combo Density Lot < 500 Tons**

Lot Type	No. of Mat Cores		No. of Joint Cores	
Standard Lot / Without Bridge (s)	3		3	
Combo Lot / Lot With Bridge(s) <sup>(1)</sup>	2 plus	1 per structure	2 plus	1 per structure

Note:

(1) If a combo lot mat or joint core location randomly falls on a structure, the core is to be obtained on the structure in addition to the core(s) required on the structure.

After the lift has been compacted and cooled, the Contractor shall cut cores to a depth equal to or greater than the lift thickness and remove them without damaging the lift(s) to be tested. Any core that is damaged or obviously defective while being obtained will be replaced with a new core from a location within 2 feet measured in a longitudinal direction.

A mat core shall not be located any closer than one foot from the edge of a paver pass. If a random number locates a core less than one foot from any edge, the location will be adjusted by the Engineer so that the outer edge of the core is one foot from the edge of the paver pass.

Method I, Notched Wedge Joint cores shall be taken so that the center of the core is 5 inches from the visible joint on the hot mat side (Figure 4.06-5).

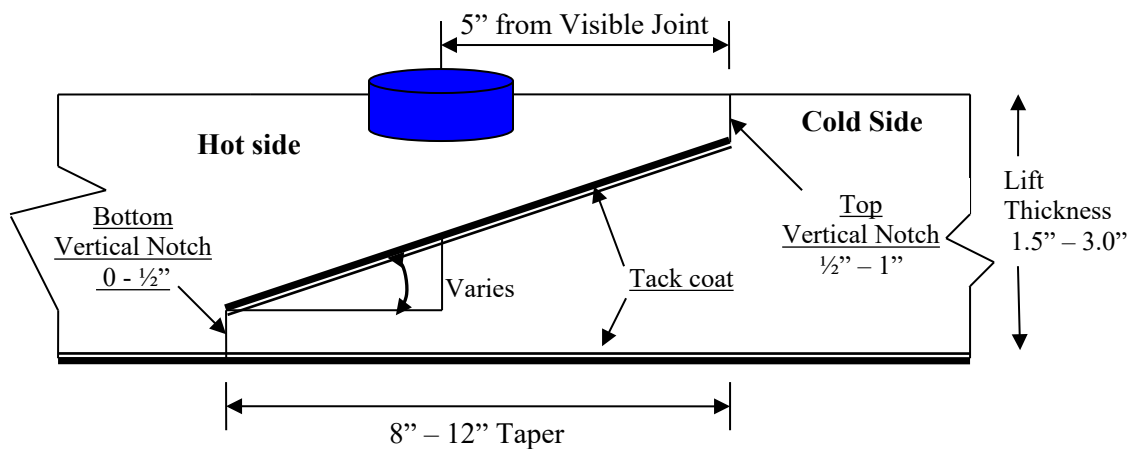

**FIGURE 4.06-5: Notched Wedge Joint Cores**

When Method II or Method III Butt Joint is utilized, cores shall be taken from the hot side so the edge of the core is within 1 inch of the longitudinal joint.

The cores shall be labeled by the Contractor with the project number, date placed, lot number and sub-lot number. The core's label shall include "M" for a mat core and "J" for a joint core. A mat core from the second lot and first sub-lot shall be labeled "M2 - 1" (Figure 4.06-4). The Engineer shall fill out a MAT-109 to accompany the cores. The Contractor shall deliver the cores and MAT-109 to the Department's Central Lab. The Contractor shall use a container approved by the Engineer. The container shall have a lid capable of being locked shut and tamper proof. The Contractor shall use foam, bubble wrap, or another suitable material to prevent the cores from being damaged during handling and transportation. Once the cores and MAT-109 are in the container the Engineer will secure the lid using a security seal. The security seal's identification number must be documented on the MAT-109. Central Lab personnel will break the security seal and take possession of the cores.

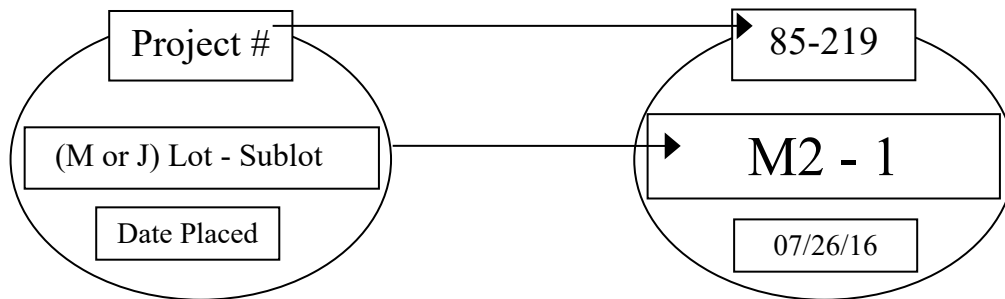

**FIGURE 4.06-4: Labeling of Cores**

Each core hole shall be filled within four hours upon core extraction. Prior to being filled, the hole shall be prepared by removing any free water and applying tack coat using a brush or other means to uniformly cover the cut surface. The core hole shall be filled using a bituminous concrete mixture at a minimum temperature of 240°F containing the same or smaller nominal maximum aggregate size and compacted with a hand compactor or other mechanical means to the maximum compaction possible. The bituminous concrete shall be compacted to 1/8 inch above the finished pavement.

**11. Acceptance Sampling and Testing:** Sampling and testing shall be performed at a frequency not less than the minimum frequency specified in Section M.04 and sub-article 4.06.03-10.

Sampling shall be performed in accordance with ASTM D 3665, or a statistically based procedure of stratified random sampling approved by the Engineer.

Plant Material Acceptance: The Contractor shall provide the required sampling and testing during all phases of the work in accordance with Section M.04. The Department will verify the Contractor's acceptance test results. Should any test results exceed the specified tolerances in the Department's current QA Program for Materials, the Contractor test results for a subject lot or sub lot may be replaced with the Department's results for the purpose of calculating adjustments. The verification procedure is included in the Department's current QA Program for Materials.

Density Acceptance: The Engineer will perform all acceptance testing in accordance with AASHTO T 331. The density of each core will be determined using the daily production's average maximum theoretical specific gravity (Gmm) established during the testing of the parent material at the Plant. When there was no testing of the parent material or any Gmm exceeds the specified tolerances in the Department's current QA Program for Materials, the Engineer will determine the maximum theoretical density value to be used for density calculations.

**12. Density Dispute Resolution Process:** The Contractor and Engineer will work in partnership to avoid potential conflicts and to resolve any differences that may arise during quality control or

acceptance testing for density. Both parties will review their sampling and testing procedures and results and share their findings. If the Contractor disputes the Engineer's test results, the Contractor must submit in writing a request to initiate the Dispute Resolution Process within 7 calendar days of the notification of the test results. No request for dispute resolution will be allowed unless the Contractor provides quality control results within the timeframe described in sub-article 4.06.03-9 supporting its position. No request for Dispute Resolution will be allowed for a Density Lot in which any core was not taken within the required 5 calendar days of placement. Should the dispute not be resolved through evaluation of existing testing data or procedures, the Engineer may authorize the Contractor to obtain a new set of core samples per disputed lot. The core samples must be extracted no later than 14 calendar days from the date of Engineer's authorization.

The number and location (mat, joint, or structure) of the cores taken for dispute resolution must reflect the number and location of the original cores. The location of each core shall be randomly located within the respective original sub lot. All such cores shall be extracted and the core hole filled using the procedure outlined in Article 4.06.03. The dispute resolution results shall be added to the original results and averaged for determining the final in-place density value.

### **13. Corrective Work Procedure:**

If pavement placed by the Contractor does not meet the specifications, and the Engineer requires its replacement or correction, the Contractor shall:

- a) Propose a corrective procedure to the Engineer for review and approval prior to any corrective work commencing. The proposal shall include:
  - Limits of pavement to be replaced or corrected, indicating stationing or other landmarks that are readily distinguishable.
  - Proposed work schedule.
  - Construction method and sequence of operations.
  - Methods of maintenance and protection of traffic.
  - Material sources.
  - Names and telephone numbers of supervising personnel.
- b) Any corrective courses placed as the final wearing surface shall match the specified lift thickness after compaction.

**14. Protection of the Work:** The Contractor shall protect all sections of the newly finished pavement from damage that may occur as a result of the Contractor's operations for the duration of the Project.

**15. Cut Bituminous Concrete Pavement:** Work under this item shall consist of making a straight-line cut in the pavement to the lines delineated on the plans or as directed by the Engineer. The cut shall provide a straight, clean, vertical face with no cracking, tearing or breakage along the cut edge.

#### 4.06.04—Method of Measurement:

**1. HMA S\* or PMA S\*:** The quantity of bituminous concrete measured for payment will be determined by the documented net weight in tons accepted by the Engineer in accordance with this specification and Section M.04.

**2. Adjustments:** Adjustments may be applied to bituminous concrete quantities and will be measured for payment using the following formulas:

**Yield Factor** for Adjustment Calculation = 0.0575 Tons/SY/inch

**Actual Area** = [(Measured Length (ft)) x (Avg. of width measurements (ft))]

**Actual Thickness (t)** = Total tons delivered / [Actual Area (SY) x 0.0575 Tons/SY/inch]

- a) Area: If the average width exceeds the allowable tolerance, an adjustment will be made using the following formula. The tolerance for width is equal to the specified thickness (in.) of the lift being placed.

**Tons Adjusted for Area (T<sub>A</sub>)** = [(L x W<sub>adj</sub>)/9] x (t) x 0.0575 Tons/SY/inch = (-) Tons

Where: L = Length (ft)

(t) = Actual thickness (inches)

W<sub>adj</sub> = (Designed width (ft) + tolerance /12) - Measured Width)

- b) Thickness: If the actual average thickness is less than the allowable tolerance, the Contractor shall submit a repair procedure to the Engineer for approval. If the actual thickness exceeds the allowable tolerance, an adjustment will be made using the following formula:

**Tons Adjusted for Thickness (T<sub>T</sub>)** = A x t<sub>adj</sub> x 0.0575 = (-) Tons

Where: A = Area = {[L x (Designed width + tolerance (lift thickness)/12)] / 9}

t<sub>adj</sub> = Adjusted thickness = [(Dt + tolerance) - Actual thickness]

Dt = Designed thickness (inches)

- c) Weight: If the quantity of bituminous concrete representing the mixture delivered to the project is in excess of the allowable gross vehicle weight (GVW) for each vehicle, an adjustment will be made using the following formula:

**Tons Adjusted for Weight (T<sub>W</sub>)** = GVW – DGW = (-) Tons

Where: DGW = Delivered gross weight as shown on the delivery ticket or measured on a certified scale.

d) Mixture Adjustment: The quantity of bituminous concrete representing the production lot at the Plant will be adjusted as follow:

i. Non-PWL Production Lot (less than 3500 tons):

The adjustment values in Table 4.06-6 and 4.06-7 shall be calculated for each sub lot based on the Air Void (AV) and Asphalt Binder Content (PB) test results for that sub lot. The total adjustment for each day's production (lot) will be computed using tables and the following formulas:

$$\text{Tons Adjusted for Superpave Design (T}_{SD}) = [(\text{AdjAV}_t + \text{AdjPB}_t) / 100] \times \text{Tons}$$

$$\text{Percent Adjustment for Air Voids} = \text{AdjAV}_t = [\text{AdjAV}_1 + \text{AdjAV}_2 + \text{AdjAV}_i + \dots + \text{AdjAV}_n] / n$$

Where:  $\text{AdjAV}_t$  = Total percent air void adjustment value for the lot

$\text{AdjAV}_i$  = Adjustment value from Table 4.06-7 resulting from each sub lot or the average of the adjustment values resulting from multiple tests within a sub lot, as approved by the Engineer.

n = number of sub lots based on Table M.04.03-2

**TABLE 4.06-6: Adjustment Values for Air Voids**

Adjustment Value (AdjAV <sub>i</sub> ) (%)	S0.25, S0.375, S0.5, S1 Air Voids (AV)
+2.5	3.8 - 4.2
+3.125*(AV-3)	3.0 - 3.7
-3.125*(AV-5)	4.3 - 5.0
20*(AV-3)	2.3 - 2.9
-20*(AV-5)	5.1 - 5.7
-20.0	≤ 2.2 or ≥ 5.8

$$\text{Percent Adjustment for Asphalt Binder} = \text{AdjPB}_t = [(\text{AdjPB}_1 + \text{AdjPB}_2 + \text{AdjPB}_i + \dots + \text{AdjPB}_n)] / n$$

Where:  $\text{AdjPB}_t$  = Total percent asphalt binder adjustment value for the lot

$\text{AdjPB}_i$  = Adjustment value from Table 4.06-7 resulting from each sub lot

n = number of binder tests in a production lot

**TABLE 4.06-7: Adjustment Values for Binder Content**

Adjustment Value (AdjAV <sub>i</sub> ) (%)	S0.25, S0.375, S0.5, S1 Pb
0.0	JMF Pb ± 0.3
- 10.0	≤ JMF Pb - 0.4 or ≥ JMF Pb + 0.4

ii. PWL Production Lot (3500 tons or more):

For each lot, the adjustment values shall be calculated based on PWL for AV, VMA and PB test results. The lot will be considered as being normally distributed and all applicable equations in AASHTO R9 and AASHTO R42 Appendix X4 will apply.

Only one test result will be considered for each sub lot. The specification limits are listed in Section M.04.

For AV, PB and voids in mineral aggregate (VMA), the individual material quality characteristic adjustment (Adj) will be calculated as follow:

For PWL between 50 and 90%:  $\text{Adj}(\text{AV}_t \text{ or } \text{PB}_t \text{ or } \text{VMA}_t) = (55 + 0.5 \text{ PWL}) - 100$

For PWL at and above 90%:  $\text{Adj}(\text{AV}_t \text{ or } \text{PB}_t \text{ or } \text{VMA}_t) = (77.5 + 0.25 \text{ PWL}) - 100$

Where:

AdjAV<sub>t</sub> = Total percent AV adjustment value for the lot

AdjPB<sub>t</sub> = Total percent PB adjustment value for the lot

AdjVMA<sub>t</sub> = Total percent VMA adjustment value for the lot

Lots with PWL less than 50% in any of the three individual material quality characteristics will be evaluated under 1.06.04.

The total adjustment for each production lot will be computed using the following formula:

**Tons Adjusted for Superpave Design (T<sub>SD</sub>)** =  $[(0.5\text{AdjAV}_t + 0.25\text{AdjPB}_t + 0.25\text{AdjVMA}_t) / 100] \times \text{Tons}$

iii. Partial Lots:

Lots with less than 4 sublots will be combined with the prior lot. If there is no prior lot with equivalent material or if the last test result of the prior lot is over 30 calendar days old, the adjustment will be calculated as indicated in 4.06.04-2.d.i.

Lots with 4 or more sublots will be calculated as indicated in 4.06.04-2.d.ii.

- e) Density Adjustment: The quantity of bituminous concrete measured for payment in a lift of pavement specified to be 1½ inches or greater may be adjusted for density. Separate density adjustments will be made for each lot and will not be combined to establish one density adjustment. The final lot quantity shall be the difference between the total payable tons for the project and the sum of the previous lots. If either the Mat or Joint adjustment value is “remove and replace”, the density lot shall be removed and replaced (curb to curb).

No positive adjustment will be applied to a Density Lot in which any core was not taken within the required 5 calendar days of placement.

**Tons Adjusted for Density ( $T_D$ )** =  $[\{(PA_M \times .50) + (PA_J \times .50)\} / 100] \times$  Density Lot Tons

Where:  $T_D$  = Total tons adjusted for density for each lot  
 $PA_M$  = Mat density percent adjustment from Table 4.06-9  
 $PA_J$  = Joint density percent adjustment from Table 4.06-10

**TABLE 4.06-9: Adjustment Values for Pavement Mat density**

Average Core Result Percent Mat Density	Percent Adjustment (Bridge and Non-Bridge) <sup>(1)(2)</sup>
97.1 - 100	-1.667*(ACRPD-98.5)
94.5 – 97.0	+2.5
93.5 – 94.4	+2.5*(ACRPD-93.5)
92.0 – 93.4	0
90.0 – 91.9	-5*(92-ACRPD)
88.0 – 89.9	-10*(91-ACRPD)
87.0 – 87.9	-30
86.9 or less	Remove and Replace (curb to curb)

**TABLE 4.06-10: Adjustment Values for Pavement Joint Density**

Average Core Result Percent Joint Density	Percent Adjustment (Bridge and Non-Bridge) <sup>(1)(2)</sup>
97.1 – 100	-1.667*(ACRPD-98.5)
93.5 – 97.0	+2.5
92.0 – 93.4	+1.667*(ACRPD-92)
91.0 – 91.9	0
89.0 – 90.9	-7.5*(91-ACRPD)
88.0 – 88.9	-15*(90-ACRPD)



87.0 – 87.9	-30
86.9 or less	Remove and Replace (curb to curb)

<sup>(1)</sup> ACRPD = Average Core Result Percent Density

<sup>(2)</sup> All Percent Adjustments to be rounded to the second decimal place. For example, 1.667 is to be rounded to 1.67.

**3. Transitions for Roadway Surface:** The installation of permanent transitions shall be measured under the appropriate item used in the formation of the transition.

The quantity of material used for the installation of temporary transitions shall be measured for payment under the appropriate item used in the formation of the transition. The installation and removal of a bond breaker, and the removal and disposal of any temporary transition formed by milling or with bituminous concrete pavement is not measured for payment.

**4. Cut Bituminous Concrete Pavement:** The quantity of bituminous concrete pavement cut will be measured in accordance with Article 2.02.04.

**5. Material for Tack Coat:** The quantity of tack coat will be measured for payment by the number of gallons furnished and applied on the Project and approved by the Engineer. No tack coat material shall be included that is placed in excess of the tolerance described in Article 4.06.03.

a. Container Method- Material furnished in a container will be measured to the nearest ½ gallon. The volume will be determined by either measuring the volume in the original container by a method approved by the Engineer or using a separate graduated container capable of measuring the volume to the nearest ½ gallon. The container in which the material is furnished must include the description of material, including lot number or batch number and manufacturer or product source.

b. Vehicle Method-

i. Measured by Weight: The number of gallons furnished will be determined by weighing the material on calibrated scales furnished by the Contractor. To convert weight to gallons, one of the following formulas will be used:

$$\text{Tack Coat (gallons at } 60^{\circ}\text{F)} = \frac{\text{Measured Weight (pounds)}}{\text{Weight per gallon at } 60^{\circ}\text{F}}$$

$$\text{Tack Coat (gallons at } 60^{\circ}\text{F)} = \frac{0.996 \times \text{Measured Weight (pounds)}}{\text{Weight per gallon at } 77^{\circ}\text{F (from test report)}}$$

ii. Measured by automated metering system on the delivery vehicle:

Tack Coat (gallons at 60°F) = Factor (from Table 4.06-11) multiplied by the measured gallons.

**TABLE 4.06-11: Factor to Convert Volume of Tack Coat to 60°F**

Tack Coat Application Temperature (°F)	Factor	Tack Coat Application Temperature (°F)	Factor
75	0.996	120	0.985
80	0.995	125	0.984
85	0.994	130	0.983
90	0.993	135	0.982
95	0.991	140	0.980
100	0.990	145	0.979
105	0.989	150	0.978
110	0.988	155	0.977
115	0.986	160	0.976

**6. Material Transfer Vehicle (MTV):** The furnishing and use of a MTV will be measured separately for payment based on the actual number of surface course tons delivered to a paver using the MTV.

**4.06.05—Basis of Payment:**

**1. HMA S\* or PMA S\*:** The furnishing and placing of bituminous concrete will be paid for at the Contract unit price per ton for “HMA S\*” or “PMA S\*”.

- All costs associated with providing illumination of the work area are included in the general cost of the work.
- All costs associated with cleaning the surface to be paved, including mechanical sweeping, are included in the general cost of the work. All costs associated with constructing longitudinal joints are included in the general cost of the work.
- All costs associated with obtaining cores for acceptance testing and dispute resolution are included in the general cost of the work.

**2. Bituminous Concrete Adjustment Costs:** The adjustment will be calculated using the formulas shown below if all of the measured adjustments in Article 4.06.04 are not equal to zero. A positive or negative adjustment will be applied to monies due the Contractor.

**Production Lot:**  $[T_T + T_A + T_W + T_{SD}] \times \text{Unit Price} = \text{Est. (P)}$

**Density Lot:**  $T_D \times \text{Unit Price} = \text{Est. (D)}$

Where: Unit Price = Contract unit price per ton per type of mixture

$T_*$  = Total tons of each adjustment calculated in Article 4.06.04

Est. ( ) = Pay Unit represented in dollars representing incentive or disincentive.

The Bituminous Concrete Adjustment Cost item if included in the bid proposal or estimate is not to be altered by the Contractor.

**3. Transitions for Roadway Surface:** The installation of permanent transitions shall be paid under the appropriate item used in the formation of the transition. The quantity of material used for the installation of temporary transitions shall be paid under the appropriate pay item used in the formation of the transition. The installation and removal of a bond breaker, and the removal and disposal of any temporary transition formed by milling or with bituminous concrete pavement is included in the general cost of the work.

4. The cutting of bituminous concrete pavement will be paid in accordance with Article 2.02.05.

5. Material for tack coat will be paid for at the Contract unit price per gallon at 60°F for "Material for Tack Coat".

6. The Material Transfer Vehicle (MTV) will be paid at the Contract unit price per ton for a "Material Transfer Vehicle".

<u>Pay Item*</u>	<u>Pay Unit*</u>
HMA S*	ton
PMA S*	ton
Bituminous Concrete Adjustment Cost	est.
Material for Tack Coat	gal.
Material Transfer Vehicle	ton

\*For contracts administered by the State of Connecticut, Department of Administrative Services, the pay items and pay units are as shown in contract award price schedule.

## **SECTION 5.86 - CATCH BASINS, MANHOLES AND DROP INLETS**

### **5.86.01—Description**

### **5.86.02—Materials**

### **5.86.03—Construction Methods**

### **5.86.04—Method of Measurement**

### **5.86.05—Basis of Payment**

**5.86.01—Description:** The work under this Section shall consist of furnishing, preparing, and installing catch basins, manholes and drop inlets (and also the removal, abandonment, alteration, reconstruction, or conversion of such existing structures) in conformity with the lines, grades, dimensions and details shown on the plans.

This Section shall also include resetting or replacing catch basin tops as well as manhole frames and covers.

**5.86.02—Materials:** The materials for this work shall meet the following requirements:

Drainage structures shall meet the requirements of M.08.02 and shall utilize concrete with a 28-day minimum compressive strength of 4000 psi.

Galvanizing shall meet the requirements of M.06.03.

Mortar shall meet the requirements of M.11.04.

Butyl rubber joint seal shall meet the requirements of ASTM C990.

Granular fill, if necessary, shall meet the requirements of M.02.01.

Protective compound material shall be a type appearing on the Department's Qualified Products List and be acceptable to the Engineer, as specified in M.03.09.

**5.86.03—Construction Methods:** Drainage trench excavation, including rock in drainage trench excavation and backfilling, shall be performed in accordance with 2.86.03 and the requirements of the plans.

Where a drainage structure is to be installed below the surface, a drainage trench shall be excavated to the required depth, the bottom of which shall be graded to the elevation of the bottom of the proposed drainage structure or to ensure a uniform foundation for the structure.

Where a firm foundation is not encountered at the grades established due to unsuitable material, such as soft, spongy, or unstable soil, the unsuitable material shall be removed and replaced with approved granular fill, thoroughly compacted in lifts not to exceed 6 inches. The Engineer shall be notified prior to removal of the unsuitable material in order to determine the depth of removal necessary.

When rock, as defined in 2.86.01-2, is encountered, work shall be performed in accordance with 2.86.03 and the requirements of the plans.

When a drainage structure outside of proposed drainage trench limits is to be removed, it shall be completely removed and all pipes shall be removed or plugged with cement masonry.

When a drainage structure is to be abandoned, the structure shall be removed to a depth 2 feet below the subgrade or as directed by the Engineer. The floor of the structure shall be broken and all pipes shall be plugged with cement masonry.

Drainage structures shall be constructed in accordance with the plans and the requirements contained herein for the character of the work involved. The provisions of 6.02.03 pertaining to bar reinforcement shall apply except that shop drawings need not be submitted for approval unless called for in the plans, Contract or directed by the Engineer. Welding shall be performed in accordance with the applicable sections of the AWS Structural Welding Code, D1.1.

When it becomes necessary to increase the horizontal dimensions of manholes, catch basins and drop inlets to sizes greater than those shown on the plans in order to provide for multiple pipe installations, large pipes or for other reasons, the Contractor shall construct such manholes, catch basins and drop inlets to modified dimensions as directed by the Engineer.

The surfaces of the tops of all catch basins, and drop inlets shall be given a coat of protective compound material, at the manufacturer's recommended application rate, immediately upon completion of the concrete curing period.

All masonry units shall be laid in full mortar beds.

Metal fittings for catch basins, manholes or drop inlets shall be set in full mortar beds or otherwise secured as shown on the plans.

All inlet and outlet pipes shall be set flush with the inside face of the wall of the drainage structure as shown on the plans. The pipes shall extend through the walls for a sufficient distance beyond the outside surface to allow for satisfactory connections, and the concrete or masonry shall be constructed around them neatly to prevent leakage along their outer surfaces.

When constructing a new drainage structure within a run of existing pipe, the section of existing pipe disturbed by the construction shall be replaced with new pipe of identical type and size extending from the drainage structure to the nearest joint of the existing pipe in accordance with 6.86.03 or as directed by the Engineer.

Backfilling shall be performed in accordance with 2.86.03.

Frames, covers and tops which are to be reset shall be removed from their present beds, the walls or sides shall be rebuilt to conform to the requirements of the new construction and the frames, covers and tops shall be reset as shown on the plans or as directed by the Engineer.

#### **5.86.04—Method of Measurement:**

**Drainage Trench Excavation:** In accordance with 2.86.04, excavation for drainage trench will not be measured for payment but shall be included in the Contract unit price for the type of structure being installed.

**Rock in Drainage Trench Excavation:** Rock in Drainage Trench Excavation will be measured in accordance with the drainage trench excavation limits described in 2.86.03.

**Manholes, Catch Basins and Drop Inlets** will be measured as separate units.

**Resetting of Manholes, Catch Basins and Drop Inlets** will be measured as separate units.

**Replacement of frames, covers, and tops** will be measured as a unit for catch basin top or manhole frame and cover.

**Conversion of drainage structures** as specified on the plans, or as directed by the Engineer, including structure reconstruction will be measured for payment as a unit.

**Removal or abandonment of drainage structures** outside of drainage trench excavation limits, as defined in 2.86.03, will be measured as separate units.

There will be no measurement or direct payment for the application of the protective compound material, the cost of this work shall be considered as included in the general cost of the work.

Measurement for payment for work and materials involved with installing pipes to connect new drainage structures into a run of existing pipe will be as provided for under the applicable Contract items in accordance with 6.86.04.

There will be no measurement or direct payment for plugging existing pipes with cement masonry, the cost of this work will be considered as included in the general cost of the work.

**5.86.05—Basis of Payment:**

**Drainage Trench Excavation** for the installation of proposed structures described herein will be paid for under the respective drainage Contract item(s) for which the excavation is being performed, in accordance with the provisions of 2.86.05.

**Rock in Drainage Trench Excavation** will be paid for in accordance with the provisions of 2.86.05.

**Manholes and Catch Basins** will be paid for at the Contract unit price for each "Manhole," or "Catch Basin," of the type specified, at "0' to 10' Deep" or "0' to 20' Deep," complete in place, which price shall include all excavation, backfill, materials, equipment, tools and labor incidental thereto.

**Drop Inlets** will be paid for at the Contract unit price for each "Drop Inlet," of the type specified, complete in place, which price shall include all excavation, backfill, materials, equipment, tools and labor incidental thereto.

**Manholes, Catch Basins and Drop Inlets** constructed to modified dimensions as directed by the Engineer, will be paid for as follows:

Where the interior floor area has to be increased to accommodate existing field conditions, as measured horizontally at the top of the base of the completed structure, and does not exceed 125% of the interior floor area as shown on the plans for that structure, then the structure shall be paid for at the Contract unit price for each "Manhole," "Catch Basin," or "Drop Inlet" of the type specified. Where the floor area is greater than 125%, the increase in the unit price for the individual structure shall be in direct proportion to the increase of the completed structure interior floor area as compared to the interior floor area as shown on the plans for that structure. Such increased unit price shall include all excavation, materials, equipment, tools, and labor incidental to the completion of the structure.

**Reset Units** will be paid for at the Contract unit price each for "Reset Manhole," "Reset Catch Basin," or "Reset Drop Inlet," of the type specified, respectively, complete in place, which price shall include excavation, cutting of pavement, removal and replacement of pavement structure, and all materials, equipment, tools and labor incidental thereto, except when the work requires reconstruction greater than 3 feet, measured vertically, then the entire cost of resetting the unit will be paid for as Extra Work in accordance with the provisions of 1.04.05.

**Frames, Covers, and Tops** when required in connection with reset units, will be paid for at the Contract unit price each for such "Manhole Frame and Cover" or "(Type) Catch Basin Top," complete in place, including all incidental expense; or when no price exists, the furnishing and placing of such material will be paid for as Extra Work in accordance with the provisions of 1.04.05.

When the catch basin top has a stone or granite curb in its design, the curb or inlet shall be included in the cost of the "(Type) Catch Basin Top."

**Conversion of drainage structures** will be paid for at the Contract unit price each for "Convert Catch Basin to (Type) Catch Basin," "Convert Catch Basin to (Type) Manhole," or "Convert

Manhole to (Type) Catch Basin," complete in place, which price shall include excavation, cutting of pavement, removal and replacement of pavement, backfill, all alterations to existing structure, all materials including catch basin frame and grate of the type specified, or manhole frame and cover, all equipment, tools and labor incidental thereto.

The maximum change in elevation of frame under these items shall not exceed 3 feet. Greater depth changes, if required, shall be paid for as Extra Work, in accordance with 1.04.05.

**Removal or abandonment of drainage structures** outside of drainage trench excavation limits as defined in 2.86.03 will be paid for at the Contract unit price each for "Remove Drainage Structure – 0' to 10' Deep," "Remove Drainage Structure – 0' to 20' Deep," or "Abandon Drainage Structure," which price shall include excavation, cutting of pavement, removal and replacement of pavement, backfill, and all equipment, tools and labor incidental thereto.

Pay Item	Pay Unit
(Type) Catch Basin – 0' to 10' Deep	ea.
(Type) Catch Basin – 0' to 20' Deep	ea.
Manhole (Size) – 0' to 10' Deep	ea.
Manhole (Size) – 0' to 20' Deep	ea.
(Type) Drop Inlet	ea.
Reset Catch Basin	ea.
Reset Manhole	ea.
Reset Drop Inlet	ea.
Convert Catch Basin to (Type) Catch Basin	ea.
Convert Catch Basin to (Type) Manhole	ea.
Convert Manhole to (Type) Catch Basin	ea.
Manhole Frame and Cover	ea.
(Type) Catch Basin Top	ea.
Remove Drainage Structure – 0' to 10' Deep	ea.
Remove Drainage Structure – 0' to 20' Deep	ea.
Abandon Drainage Structure	ea.

## **SECTION 6.86 - DRAINAGE PIPES, DRAINAGE PIPE ENDS**

### **6.86.01—Description**

### **6.86.02—Materials**

### **6.86.03—Construction Methods**

### **6.86.04—Method of Measurement**

### **6.86.05—Basis of Payment**

**6.86.01—Description:** This work shall consist of furnishing, preparing and installing drainage pipes of the size and type specified, bedding material, joint sealant, rubber gaskets, clamps, collars, grout, grout collars, drainage trench excavation, backfilling or satisfactory disposal of all materials, the removal of which is necessary for the proper completion of the work, connecting proposed drainage systems to existing systems, plugging or abandoning existing pipes and removal of existing pipe within trench limits, as shown on the plans or as directed by the Engineer.

This Section shall also include removal of drainage pipes outside of drainage trench excavation limits, as defined in 2.86.03-1.

**6.86.02—Materials:** The materials for this work shall meet the following requirements: Drainage Pipe, Drainage Pipe Ends, Sealers, Gaskets and connection hardware shall meet the requirements of M.08.01.

Bedding Material shall meet the requirements of M.08.03-1.

Granular Fill, if necessary, shall meet the requirements of M.02.01.

Brick Masonry shall meet the requirements of M.11.03 and Mortar shall meet the requirements of M.11.04.

Concrete used for Concrete Pipe Connections shall be Class “F” Concrete meeting the requirements of M.03.

### **6.86.03—Construction Methods:**

**(1) Drainage Trench Excavation:** Drainage trench excavation and backfilling shall be performed in accordance with 2.86.03 and the requirements of the plans.

Where drainage pipe is to be laid below the surface, a drainage trench shall be excavated to the required depth, the bottom of which shall be graded to the elevation of the bottom of the bedding material.

Where drainage pipe is to be laid in a fill area, the embankment shall be placed and compacted to a minimum elevation 12 inches above the top of the proposed pipe, whereupon the drainage trench excavation shall be performed and the pipe installed.

**(2) Rock in Drainage Trench Excavation:** When rock, as defined in 2.86.01-2, is encountered, work shall be performed in accordance with 2.86.03 and the requirements of the plans.

**(3) Drainage Pipe Installation:** New or re-laid drainage pipes shall be installed on 4 inches of bedding material (12 inches if over rock in ledge formation), the details as shown on the plans, or as directed by the Engineer. Prior to placement of the drainage pipe, in accordance with the plans, bedding material shall be pre-shaped to 10% of the total height



of the pipe in order to keep the pipe in the center of the trench. Following placement of the drainage pipe, bedding material backfill shall be placed in accordance with the following table:

<b>Internal Pipe Diameter</b>	<b>Required Bedding Material Backfill</b>
< 48 inches*	25% of total height of the pipe
≥ 48 inches*	12 inches above the top of the pipe
*Includes pipe arch of equivalent internal horizontal span See Standard Drawing	

The placement of the drainage pipe shall start at the downstream end and progress upstream or as shown on the plans, or as directed by the Engineer. All drainage pipes shall be carefully laid in the center of the drainage trench, true to the lines and grades given. Bell ends shall face upgrade and all joints shall be tight.

Joints in concrete pipe shall be sealed with cold-applied bituminous sealer, preformed plastic gaskets or flexible, watertight, rubber-type gaskets. Portland cement mortar shall not be used for sealing pipe joints except with permission of the Engineer.

When cold-applied bituminous sealer is used, the bell and spigot ends shall be wiped clean and dry before applying the bituminous sealer to the pipe ends. Before the drainage pipes are placed in contact with each other, the spigot or tongue end shall be completely covered with bituminous sealer; then the pipe shall be laid to line and grade so the inside surface of all abutting pipes are flush. Additional bituminous sealer shall be applied to the joint after the connection has been made to ensure a water tight connection.

Where the end of an existing drainage pipe is not compatible with the end of a proposed concrete pipe, the Contractor shall align the inner diameters of the pipes being connected, butt the pipe ends together, and construct a cast-in-place concrete pipe connection, as shown in the plans. Incompatible bell/spigot or tongue/groove ends shall be cut off as required to ensure the interior drainage pipe walls are aligned to provide a smooth transition between the pipes.

Metal pipe and pipe arches shall be carefully joined and firmly clamped together by approved connecting bands, which shall be properly bolted in place before any backfill is placed.

Newly installed drainage pipe which is not in true alignment, or which shows any settlement or distortion, shall be reinstalled in accordance with 1.05.03.

When drainage pipe outside of proposed drainage trench limits is to be removed, it shall be removed to the limits shown on the plans and all remaining pipes shall be plugged with cement masonry.

Where shown on the plans or directed by the Engineer, the Contractor shall plug abandoned existing pipes with cement masonry.

**(4) Drainage Pipe End Installation:** Reinforced concrete drainage pipe ends shall be placed on a prepared bed of the existing ground and accurately aligned as shown on the plans. The joints shall be sealed as specified in 6.86.03-3 and backfill shall be placed around both sides of the unit simultaneously to the elevation shown on the plans.

Metal drainage pipe ends shall be placed on a prepared bed of the existing ground and accurately aligned as shown on the plans. After the attachment of the drainage pipe end, backfill shall be placed around both sides of the unit up to the elevation shown on the plans, exercising caution to avoid displacement or deformation of the unit.

**6.86.04—Method of Measurement:** This work will be measured as follows:

**Drainage Trench Excavation**, in accordance with 2.86.04, will not be measured for payment.

**Rock in Drainage Trench Excavation** will be measured in accordance with 2.86.04.

**Bedding Material** will not be measured for payment.

**New and Re-laid Pipes and Pipe Arches** will be measured for payment by the actual number of linear feet of pipe or pipe arch of the various sizes and types, completed and accepted and measured in place along the invert. Coupling bands and fittings for pipes and pipe arches will not be measured for payment.

**Reinforced Concrete Drainage Pipe Ends and Metal Drainage Pipe Ends** will be measured for payment as separate units.

**Corrugated Metal Pipe Elbows** (of the Size and Type specified) will be measured for payment by the actual number of linear feet of pipe elbows completed and accepted, based on 6 linear feet per elbow, as shown on the plans. Coupling bands for elbows will not be measured for payment.

**Concrete Pipe Connection** will be measured for payment by the number of each concrete pipe connection constructed at locations where proposed concrete pipes tie into an existing pipe with an incompatible end, completed and accepted by the Engineer.

**Removal of drainage pipe** outside of drainage trench excavation limits, as defined in 2.86.03, will be measured for payment by the actual number of linear feet of drainage pipe removed.

There will be no measurement for plugging existing pipes with cement masonry.

**6.86.05—Basis of Payment:**

**Drainage Trench Excavation** for the installation of drainage pipes will not be paid separately but shall be included in the Contract unit price for the respective drainage pipe or pipe end item(s), in accordance with the provisions of 2.86.05.

**Rock in Drainage Trench Excavation** will be paid for in accordance with the provisions of 2.86.05.

**Bedding Material** necessary for the installation of drainage items described herein will be included in the Contract unit price for the respective drainage pipe or pipe end item(s). Bedding material required to fill voids when rock in drainage trench is encountered will not be measured for payment but shall be included in the Contract unit price for "Rock in Drainage Trench Excavation," in accordance with 2.86.05.

**New Pipes and Pipe Arches** will be paid for at the Contract unit price per linear foot for "(Size and Type) Pipe (Thickness) – 0' to 10' Deep," "(Size and Type) Pipe (Thickness) – 0' to 20' Deep," "(Size) Pipe Arch (Thickness) – 0' to 10' Deep" or "(Size) Pipe Arch (Thickness) – 0' to 20' Deep" complete in place, including materials, drainage trench excavation, bedding material, equipment, tools, and labor incidental thereto.

**Relaid Pipes and Pipe Arches** will be paid for at the Contract unit price per linear foot for "Relaid Pipe (Size and Type) – 0' to 10' Deep," "Re-laid Pipe (Size and Type) – 0' to 20' Deep," "Relaid Pipe Arch (Size and Type) – 0' to 10' Deep," or "Relaid Pipe Arch (Size and Type) – 0' to 20' Deep," complete in place, including all materials, drainage trench excavation, bedding material, equipment, tools, and labor incidental thereto.

**Reinforced Concrete Drainage Pipe Ends and Metal Drainage Pipe Ends** will be paid for at the Contract unit price for each drainage pipe end of the Size and Type specified, complete in place, including all excavation, materials, attachment systems, equipment, tools and labor incidental thereto.

**Corrugated Metal Pipe Elbows** will be paid for at the Contract unit price per linear foot for "(Size and Type) Corrugated Metal Pipe Elbow" including all materials, drainage trench excavation, bedding material, equipment, tools, and labor incidental thereto.

**Concrete Pipe Connection** will be paid for at the Contract unit price each for "Concrete Pipe Connection" complete in place, including all materials, equipment, tools and labor incidental thereto.

**Removal of drainage pipes** of all types and sizes, outside of drainage trench excavation limits, as defined in 2.86.03-1, will be paid for at the Contract unit price per linear foot for "Remove Existing Pipe – 0' to 10' Deep," or "Remove Existing Pipe – 0' to 20' Deep," which price shall include excavation, temporary trench protection, backfill, and all equipment, tools and labor incidental thereto.

There will be no direct payment for the plugging of existing drainage pipes, but the cost thereof shall be included in the respective drainage Contract item(s).

Pay Item	Pay Unit
(Size and Type) Pipe (Thickness) – 0' to 10' Deep	l.f.
(Size and Type) Pipe (Thickness) – 0' to 20' Deep	l.f.
(Size and Type) Pipe Arch (Thickness) – 0' to 10' Deep	l.f.
(Size and Type) Pipe Arch (Thickness) – 0' to 20' Deep	l.f.
Relaid (Size and Type) Pipe– 0' to 10' Deep	l.f.
Relaid (Size and Type) Pipe– 0' to 20' Deep	l.f.
(Size and Type) Relaid Pipe Arch – 0' to 10' Deep	l.f.
(Size and Type) Relaid Pipe Arch – 0' to 20' Deep	l.f.
(Size) Reinforced Concrete Drainage Pipe End	ea.
(Size) Metal Drainage Pipe End	ea.
(Size and Type) Corrugated Metal Pipe Elbow	l.f.
Concrete Pipe Connection	ea.
Remove Existing Pipe – 0' to 10' Deep	l.f.
Remove Existing Pipe – 0' to 20' Deep	l.f.

## **SECTION 10.00 - GENERAL CLAUSES FOR HIGHWAY ILLUMINATION AND TRAFFIC SIGNAL PROJECTS**

**Article 10.00.10 Section 3.** Functional Inspection, first paragraph after the 2<sup>nd</sup> sentence: Add the following:

The contractor shall have a bucket truck with crew on site during the Functional Inspection to make any necessary aerial signal adjustments as directed by the Engineer.

**Article 10.00.12** - Negotiations with utility company: Add the following:

The contractor shall give notice to utility companies a minimum of 30 days prior to required work or services to the utility company. Refer to Section 1.07 – Legal Relations and Responsibilities for the list of utility companies and representatives the contractor shall use.

The Contractor shall perform all work in conformance with Rules and Regulations of Public Utility Regulatory Authority (PURA) concerning Traffic Signals attached to Public Service Company Poles. The Contractor is cautioned that there may be energized wires in the vicinity of the specified installations. In addition to ensuring compliance with NESC and OSHA regulations, the Contractor and/or its Sub-Contractors shall coordinate with the appropriate utility company for securing/protecting the site during the installation of traffic signal mast arms, span poles or illumination poles.

When a span is attached to a utility pole, the Contractor shall ensure the anchor is in line with the proposed traffic signal span wire. More than 5 degree deviation will lower the holding strength and is not allowed. The Contractor shall provide any necessary assistance required by the utility company, and ensure the anchor and guy have been installed and properly tensioned prior to attaching the span wire to the utility pole.

## **SECTION M.04 BITUMINOUS CONCRETE MATERIALS**

Section M.04 is being deleted in its entirety and replaced with the following:

### **M.04.01—Bituminous Concrete Materials and Facilities**

### **M.04.02—Mix Design and Job Mix Formula (JMF)**

### **M.04.03—Production Requirements**

**M.04.01—Bituminous Concrete Materials and Facilities:** Each source of component material, Plant and laboratory used to produce and test bituminous concrete must be qualified on an annual basis by the Engineer. AASHTO or ASTM Standards noted with an (M) have been modified and are detailed in Table M.04.03-6.

Aggregates from multiple sources of supply must not be blended or stored in the same stockpile.

#### **1. Coarse Aggregate:**

All coarse aggregate shall meet the requirements listed in Section M.01.

#### **2. Fine Aggregate:**

All fine aggregate shall meet the requirements listed in Section M.01

#### **3. Mineral Filler:**

Mineral filler shall conform to the requirements of AASHTO M 17.

#### **4. Performance Graded (PG) Asphalt Binder:**

##### **a. General:**

i. PG asphalt binder shall be uniformly mixed and blended and be free of contaminants such as fuel oils and other solvents. Binder shall be properly heated and stored to prevent damage or separation.

ii. The binder shall meet the requirements of AASHTO M 332 and shall be graded or verified in accordance with AASHTO R 29. The Contractor shall submit a Certified Test Report and bill of lading representing each delivery in accordance with AASHTO R 26(M). The Certified Test Report must also indicate the binder specific gravity at 77°F; rotational viscosity at 275°F and 329°F and the mixing and compaction viscosity-temperature chart for each shipment.

iii. The Contractor shall submit the name(s) of personnel responsible for receipt, inspection, and record keeping of PG binder. Contractor plant personnel shall document specific storage tank(s) where binder will be transferred and stored until used, and provide binder samples to the Engineer upon request. The person(s) shall assure that each shipment is accompanied by a statement certifying that the transport vehicle was inspected before loading and was found acceptable for the material shipped, and, that the binder is free

of contamination from any residual material, along with two (2) copies of the bill of lading.

iv. The blending or combining of PG binders in one storage tank at the Plant from different suppliers, grades, or additive percentages is prohibited.

b. Basis of Approval:

The request for approval of the source of supply shall list the location where the material will be manufactured, and the handling and storage methods, along with necessary certification in accordance with AASHTO R 26(M). Only suppliers/refineries that have an approved “Quality Control Plan for Performance Graded Binders” formatted in accordance with AASHTO R 26(M) may supply PG binders to Department projects.

c. Standard Performance Grade (PG) Binder:

- i. Standard PG binder shall be defined as “Neat”. Neat PG binders shall be free from modification with: fillers, extenders, reinforcing agents, adhesion promoters, thermoplastic polymers, acid modification and other additives such as re-refined motor oil, and shall indicate such information on each bill of lading and certified test report.
- ii. The standard asphalt binder grade shall be PG 64S-22.

d. Modified Performance Grade (PG) Binder:

The modified asphalt binder shall be Performance Grade PG 64E-22 asphalt modified solely with a Styrene-Butadiene-Styrene (SBS) polymer. The polymer modifier shall be added at either the refinery or terminal and delivered to the bituminous concrete production facility as homogenous blend. The stability of the modified binder shall be verified in accordance with ASTM D7173 using the Dynamic Shear Rheometer (DSR). The DSR  $G^*/\sin(\delta)$  results from the top and bottom sections of the ASTM D7173 test shall not differ by more than 10%. The results of ASTM D7173 shall be included on the Certified Test Report. The binder shall meet the requirements of AASHTO M 332 (including Appendix X1) and AASHTO R 29.

e. Warm Mix Additive or Technology:

- i. The warm mix additive or technology must be listed on the North East Asphalt User Producer Group (NEAUPG) Qualified Warm Mix Asphalt (WMA) Technologies List at the time of bid, which may be accessed online at <http://www.neaupg.uconn.edu>.
- ii. The warm mix additive shall be blended with the asphalt binder in accordance with the manufacturer’s recommendations.
- iii. The blended binder shall meet the requirements of AASHTO M 332 and shall be graded or verified in accordance with AASHTO R 29 for the specified binder grade. The Contractor shall submit a Certified Test Report showing the results of the testing demonstrating the binder grade. In addition, it must include the grade of the virgin binder, the brand name of the warm mix additive, the manufacturer’s suggested rate for

the WMA additive, the water injection rate (when applicable) and the WMA Technology manufacturer's recommended mixing and compaction temperature ranges.

## **5. Emulsified Asphalts:**

### **a. General:**

- i. The emulsified asphalt shall meet the requirements of AASHTO M 140 or AASHTO M 208 as applicable.
- ii. The emulsified asphalts shall be free of contaminants such as fuel oils and other solvents.
- iii. The blending at mixing plants of emulsified asphalts from different suppliers is prohibited.

### **b. Basis of Approval**

- i. The request for approval of the source of supply shall list the location where the material is manufactured, the handling and storage methods, and certifications in accordance with AASHTO PP 71. Only suppliers that have an approved "Quality Control Plan for Emulsified Asphalt" formatted in accordance with AASHTO PP 71 and submit monthly split samples per grade to the Engineer may supply emulsified asphalt to Department projects.
- ii. Each shipment of emulsified asphalt delivered to the project site shall be accompanied with the corresponding Certified Test Report listing Saybolt viscosity, residue by evaporation, penetration of residue, and weight per gallon at 77°F and Material Certificate.
- iii. Anionic emulsified asphalts shall conform to the requirements of AASHTO M-140. Materials used for tack coat shall not be diluted and meet grade RS-1 or RS-1H. When ambient temperatures are 80°F and rising, grade SS-1 or SS-1H may be substituted if permitted by the Engineer.
- iv. Cationic emulsified asphalt shall conform to the requirements of AASHTO M-208. Materials used for tack coat shall not be diluted and meet grade CRS-1. The settlement and demulsibility test will not be performed unless deemed necessary by the Engineer. When ambient temperatures are 80°F and rising, grade CSS-1 or CSS-1H may be substituted if permitted by the Engineer.

## **6. Reclaimed Asphalt Pavement (RAP):**

- a. General: RAP is a material obtained from the cold milling or removal and processing of bituminous concrete pavement. RAP material shall be crushed to 100% passing the ½ inch sieve and free from contaminants such as joint compound, wood, plastic, and metals.
- b. Basis of Approval: The RAP material will be accepted on the basis of one of the following criteria:
  - i. When the source of all RAP material is from pavements previously constructed on Department projects, the Contractor shall provide a Materials Certificate listing the detailed locations and lengths of those pavements and that the RAP is only from those locations listed.
  - ii. When the RAP material source or quality is not known, the Contractor shall request for approval to the Engineer at least 30 calendar days prior to the start of the paving operation. The request shall include a Material Certificate and applicable test results stating that the RAP consists of aggregates that meet the specification requirements of sub articles M.04.01-1 through 3, and, that the binder in the RAP is substantially free of solvents, tars and other contaminants. The Contractor is prohibited from using unapproved material on Department projects and shall take necessary action to prevent contamination of approved RAP stockpiles. Stockpiles of unapproved material shall remain separate from all other RAP materials at all times. The request for approval shall include the following:
    - 1. A 50-pound sample of the RAP to be incorporated into the recycled mixture.
    - 2. A 25-pound sample of the extracted aggregate from the RAP.

**7. Crushed Recycled Container Glass (CRCG):**

- a. Requirements: The Contractor may propose to use clean and environmentally-acceptable CRCG in an amount not greater than 5% by weight of total aggregate.
- b. Basis of Approval: The Contractor shall submit to the Engineer a request to use CRCG. The request shall state that the CRCG contains no more than 1% by weight of contaminants such as paper, plastic and metal and conform to the following gradation:

<b>CRCG Grading Requirements</b>	
<u>Sieve Size</u>	<u>Percent Passing</u>
3/8-inch	100
No. 4	35-100
No. 200	0.0-10.0

The Contractor shall submit a Materials Certificate to the Engineer stating that the CRCG complies with all the applicable requirements in this specification.

**8. Joint Seal Material:**



- a. Requirements: Joint seal material must meet the requirements of ASTM D 6690 – Type 2. The Contractor shall submit a Material Certificate in accordance with Article 1.06.07 certifying that the joint seal material meets the requirements of this specification.

## 9. Recycled Asphalt Shingles (RAS)

- a. Requirements: RAS shall consist of processed asphalt roofing shingles from post-consumer asphalt shingles or from manufactured shingle waste. The RAS material under consideration for use in bituminous concrete mixtures must be certified as being asbestos free and shall be entirely free of whole, intact nails. The RAS material shall meet the requirements of AASHTO MP 23.

The producer shall test the RAS material to determine the asphalt content and the gradation of the RAS material. The producer shall take necessary action to prevent contamination of RAS stockpiles.

The Contractor shall submit a Materials Certificate to the Engineer stating that the RAS complies with all the applicable requirements in this specification.

## 10. Plant Requirements:

- a. General: The Plant producing bituminous concrete shall comply with AASHTO M 156.
- b. Storage Silos: The Contractor may use silos for short-term storage with the approval of the Engineer. A silo must have heated cones and an unheated silo cylinder if it does not contain a separate internal heating system. When multiple silos are filled, the Contractor shall discharge one silo at a time. Simultaneous discharge of multiple silos for the same Project is not permitted.

<u>Type of silo cylinder</u>	<u>Maximum storage time for all classes (hr)</u>	
	HMA	WMA/PMA
Open Surge	4	Mfg Recommendations*
Unheated – Non-insulated	8	Mfg Recommendations*
Unheated – Insulated	18	Mfg Recommendations*
Heated – No inert gas	TBD by the Engineer	

\*Not to exceed HMA limits

- c. Documentation System: The mixing plant documentation system shall include equipment for accurately proportioning the components of the mixture by weight and in the proper order, controlling the cycle sequence and timing the mixing operations. Recording equipment shall monitor the batching sequence of each component of the mixture and produce a printed record of these operations on each Plant ticket, as specified herein.

If recycled materials are used, the Plant tickets shall include their dry weight, percentage and daily moisture content.

If a WMA Technology is added at the Plant, the Plant tickets shall include the actual dosage rate.

For drum Plants, the Plant ticket shall be produced at 5 minute intervals and maintained by the vendor for a period of three years after the completion of the project.

For batch Plants, the Plant ticket shall be produced for each batch and maintained by the vendor for a period of three years after the completion of the project. In addition, an asterisk (\*) shall be automatically printed next to any individual batch weight(s) exceeding the following tolerances:

Each Aggregate Component	±1.5% of individual or cumulative target weight for each bin
Mineral Filler	±0.5% of the total batch
Bituminous Material	±0.1% of the total batch
Zero Return (Aggregate)	±0.5% of the total batch
Zero Return (Bituminous Material)	±0.1% of the total batch

The entire batching and mixing interlock cut-off circuits shall interrupt and stop the automatic batching operations when an error exceeding the acceptable tolerance occurs in proportioning.

The scales shall not be manually adjusted during the printing process. In addition, the system shall be interlocked to allow printing only when the scale has come to a complete rest. A unique printed character (m) shall automatically be printed on the ticket when the automatic batching sequence is interrupted or switched to auto-manual or full manual during proportioning.

- d. Aggregates: Aggregate stockpiles shall be managed to prevent segregation and cross contamination. For drum plants only, the percent moisture content at a minimum prior to production and half way through production shall be determined.
- e. Mixture: The dry and wet mix times shall be sufficient to provide a uniform mixture and a minimum particle coating of 95% as determined by AASHTO T 195(M) .

Bituminous concrete mixtures shall contain no more than 0.5% moisture when tested in accordance with AASHTO T 329.

- f. RAP: RAP moisture content shall be determined a minimum of twice daily (prior to production and halfway through production).

- g. Asphalt Binder: A binder log shall be submitted to the Department's Central Lab on a monthly basis.
- h. Warm mix additive: For mechanically foamed WMA, the water injection rate shall be monitored during production and not exceed 2.0% by total weight of binder. For additive added at the Plant, the dosage rate shall be monitored during production.
- i. Plant Laboratory: The Contractor shall maintain a laboratory at the production facility to test bituminous concrete mixtures during production. The laboratory shall have a minimum of 300 square feet, have a potable water source and drainage in accordance with the CT Department of Public Health Drinking Water Division, and be equipped with all necessary testing equipment as well as with a PC, printer, and telephone with a dedicated hard-wired phone line. In addition, the PC shall have internet connection and a functioning web browser with unrestricted access to <https://ctmail.ct.gov>. This equipment shall be maintained in working order at all times and be made available for use by the Engineer.

The laboratory shall be equipped with a heating system capable of maintaining a minimum temperature of 65°F. It shall be clean and free of all materials and equipment not associated with the laboratory. Sufficient light and ventilation must be provided. During summer months, adequate cooling or ventilation must be provided so the indoor air temperature shall not exceed the ambient outdoor temperature.

The laboratory testing apparatus, supplies, and safety equipment shall be capable of performing all tests in their entirety that are referenced in AASHTO R 35 and AASHTO M 323. The Contractor shall ensure that the Laboratory is adequately supplied at all times during the course of the project with all necessary testing supplies and equipment.

The Contractor shall maintain a list of laboratory equipment used in the acceptance testing processes including but not limited to, balances, scales, manometer/vacuum gauge, thermometers, gyratory compactor, clearly showing calibration and/or inspection dates, in accordance with AASHTO R 18. The Contractor shall notify the Engineer if any modifications are made to the equipment within the laboratory. The Contractor shall take immediate action to replace, repair, and/or recalibrate any piece of equipment that is out of calibration, malfunctioning, or not in operation.

#### **M.04.02—Mix Design and Job Mix Formula (JMF)**

##### **1. Curb Mix:**

- a. Requirements: The Contractor shall use bituminous concrete that meets the requirements of Table M.04.02-1. RAP may be used in 5% increments by weight up to 30%.
- b. Basis of Approval: Annually, an approved JMF based on a mix design for curb mix must be on file with the Engineer prior to use. .

Any change in component source of supply or consensus properties must be approved by the Engineer. A revised JMF shall be submitted prior to use.

**TABLE M.04.02 – 1:  
Control Points for Curb Mix Mixtures**

<b>Notes:</b> (a) Compaction Parameter 50gyration $N_{des}$ . (b) The percent passing the #200 sieve shall not exceed the percentage of bituminous asphalt binder.		
<b>Mix</b>	<b>Curb Mix</b>	<b>Production Tolerances from JMF target</b>
<b>Grade of PG Binder content %</b>	<b>PG 64S-22 6.5 - 9.0</b>	<b>0.4</b>
<b>Sieve Size</b>		
# 200	3.0 – 8.0 (b)	2.0
# 50	10 - 30	4
# 30	20 - 40	5
# 8	40 - 70	6
# 4	65 - 87	7
1/4"		
3/8 "	95 - 100	8
1/2 "	100	8
3/4"		8
1"		
2"		
<b>Additionally, the fraction of material retained between any two consecutive sieves shall not be less than 4%</b>		
<b>Mixture Temperature</b>		
<b>Binder</b>	325°F maximum	
<b>Aggregate</b>	280-350° F	
<b>Mixtures</b>	265-325° F	
<b>Mixture Properties</b>		
<b>Air Voids (VA) %</b>	0 – 4.0 (a)	

## 2. Superpave Design Method – S0.25, S0.375, S0.5, and S1

- a. Requirements: All designated mixes shall be designed using the Superpave mix design method in accordance with AASHTO R 35. A JMF based on the mix design shall meet the requirements of Tables M.04.02-2 through Table M.04.02-5. Each JMF must be submitted no less than seven (7) days prior to production and must be approved by the Engineer prior to use. All approved JMFs expire at the end of the calendar year.

All aggregate component consensus properties and tensile strength ratio (TSR) specimens shall be tested at an AASHTO Materials Reference Laboratory (AMRL) by NETTCP certified technicians.

All bituminous concrete mixes shall be tested for stripping susceptibility by performing the tensile strength ratio (TSR) test procedure in accordance with AASHTO T 283(M) at a minimum every 36 months. The compacted specimens may be fabricated at the Plant and then tested at an AMRL accredited facility. TSR specimens, and corresponding JMF shall be submitted with each test report.

i. Superpave Mixtures with RAP: RAP may be used with the following conditions:

- RAP amounts up to 15% may be used with no binder grade modification.
- RAP amounts up to 20% may be used provided a new JMF is approved by the Engineer. The JMF submittal shall include the grade of virgin binder added. The JMF shall be accompanied by a blending chart and supporting test results in accordance with AASHTO M 323 Appendix X1, or by testing that shows the combined binder (recovered binder from the RAP, virgin binder at the mix design proportions, warm mix asphalt additive and any other modifier if used) meets the requirements of the specified binder grade.
- Two representative samples of RAP shall be obtained. Each sample shall be split and one split sample shall be tested for binder content in accordance with AASHTO T 164 and the other in accordance AASHTO T 308.
- RAP material shall not be used with any other recycling option.

ii. Superpave Mixtures with RAS: RAS may be used solely in HMA S1 mixtures with the following conditions:

- RAS amounts up to 3% may be used.
- RAS total binder replacement up to 15% may be used with no binder grade modification.
- RAS total binder replacement up to 20% may be used provided a new JMF is approved by the Engineer. The JMF submittal shall include the grade of virgin binder added. The JMF shall be accompanied by a blending chart and supporting test results in accordance to AASHTO M 323 appendix X1 or by testing that shows the combined binder (recovered binder from the RAP, virgin binder at the mix design proportions, warm mix asphalt additive and any other modifier if used) meets the requirements of the specified binder grade.
- Superpave Mixtures with RAS shall meet AASHTO PP 78 design considerations. The RAS asphalt binder availability factor (F) used in AASHTO PP 78 shall be 0.85.

iii. Superpave Mixtures with CRCG: CRCG may be used solely in HMA S1 mixtures. One percent of hydrated lime, or other accepted non-stripping agent, shall be added to all mixtures containing CRCG. CRCG material shall not be used with any other recycling option.

- b. Basis of Approval: The following information must be included with the JMF submittal:
- Gradation, consensus properties and specific gravities of the aggregate, RAP or RAS.
  - Average asphalt content of the RAP or RAS by AASHTO T 164.
  - Source of RAP or RAS, and percentage to be used.
  - Warm mix Technology, manufacturer's recommended additive rate and tolerances and manufacturer recommended mixing and compaction temperatures.
  - TSR test report and anti-strip manufacturer and recommended dosage rate if applicable.
  - Mixing and compaction temperature ranges for the mix with and without the warm-mix technology incorporated.
  - JMF ignition oven correction factor by AASHTO T 308.

With each JMF submittal, the following samples shall be submitted to the Division of Materials Testing:

- 4 - one quart cans of PG binder, with corresponding Safety Data Sheet (SDS)
- 1 - 50 lbs bag of RAP
- 2 - 50 lbs bag of plant blended virgin aggregate

A JMF may not be approved if any of the properties of the aggregate components or mix do not meet the verification tolerances as described in the Department's current QA Program for Materials, Acceptance and Assurance Testing Policies and Procedures.

Any material based on a JMF, once approved, shall only be acceptable for use when it is produced by the designated plant, it utilizes the same components, and the production of material continues to meet all criteria as specified herein, and component aggregates are maintained within the tolerances shown in Table M.04.02-2. A new JMF must be submitted to the Engineer for approval whenever a new component source is proposed.

Only one mix with one JMF will be approved for production at any one time. Switching between approved JMF mixes with different component percentages or sources of supply is prohibited.

- c. Mix Status: Each facility will have each type of mixture rated based on the results of the previous year's production. Mix Status will be provided to each bituminous concrete producer annually prior to the beginning of the paving season.

The rating criteria are based on compliance with Air Voids and Voids in Mineral Aggregate (VMA) as indicated in Table M.04.03-4 and are calculated as follows:

Criteria A: Percentage of acceptance test results with compliant air voids.

Criteria B: The average of the percentage of acceptance test results with compliant VMA, and percentage of acceptance test results with compliant air voids.

The final rating assigned will be the lower of the rating obtained with Criteria A or B.

Mix status is defined as:

“A” – Approved:

Assigned to each mixture type from a production facility with a current rating of 70% or greater, or to each mixture type completing a successful PPT.

“PPT” – Pre-Production Trial:

Temporarily assigned to each mixture type from a production facility when:

1. there are no compliant acceptance production test results submitted to the Department from the previous year;
2. there is a source change in one or more aggregate components
3. there is a component percentage change of more than 5% by weight;
4. there is a change in RAP percentage;
5. the mixture has a rating of less than 70% from the previous season;
6. a new JMF not previously submitted.

Bituminous concrete mixtures with a “PPT” status cannot be used on Department projects. Testing shall be performed by the Producer with NETTCP certified personnel on material under this status. Test results must confirm that specifications requirements in Table M.04.02-2 and Table M.04.02-5 are met before material can be used. One of the following methods must be used to verify the test results:

Option A: Schedule a day when a Department Inspector can be at the facility to witness testing or,

Option B: When the Contractor or their representative performs testing without being witnessed by an Inspector, the Contractor shall submit the test results and a split sample including 2 gyratory molds, 5,000 grams of boxed bituminous concrete, and 5,000 grams of cooled loose bituminous concrete for verification testing and approval.

Option C: When the Contractor or their representative performs testing without being witnessed by a Department Inspector, the Engineer may verify the mix in the Contractor’s laboratory.

Witnessing or verifying by the Department of compliant test results will change the mix’s status to an “A”.

The differences between the Department’s test results and the Contractor’s must be within the “C” tolerances included in the Department’s QA Program for Materials, Acceptance and Assurance Testing Policies and Procedures in order to be verified.

“U” – Not Approved:

Status assigned to a type of mixture that does not have an approved JMF. . Bituminous concrete mixtures with a “U” status cannot be used on Department projects.

**TABLE M.04.02– 2: Superpave Mixture Design Criteria**

Notes: <sup>(1)</sup> For all mixtures using a WMA technology, the mix temperature shall meet PG binder and WMA manufacturer's recommendations.								
Sieve	S0.25		S0.375		S0.5		S1	
	CONTROL POINTS		CONTROL POINTS		CONTROL POINTS		CONTROL POINTS	
inches	Min (%)	Max (%)	Min (%)	Max (%)	Min (%)	Max (%)	Min (%)	Max (%)
2.0	-	-	-	-	-	-	-	-
1.5	-	-	-	-	-	-	100	-
1.0	-	-	-	-	-	-	90	100
3/4	-	-	-	-	100	-	-	90
1/2	100	-	100	-	90	100	-	-
3/8	97	100	90	100	-	90	-	-
#4	75	90	-	75	-	-	-	-
#8	32	67	32	67	28	58	19	45
#16	-	-	-	-	-	-	-	-
#30	-	-	-	-	-	-	-	-
#50	-	-	-	-	-	-	-	-
#100	-	-	-	-	-	-	-	-
#200	2.0	10.0	2.0	10.0	2.0	10.0	1.0	7.0
VMA (%)	16.5 ± 1		16.0 ± 1		15.0 ± 1		13.0 ± 1	
VA (%)	4.0 ± 1		4.0 ± 1		4.0 ± 1		4.0 ± 1	
Gse	JMF value		JMF value		JMF value		JMF value	
Gmm	JMF ± 0.030		JMF ± 0.030		JMF ± 0.030		JMF ± 0.030	
Dust / binder	0.6 – 1.2		0.6 – 1.2		0.6 – 1.2		0.6 – 1.2	
Mix Temp <sup>(1)</sup>	265 – 325°F		265 – 325°F		265 – 325°F		265 – 325°F	
TSR	≥ 80%		≥ 80%		≥ 80%		≥ 80%	
T-283 Stripping	Minimal, as determined by the Engineer							



**TABLE M.04.02–3: Superpave Consensus Properties Requirements for Combined Aggregate**

Notes: (1) 95/90 denotes that a minimum of 95% of the coarse aggregate, by mass, shall have one fractured face and that a minimum of 90% shall have two fractured faces.. (2) Criteria presented as maximum Percent by mass of flat and elongated particles of materials retained on the #4 sieve, determined at 5:1 ratio.					
Traffic Level	Design ESALs (80 kN), Millions	Coarse Aggregate Angularity <sup>(1)</sup> ASTM D 5821, Minimum %	Fine Aggregate Angularity AASHTO T 304, Method A Minimum %	Flat and Elongated Particles <sup>(2)</sup> ASTM D 4791, Maximum %	Sand Equivalent AASHTO T 176, Minimum %
1	< 0.3	55/- -	40	10	40
2	0.3 to < 3.0	75/- -	40	10	40
3	≥ 3.0	95/90	45	10	45

**TABLE M.04.02– 4: Superpave Traffic Levels and Design Volumetric Properties**

Traffic Level	Design ESALs (million)	Number of Gyration by Superpave Gyrotory Compactor			Percent Density of Gmm from HMA/WMA specimen			Voids Filled with Asphalt (VFA) Based on Nominal mix size – inch			
		Nini	Ndes	Nmax	Nini	Ndes	Nmax	0.25	0.375	0.5	1
1	< 0.3	6	50	75	≤ 91.5	96.0	≤ 98.0	70 - 80	70 - 80	70 - 80	67 - 80
2	0.3 to < 3.0	7	75	115	≤ 90.5	96.0	≤ 98.0	65 - 78	65 - 78	65 - 78	65 - 78
3	≥ 3.0	8	100	160	≤ 90.0	96.0	≤ 98.0	65 – 77	73 - 76	65 - 75	65 - 75

**TABLE M.04.02– 5:  
Superpave Minimum Binder Content by Mix Type and Level**

Mix Type	Level	Binder Content Minimum
S0.25	1	5.70
S0.25	2	5.60
S0.25	3	5.50
S0.375	1	5.70
S0.375	2	5.60
S0.375	3	5.50
S0.5	1	5.10
S0.5	2	5.00
S0.5	3	4.90
S1	1	4.60
S1	2	4.50
S1	3	4.40

**M.04.03— Production Requirements:**

**1. Standard Quality Control Plan (QCP) for Production:**

The QCP for production shall describe the organization and procedures which the Contractor shall use to administer quality control. The QCP shall include the procedures used to control the production process, to determine when immediate changes to the processes are needed, and to implement the required changes. The QCP must detail the inspection, sampling and testing protocols to be used, and the frequency for each.

Control Chart(s) shall be developed and maintained for critical aspect(s) of the production process as determined by the Contractor. The control chart(s) shall identify the material property, applicable upper and lower control limits, and be updated with current test data. As a minimum, the following quality characteristics shall be included in the control charts: percent passing #4 sieve, percent passing #200 sieve, binder content, air voids, Gmm and VMA. The control chart(s) shall be used as part of the quality control system to document variability of the bituminous concrete production process. The control chart(s) shall be submitted to the Engineer the first day of each month.

The QCP shall also include the name and qualifications of a Quality Control Manager. The Quality Control Manager shall be responsible for the administration of the QCP, including compliance with the plan and any plan modifications.

The Contractor shall submit complete production testing records to the Engineer within 24 hours in a manner acceptable to the Engineer.

The QCP shall also include the name and qualifications of any outside testing laboratory performing any QC functions on behalf of the Contractor. The QCP must also include a list of sampling & testing methods and frequencies used during production, and the names of all Quality Control personnel and their duties.

Approval of the QCP does not imply any warranty by the Engineer that adherence to the plan will result in production of bituminous concrete that complies with these specifications. The Contractor shall submit any changes to the QCP as work progresses.

## **2. Acceptance Requirements:**

### **i. General:**

Acceptance samples shall be obtained from the hauling vehicles and tested by the Contractor at the Plant.

The Contractor shall submit all acceptance tests results to the Engineer within 24 hours or prior to the next day's production. All acceptance test specimens and supporting documentation must be retained by the Contractor and may be disposed of with the approval of the Engineer. All quality control specimens shall be clearly labeled and separated from the acceptance specimens.

Contractor personnel performing acceptance sampling and testing must be present at the facility prior to, during, and until completion of production, and be certified as a NETTCP HMA Plant Technician or Interim HMA Plant Technician and be in good standing. Production of material for use on State projects must be suspended by the Contractor if such personnel are not present. Technicians found by the Engineer to be non-compliant with NETTCP policies and procedures or Department policies may be removed by the Engineer from participating in the acceptance testing process for Department projects until their actions can be reviewed.

Anytime during production that testing equipment becomes defective or inoperable, production can continue for a maximum of 1 hour. The Contractor shall obtain box sample(s) in accordance with Table M.04.03-2 to satisfy the daily acceptance testing requirement for the quantity shipped to the project. The box sample(s) shall be tested once the equipment issue has been resolved to the satisfaction of the Engineer. Production beyond 1 hour may be considered by the Engineer. Production will not be permitted beyond that day until the subject equipment issue has been resolved.

Verification testing will be performed by the Engineer in accordance with the Department's QA Program for Materials.

Should the Department be unable to verify the Contractor's acceptance test result(s) due to a failure of the Contractor to retain acceptance test specimens or supporting documentation, the Contractor shall review its quality control plan, determine the cause of the nonconformance and

respond in writing within 24 hours to the Engineer describing the corrective action taken. In addition, the Contractor must provide supporting documentation or test results to validate the subject acceptance test result(s). The Engineer may invalidate any adjustments for material corresponding to the subject acceptance test(s). Failure of the Contractor to adequately address quality control issues at a facility may result in suspension of production for Department projects at that facility.

**ii. Curb Mix Acceptance Sampling and Testing Procedures:**

Curb Mix shall be tested in accordance to Table M.04.03-1 by the Contractor at a frequency of one test per every 250 tons of cumulative production, regardless of the day of production.

**TABLE M.04.03 – 1: Curb Mix Acceptance Test Procedures**

Protocol	Reference	Description
1	AASHTO T 30(M)	Mechanical Analysis of Extracted Aggregate
2	AASHTO T 168	Sampling of Bituminous Concrete
3	AASHTO T 308	Binder content by Ignition Oven method (adjusted for aggregate correction factor)
4	AASHTO T 209(M) <sup>(2)</sup>	Theoretical Maximum Specific Gravity and Density of Bituminous Paving Mixtures
5	AASHTO T 312 <sup>(2)</sup>	<sup>(1)</sup> Superpave Gyrotory molds compacted to N <sub>des</sub>
6	AASHTO T 329	Moisture Content of Hot-Mix Asphalt (HMA) by Oven Method

**Notes:** <sup>(1)</sup> One set equals two six-inch molds. Molds to be compacted to 50 gyrations

<sup>(2)</sup> Once per year or when requested by the Engineer

a. Determination of Off-Test Status:

- i. Curb Mix is considered “off test” when the test results indicate that any single value for bitumen content or gradation are not within the tolerances shown in Table M.04.02-1. If the mix is “off test”, the Contractor must take immediate actions to correct the deficiency and a new acceptance sample shall be tested on the same day or the following day of production.
- ii. When multiple silos are located at one site, mixture supplied to one project is considered as coming from one source for the purpose of applying the “off test” status.
- iii. The Engineer may cease supply from the plant when test results from three consecutive samples are not within the JMF tolerances or the test results from two consecutive samples not within the control points indicated in Table M.04.02-1 regardless of production date.

b. JMF revisions

- i. If a test indicates that the bitumen content or gradation are outside the tolerances, the Contractor may make a single JMF revision as allowed by the Engineer prior to any additional testing. Consecutive test results outside the requirements of Table M.04.02-1 JMF tolerances may result in rejection of the mixture.
- ii. Any modification to the JMF shall not exceed 50% of the JMF tolerances indicated in Table M.04.02-1 for any given component of the mixture without approval of the Engineer. When such an adjustment is made to the bitumen, the corresponding production percentage of bitumen shall be revised accordingly.

### iii. Superpave Mix Acceptance:

#### a. Sampling and Testing Procedures

Production Lot: The Lot will be defined as one of the following types:

- Non-PWL Production Lot for total estimated project quantities per mixture less than 3500 tons: All mixture placed during a single continuous paving operation.
- PWL Production Lot for total estimated project quantities per mixture of 3500 tons or more: Each 3500 tons of mixture produced within 30 calendar days.

Production Sub Lot:

- For Non-PWL: As defined in Table M.04.03 – 2
- For PWL: 500 tons (the last Sub Lot may be less than 500 tons)

Partial Production Lots (For PWL only): A Lot with less than 3500 tons due to:

- completion of the Course
- a Job Mix Formula revision due to changes in:
  - o cold feed percentages over 5%
  - o target combined gradation over 5%
  - o target binder over 0.15%
  - o any component specific gravity
- a Lot spanning 30 calendar days

The acceptance sample(s) location(s) shall be selected using stratified – random sampling in accordance with ASTM D 3665 based on:

- the total daily estimated tons of production for non-PWL lots, or
- the total lot size for PWL lots.

One acceptance sample shall be obtained and tested per Sub Lot. The Engineer may direct that additional acceptance samples be obtained. For non-PWL lots, one acceptance test shall always be performed in the last sub-lot based on actual tons of material produced.

For Non-PWL lots, quantities of the same mixture per plant may be combined daily for multiple State projects to determine the number of sub lots.

The payment adjustment will be calculated as described in 4.06.

**TABLE M.04.03 – 2:  
Superpave Acceptance Testing Frequency per Type/Level/Plant for Non-PWL lots**

Daily quantity produced in tons (lot)	Number of Sub Lots/Tests
0 to 150	0, Unless requested by the Engineer
151 to 500	1
501 to 1,000	2
1,001 to 2,000	3
2,001 or greater	1 per 500 tons or portions thereof

The following test procedures shall be used for acceptance:

**TABLE M.04.03– 3: Superpave Acceptance Testing Procedures**

Protocol	Procedure	Description
1	AASHTO T 168	Sampling of bituminous concrete
2	AASHTO R 47	Reducing samples to testing size
3	AASHTO T 308	Binder content by ignition oven method (adjusted for aggregate correction factor)
4	AASHTO T 30(M)	Gradation of extracted aggregate for bituminous concrete mixture
5	AASHTO T 312	<sup>(1)</sup> Superpave gyratory molds compacted to $N_{des}$
6	AASHTO T 166	<sup>(2)</sup> Bulk specific gravity of bituminous concrete
7	AASHTO R 35	<sup>(2)</sup> Air voids, VMA
8	AASHTO T 209(M)	Maximum specific gravity of bituminous concrete (average of two tests)
9	AASHTO T 329	Moisture content of bituminous concrete

**Notes:** <sup>(1)</sup> One set equals two six-inch molds. Molds to be compacted to  $N_{max}$  for PPTs and to  $N_{des}$  for production testing. The first subplot of the year will be compacted to  $N_{max}$

<sup>(2)</sup> Average value of one set of six-inch molds.

If the average ignition oven corrected binder content differs by 0.3% or more from the average of the Plant ticket binder content in five (5) consecutive tests regardless of the production date (moving average), the Contractor shall immediately investigate, determine an assignable cause and correct the issue. When two consecutive moving average differences are 0.3% or more and no assignable cause has been established, the Engineer may require a new ignition oven aggregate correction factor to be performed or to adjust the current factor by the average of the differences between the corrected binder content and production Plant ticket for the last five (5) acceptance results.

The test specimen must be placed in an ignition oven for testing in accordance with AASHTO T 308 within thirty minutes of being obtained from the hauling vehicle and the test shall start immediately after.

The Contractor shall perform TSR testing within 30 days after the start of production for all design levels of HMA- and PMA- S0.5 plant-produced mixtures, in accordance with AASHTO T 283(M). The TSR test shall be performed at an AMRL certified laboratory by NETTCP certified technicians. The compacted specimens may be fabricated at the Plant and then tested at an AMRL accredited facility. The test results and specimens shall be submitted to the Engineer for review. Superpave mixtures that require anti-strip additives (either liquid or mineral) shall continue to meet all requirements specified herein for binder and bituminous concrete. The Contractor shall submit the name, manufacturer, percent used, technical datasheet and SDS for the anti-strip additive (if applicable) to the Engineer.

b. Determination of Off-Test Status:

- i. Superpave mixes shall be considered "*off test*" when any Control Point Sieve, binder content, VA, VMA, or Gmm value is outside of the limits specified in Table M.04.03-4 or the target binder content at the Plant is below the minimum binder content stated in Table M.04.02-5. Note that further testing of samples or portions of samples not initially tested for this purpose cannot be used to change the status.
- ii. Any time the bituminous concrete mixture is considered Off-test:
  1. The Contractor shall notify the Engineer when the Plant is "*off test*" for any mix design that is delivered to the project in any production day. When multiple silos are located at one site, mixture supplied to one project is considered as coming from one source for the purpose of applying the "*off test*" determination.
  2. The Contractor must take immediate actions to correct the deficiency, minimize "*off test*" production to the project, and obtain an additional Process Control (PC) test after any corrective action to verify production is in conformance to the specifications. A PC test will not be used for acceptance and is solely for the use of the Contractor in its quality control process.

c. Cessation of Supply for Superpave Mixtures in non-PWL lots:

A mixture shall not be used on Department's projects when it is "off test" for:

- i. four (4) consecutive tests in any combination of VA, VMA or Gmm, regardless of date of production, or,
- ii. two (2) consecutive tests in the Control Point sieves in one production shift.

As a result of cessation of supply, the mix status will be changed to PPT.

d. JMF revisions:

JMF revisions are only permitted prior to or after a production shift. A JMF revision is effective from the time it was submitted and is not retroactive to the previous test(s).

JMF revisions shall be justified by a documented trend of test results.

Revisions to aggregate and RAP specific gravities are only permitted when testing is performed at an AMRL certified laboratory by NETTCP certified technicians.

A JMF revision is required when the Plant target RAP and/or bin percentage deviates by more than 5% and/or the Plant target binder content deviates by more than 0.15% from the active JMF.



**TABLE M.04.03– 4: Superpave Mixture Production Requirements**

<b>Notes:</b> (1) 300°F minimum after October 15. (2) JMF tolerances shall be defined as the limits for production compliance. (3) For all mixtures with WMA technology, changes to the minimum aggregate temperature will require Engineer's approval. (4) For PMA and mixtures with WMA technology, the mix temperature shall meet manufacturer's recommendations. In addition, for all mixtures with WMA technology, the maximum mix temperature shall not exceed 325°F.(5) 0.4 for PWL lots (6) 1.3 for PWL lots (7) 1.2 for PWL lots									
	<b>S0.25</b>		<b>S0.375</b>		<b>S0.5</b>		<b>S1</b>		<b>Tolerances</b>
Sieve	CONTROL POINTS		CONTROL POINTS		CONTROL POINTS		CONTROL POINTS		<b>From JMF Targets <sup>(2)</sup></b>
inches	Min(%)	Max(%)	Min(%)	Max(%)	Min(%)	Max(%)	Min(%)	Max(%)	±Tol
1.5	-	-	-	-	-	-	100	-	
1.0	-	-	-	-	-	-	90	100	
3/4	-	-	-	-	100	-	-	90	
1/2	100	-	100	-	90	100	-	-	
3/8	97	100	90	100	-	90	-	-	
#4	75	90	-	75	-	-	-	-	
#8	32	67	32	67	28	58	19	45	
#16	-	-	-	-	-	-	-	-	
#200	2.0	10.0	2.0	10.0	2.0	10.0	1.0	7.0	
Pb	JMF value		JMF value		JMF value		JMF value		0.3 <sup>(5)</sup>
VMA (%)	16.5		16.0		15.0		13.0		1.0 <sup>(6)</sup>
VA (%)	4.0		4.0		4.0		4.0		1.0 <sup>(7)</sup>
Gmm	JMF value		JMF value		JMF value		JMF value		0.030
Agg. Temp <sup>(3)</sup>	280 – 350F		280 – 350F		280 – 350F		280 – 350F		
Mix Temp <sup>(4)</sup>	265 – 325 F <sup>(1)</sup>		265 – 325 F <sup>(1)</sup>		265 – 325 F <sup>(1)</sup>		265 – 325 F <sup>(1)</sup>		
Prod. TSR	N/A		N/A		≥80%		N/A		
T-283 Stripping	N/A		N/A		Minimal as determined by the Engineer		N/A		

**TABLE M.04.03– 5:  
Superpave Traffic Levels and Design Volumetric Properties**

Traffic Level	Design ESALs	Number of Gyration by Superpave Gyrotory Compactor	
	(million)	Nini	Ndes
1	< 0.3	6	50
2	0.3 to < 3.0	7	75
3	≥3.0	8	100

**TABLE M.04.03-6:  
Modifications to Standard AASHTO and ASTM Test Specifications and Procedures**

AASHTO Standard Method of Test	
Reference	Modification
<b>T 30</b>	Section 7.2 thru 7.4 Samples are not routinely washed for production testing
<b>T 168</b>	<p>Samples are taken at one point in the pile. Samples from a hauling vehicle are taken from only one point instead of three as specified.</p> <p>Selection of Samples: Sampling is equally important as the testing, and the sampler shall use every precaution to obtain samples that are truly representative of the bituminous mixture.</p> <p>Box Samples: In order to enhance the rate of processing samples taken in the field by construction or maintenance personnel the samples will be tested in the order received and data processed to be determine conformance to material specifications and to prioritize inspections by laboratory personnel.</p>
<b>T 195</b>	Section 4.3 only one truck load of mixture is sampled. Samples are taken from opposite sides of the load.
<b>T 209</b>	<p>Section 7.2 The average of two bowls is used proportionally in order to satisfy minimum mass requirements.</p> <p>8.3 Omit Pycnometer method.</p>
<b>T 283</b>	When foaming technology is used, the material used for the fabrication of the specimens shall be cooled to room temperature, and then reheated to the manufactures recommended compaction temperature prior to fabrication of the specimens.

<b>AASHTO Standard Recommended Practices</b>	
<b>Reference</b>	<b>Modification</b>
<b>R 26</b>	<p>All laboratory technician(s) responsible for testing PG-binders be certified or Interim Qualified by the New England Transportation Technician Certification Program (NETTCP) as a PG Asphalt Binder Lab Technician.</p> <p>All laboratories testing binders for the Department are required to be accredited by the AASHTO Materials Reference Laboratory (AMRL).</p> <p>Sources interested in being approved to supply PG-binders to the Department by use of an “in-line blending system,” must record properties of blended material, and additives used.</p> <p>Each source of supply of PG-binder must indicate that the binders contain no additives used to modify or enhance their performance properties. Binders that are manufactured using additives, modifiers, extenders etc., shall disclose the type of additive, percentage and any handling specifications/limitations required.</p> <p>All AASHTO M 320 references shall be replaced with AASHTO M 332.</p> <p>Once a month, one split sample and test results for each asphalt binder grade and each lot shall be submitted by the PG binder supplier to the Department’s Central Lab. Material remaining in a certified lot shall be re-certified no later than 30 days after initial certification. Each April and September, the PG binder supplier shall submit test results for two (2) BBR tests at two (2) different temperatures in accordance with AASHTO R 29.</p>

## **ITEM 0020903A – LEAD COMPLIANCE FOR MISCELLANEOUS EXTERIOR TASKS**

### **Description:**

Work under this item shall include the special handling measures and work practices required for miscellaneous exterior tasks that impact materials containing or covered by lead paint. Lead paint includes paint found to contain **any** detectable amount of lead by Atomic Absorption Spectrophotometry (AAS) or X-Ray Fluorescence (XRF). Examples of typical miscellaneous exterior tasks includes; work impacting signs, guiderails, minor bridge rehabilitation, catenary structures, canopy structures, spot/localized paint removal, etc.

All activities shall be performed in accordance with the OSHA Lead in Construction Regulations (29 CFR 1926.62), the USEPA RCRA Hazardous Waste Regulations (40 CFR Parts 260 through 274), and the CTDEEP Hazardous Waste Regulations (RCSA 22a-209-1 and 22a-449(c)).

All activities shall be performed by individuals with appropriate levels of OSHA lead awareness and hazard communication training and shall supervised by the Contractors Competent Person on the job site at all times. The Contractors Competent Person is one who is capable of identifying existing and predictable hazards in the surroundings or working conditions which are unsanitary, hazardous or dangerous to employees, and who has authorization to take prompt corrective measures to eliminate them.

Deviations from these Specifications require the written approval of the Engineer.

### **Materials:**

All materials shall be delivered to the job site in the original packages, containers, or bundles bearing the name of the manufacturer, the brand name and product technical description, with MSDS sheets as applicable.

No damaged or deteriorating materials shall be used. If material becomes contaminated with lead, the material shall be decontaminated or disposed of as lead-containing waste material. The cost to decontaminate and dispose of this material shall be at the expense of the Contractor.

The following material requirements are to be met if to be used during the work:

Fire retardant polyethylene sheet shall be in roll size to minimize the frequency of joints, with factory label indicating minimum six (6) mil thickness.

Polyethylene disposable bags shall be minimum six (6) mils thick.

Tape (or equivalent) product capable of sealing joints in adjacent polyethylene sheets and for the attachment of polyethylene sheets to finished or unfinished surfaces must be capable of adhering under both dry and wet conditions.

Cleaning Agents and detergent shall be lead specific, such as TriSodium Phosphate (TSP).

Chemical strippers and chemical neutralizers shall be compatible with the substrate as well as with each other. Such chemical stripper shall contain less than 50% Volatile Organic Compounds (VOCs) by weight in accordance with RCSA 22a-174-40 Table 40-1.

Labels and warning signs shall conform to 29 CFR 1926.62, 40 CFR 260 through 274 and 49 CFR 172 as appropriate.

Air filtration devices and vacuum units shall be equipped with High-Efficiency Particulate Air (HEPA) filters.

### **Construction Methods:**

#### **(1) Pre-Abatement Submittals and Notices**

A. Prior to the start of any work on a contiguous per site basis that will generate hazardous lead waste above conditionally exempt small quantities (greater than 100 kg/month or greater than 1000 kg at any time), the Contractor shall obtain from the Engineer on a contiguous per site basis a temporary EPA Hazardous Waste Generators ID number, unless otherwise directed by the Engineer. Temporary EPA ID numbers are good for six months from the date they are issued and can be extended once, for a maximum of six months and can't be used for longer than one year. The Contractor will be responsible for notifying the Engineer when an extension is needed.

B. Fifteen (15) working days prior to beginning work that impacts lead paint, the Contractor shall submit the following to the Engineer:

1. Work plan for work impacting lead paint including engineering controls, methods of containment of debris and work practices to be employed, as needed, to minimize employee exposure and prevent the spread of lead contamination outside the Regulated Area.
2. Copies of all employee certificates, dated within the previous twelve (12) months, relating to OSHA lead awareness and hazard communication training and training in the use of lead-safe work practices. SSPC training programs may be accepted as meeting these requirements if it can be demonstrated that such training addressed all required topics.

This information shall be updated and resubmitted annually, or as information changes, for the duration of the activities impacting lead to verify continued compliance.

3. Name and qualifications of Contractor's OSHA Competent Person under 29 CFR 1926.62.

4. Documentation from the Contractor, typed on company letterhead and signed by the Contractor, certifying that all employees listed therein have received the following:
  - a. medical monitoring within the previous twelve (12) months, as required in 29 CFR 1926.62;
  - b. biological monitoring within the previous six (6) months, as required in 29 CFR 1926.62;
  - c. respirator fit testing within the previous twelve (12) months, as required in 29 CFR 1910.134 (for those who don a tight-fitting face piece respirator)

This information shall be updated and resubmitted annually, or as information changes, for the duration of the activities impacting lead to verify continued compliance.

5. Names of the proposed non-hazardous construction and demolition (C&D) lead debris bulky waste disposal facility (CTDEEP-permitted Solid Waste landfill).
6. Names of the proposed scrap metal recycling facilities. The Contractor shall submit to the Engineer all documentation necessary to demonstrate the selected facility is able to accept lead-painted scrap metal.
7. Names of the proposed hazardous waste disposal facility (selected from the Department approved list provided herein), and copies of each facilities acceptance criteria and sampling frequency requirements.
8. Copies of the proposed hazardous waste transporters current USDOT Certificate of Registration for Hazardous Materials Transport, and the proposed transporters current Hazardous Waste Transporter Permits for the State of Connecticut and the waste destination State.
9. Negative exposure assessments conducted within the previous 12 months documenting that employee exposure to lead for each task is below the OSHA Action Level of  $30 \mu\text{g}/\text{m}^3$ . If a negative exposure assessment has not been conducted, the Contractor shall submit its air monitoring program for the work tasks as part of the Work Plan. Until a negative exposure assessment is developed for each task impacting lead paint, the Contractor shall ensure that all workers and authorized persons entering the Regulated Area wear protective clothing and respirators in accordance with OSHA 29 CFR 1926.62.

No activity shall commence until all required submittals have been received and found acceptable to the Engineer. Those employees added to the Contractor's original list will be allowed to perform work only upon submittal of acceptable documentation to, and review by, the Engineer.

Contractor shall provide the Engineer with a minimum of 48 hours notice in advance of scheduling, changing or canceling work activities.

## **(2) Lead Abatement Provisions**

### **A. General Requirements:**

All employees of the Contractor who perform work impacting lead paint shall be properly trained to perform such duties. In addition, the Contractor shall instruct all workers in all aspects of personnel protection, work procedures, emergency evacuation procedures and use of equipment including procedures unique to this project.

Contractor shall provide all labor, materials, tools, equipment, services, testing, and incidentals which are necessary or required to perform the work in accordance with applicable governmental regulations, industry standards and codes, and these Specifications.

Prior to beginning work, the Engineer and Contractor shall perform a visual survey of each work area and review conditions.

As necessary, the Contractor shall:

Shut down and lock out electrical power, including all receptacles and light fixtures, where feasible. The use or isolation of electrical power will be coordinated with all other ongoing uses of electrical power at the site.

If adequate electrical supply is not available at the site, the Contractor shall supply temporary power. Such temporary power shall be sufficient to provide adequate lighting and power the Contractor's equipment. The Contractor is responsible for proper connection and installation of electrical wiring and shall ensure safe installation of electrical equipment in compliance with applicable electrical codes and OSHA requirements.

If water is not available at the site for the Contractor's use, the Contractor shall supply sufficient water for each shift to operate the wash facility/decontamination shower units in addition to the water needed at the work area.

The Engineer may provide a Project Monitor to monitor compliance of the Contractor and protect the interests of the Department. In such cases, no activity impacting lead paint shall be performed until the Project Monitor is on-site. Where no Project Monitor will be provided, Contractor shall proceed at the direction of the Engineer. Environmental sampling, including ambient air sampling, TCLP waste stream sampling, and dust wipe sampling, will be conducted by the State as it deems necessary throughout the project. Air monitoring to comply with the Contractor's obligations under OSHA remains solely responsibility of the Contractor.

If at any time, procedures for engineering, work practice, administrative controls or other topics are anticipated to deviate from those documented in the submitted and accepted Lead Work Plan,

the Contractor shall submit a modification of its existing plan for review and acceptance by the Engineer prior to implementing the change.

If air samples collected outside of the Regulated Area during activities impacting lead paint indicate airborne lead concentrations greater than original background levels or 30 ug/m<sup>3</sup>, whichever is larger, or if at any time visible emissions of lead paint extend out from the Regulated Area, an examination of the Regulated Area shall be conducted and the cause of such emissions corrected. Cleanup of surfaces outside the Regulated Area using HEPA vacuum equipment or wet cleaning techniques shall be done prior to resuming work.

Work outside the initial designated area(s) will not be paid for by the Engineer. The Contractor will be responsible for all costs incurred from these activities including repair of any damage.

#### B. Regulated Area

The Contractor shall establish a Regulated Area through the use of appropriate barrier tape or other means to control unauthorized access into the area where activities impacting lead paint are occurring. Warning signs meeting the requirements of 29 CFR 1926.62 shall be posted at all approaches to Regulated Areas. These signs shall read:

DANGER  
LEAD WORK AREA  
MAY DAMAGE FERTILITY OR THE UNBORN CHILD  
CAUSES DAMAGE TO THE CENTRAL NERVOUS SYSTEM  
DO NOT EAT, DRINK, OR SMOKE IN THIS AREA

The Contractor shall implement appropriate engineering controls such as poly drop cloths, local exhaust ventilation, wet dust suppression methods, etc. as necessary, and as approved by the Engineer, to prevent the spread of lead contamination beyond the Regulated Area in accordance with the Contractor's approved work plan. Should the previously submitted work plan prove to be insufficient to contain the contamination, the Contractor shall modify its plan and submit it for review by the Engineer.

#### C. Wash Facilities:

The Contractor shall provide handwash facilities in compliance with 29 CFR 1926.51(f) and 29 CFR 1926.62 regardless of airborne lead exposure.

If employee exposure to airborne lead exceeds the OSHA Permissible Exposure Limit of 50 micrograms per cubic meter (ug/m<sup>3</sup>), shower rooms must be provided. The Shower Room shall be of sufficient capacity to accommodate the number of workers. One shower stall shall be provided for each eight (8) workers. Showers shall be equipped with hot and cold or warm running water. Shower water shall be collected and filtered using best available technology and disposed of in accordance with all Federal, State and local laws, regulations and ordinances.



#### D. Personal Protection:

The Contractor shall initially determine if any employee performing construction tasks impacting lead paint may be exposed to lead at or above the OSHA Action Level of 30  $\mu\text{g}/\text{m}^3$ . Assessments shall be based on initial air monitoring results as well as other relevant information. The Contractor may rely on historical air monitoring data obtained within the past 12 months under workplace conditions closely resembling the process, type of material, control methods, work practices and environmental conditions used and prevailing in the Contractors current operations to satisfy the exposure assessment requirements. Monitoring shall continue as specified in the OSHA standard until a negative exposure assessment is developed.

Until a negative exposure assessment is developed for each task impacting lead paint, the Contractor shall ensure that all workers and authorized person entering the Regulated Area wear protective clothing and respirators in accordance with OSHA 29 CFR 1926.62. Protective clothing shall include impervious coveralls with elastic wrists and ankles, head covering, gloves and foot coverings. Sufficient quantities shall be provided to last throughout the duration of the project.

Protective clothing provided by the Contractor and used during chemical removal operations shall be impervious to caustic materials. Gloves provided by the Contractor and used during chemical removal shall be of neoprene composition with glove extenders.

Respiratory protective equipment shall be provided and selection shall conform to 42 CFR Part 84, 29 CFR Part 1910.134, and 29 CFR Part 1926.62. A formal respiratory protection program must be implemented in accordance with 29 CFR Part 1926.62 and Part 1910.134.

#### E. Air Monitoring Requirements

The Contractor shall:

1. Provide air monitoring equipment including sample filter cassettes of the type and quantity required to properly monitor operations and personnel exposure surveillance throughout the duration of the project.
2. Conduct initial exposure monitoring to determine if any employee performing construction tasks impacting lead paint may be exposed to lead at or above the OSHA Action Level of 30 micrograms per cubic meter. Monitoring shall continue as specified in the OSHA standard until a negative exposure assessment is developed.
3. Conduct personnel exposure assessment air sampling, as necessary, to assure that workers are using appropriate respiratory protection in accordance with OSHA Standard 1926.62. Documentation of air sampling results must be recorded at the work site within twenty-four (24) hours and shall be available for review until the job is complete.

## F. Lead Abatement Procedures

The Contractor's Competent Person shall be at the job site at all times during work impacting lead.

Work impacting lead paint shall not begin until authorized by the Engineer, following a pre-work visual inspection by the Project Monitor or Engineer to verify existing conditions.

Any activity impacting lead painted surfaces shall be performed in a manner which minimizes the spread of lead dust contamination and generation of airborne lead.

**The Contractor shall conduct exposure assessments for all tasks which impact lead paint in accordance with 29 CFR 1926.62(d) and shall implement appropriate personal protective equipment until negative exposure assessments are developed.**

**All work impacting the materials identified below shall be conducted within an established Regulated Area with a remote wash facility/decontamination system in accordance with "C. Wash Facilities" and the OSHA Lead in Construction Standard. In accordance with 29 CFR 1926.62, engineering controls and work practices shall be utilized to prevent the spread of lead dust and debris beyond the Regulated Area and limit the generation of airborne lead. All wastes containing lead paint shall be properly contained and secured for storage, transportation and disposal.**

The Contractor shall ensure proper entry and exit procedures for workers and authorized persons who enter and leave the Regulated Area. All workers and authorized persons shall leave the Regulated Area and proceed directly to the wash or shower facilities where they will HEPA vacuum gross debris from work suit, remove and dispose of work suit, wash and dry face and hands, and vacuum clothes. Lead chips and dust must not be removed by blowing or shaking of clothing. Wash water shall be collected, filtered, and disposed of in accordance with Federal, State and local water discharge standards. Any permit required for such discharge shall be the responsibility of the Contractor.

No one shall eat, drink, smoke, chew gum or tobacco, or apply cosmetics while in the Regulated Area.

Data from the limited lead testing performed by the Engineer is documented in the reports listed in the "Notice to Contractor – Hazardous Materials Investigations" or is presented herein. Under no circumstances shall this information be the sole means used by the Contractor for determining the extent of lead painted materials. The Contractor shall be responsible for verification of all field conditions affecting performance of the work as described in these Specifications in accordance with OSHA, USEPA, USDOT and CTDEEP standards. Compliance with the applicable requirements is solely the responsibility of the Contractor.

The following details the extent of each phase of operation designated for this project. Phase areas may be combined or divided at the direction of the Engineer. Proceed through the sequencing of the work phases under the direction of the Engineer.

- **Detectable amounts of lead were identified on the painted metal surfaces of the traffic signal controller at Intersection No. 087-XXX (Rubber Avenue at Hoadley and Melbourne Street.**

<b>Traffic Signal Controller</b>	<b>Metal</b>	<b>Grey</b>	<b>-0.2-0.1 mg/cm<sup>2</sup> 0.19% by weight</b>
<b>Traffic Signal Pole &amp; Base</b>	<b>Metal</b>	<b>Grey</b>	<b>-0.3-0.2 mg/cm<sup>2</sup></b>

- **Any paint waste debris generated from the painted metal surfaces of the traffic signal span pole, base, and controller is presently presumed as non-RCRA, non-hazardous waste.**
- **OSHA Worker protection still applies.**

**While conducting work to the traffic signal span poles/bases, where it is necessary to impact the lead painted surfaces, the Contractor shall either:**

- a. **Remove the paint to be impacted prior to impacting the substrate in accordance with OSHA Lead in Construction Standard 29CFR 1926.62, or**
- b. **Impact the substrate using mechanical means with the paint in place in accordance with OSHA Lead in Construction Standard 29CFR 1926.62.**

**The Contractor shall submit a Work Plan to ConnDOT outlining the exact procedures that will be used to perform the work, contain the spread of lead debris and protect the employees performing the required renovation work impacting the lead paint. No work shall be started by the Contractor until the Work Plan is approved by the Engineer.**

**All work impacting the lead paint materials shall be conducted within an established Regulated Area with a remote wash facility/decontamination system in accordance with “C. Wash Facilities” and the OSHA Lead in Construction Standard. In accordance with 29 CFR 1926.62, engineering controls and work practices shall be utilized to prevent the spread of lead dust and debris beyond the Regulated Area and limit the generation of airborne lead. All wastes containing lead paint shall be properly contained and secured for storage, transportation and disposal.**

**Within the project limits, any paint waste to be generated is presently presumed to be hazardous waste. Should the paint be removed from the components, the Engineer will conduct TCLP testing or mass balance calculations on a representative sample of the lead paint waste materials to confirm if it is classified as a hazardous waste or non-hazardous, non-RCRA waste. Should the waste material be determined to be hazardous, it shall be**

**handled and disposed of in accordance with USEPA/CTDEEP Hazardous Waste Regulations as described under this Item 0020903A. If the waste material is determined to be non-hazardous, it shall be disposed of as non-hazardous, non-RCRA waste as described under this Item 0020903A.**

**All steel and metal components generated from the miscellaneous exterior work tasks (painted or not) shall be segregated and recycled as scrap metal. The recycling of scrap metal (regardless of lead paint concentration) is exempt from USEPA RCRA and CTDEEP Hazardous Waste Regulation.**

Should lead contamination be discovered outside of the Regulated Area, the Contractor shall immediately stop all work in the Regulated Area, eliminate causes of such contamination and take steps to decontaminate non-work areas.

Special Requirements:

1. Demolition/Renovation:
  - a. Demolish/renovate in a manner which minimizes the spread of lead contamination and generation of lead dust.
  - b. Implement dust suppression controls, such as misters, local exhaust ventilation, etc. to minimize the generation of airborne lead dust.
  - c. Segregate work areas from non-work areas through the use of barrier tape, drop cloths, etc.
  - d. Clean up immediately after renovation/demolition has been completed
2. Chemical Removal:
  - a. Apply chemical stripper in quantities and for durations specified by manufacturer.
  - b. Where necessary, scrape lead paint from surface down to required level of removal (i.e. stabilized surface, bare substrate with no trace of residual pigment, etc.). Use sanding, hand scraping, and dental picks to supplement chemical methods as necessary.
  - c. Apply neutralizer compatible with substrate and chemical agent to substrate following removal in accordance with manufacturer's instructions.
  - d. Protect adjacent surfaces from damage from chemical removal.
  - e. Maintain a portable eyewash station in the work area.
  - f. Wear respirators that will protect workers from chemical vapors.

- g. Do not apply caustic agents to aluminum surfaces.

3. Mechanical Paint Removal:

- a. Provide sanders, grinders, rotary wire brushes, or needle gun removers equipped with a HEPA filtered vacuum dust collection system. Cowling on the dust collection system for orbital-type tools must be capable of maintaining a continuous tight seal with the surface being abated. Cowling on the dust collection system for reciprocating-type tools shall promote an effective vacuum flow of loosened dust and debris. Inflexible cowlings may be used on flat surfaces only. Flexible contoured cowlings are required for curved or irregular surfaces.
- b. Provide HEPA vacuums that are high performance designed to provide maximum static lift and maximum vacuum system flow at the actual operating vacuum condition with the shroud in use. The HEPA vacuum shall be equipped with a pivoting vacuum head.
- c. Remove lead paint from surface down to required level of removal (i.e. stabilized surface, bare substrate with no trace of residual pigment, etc.). Use chemical methods, hand scraping, and dental picks to supplement abrasive removal methods as necessary.
- d. Protect adjacent surfaces from damage from abrasive removal techniques.
- e. "Sandblasting" type removal techniques shall not be allowed.

4. Component Removal/Replacement:

- a. Wet down components which are to be removed to reduce the amount of dust generated during the removal process.
- b. Remove components utilizing hand tools, and follow appropriate safety procedures during removal. Remove the components by approved methods which will provide the least disturbance to the substrate material. Do not damage adjacent surfaces.
- c. Clean up immediately after component removals have been completed. Remove any dust located behind the component removed.

G. Prohibited Removal Methods:

The use of heat guns in excess of 700 degrees Fahrenheit to remove lead paint is prohibited.

The use of sand, steel grit, air, CO<sub>2</sub>, baking soda, or any other blasting media to remove lead or lead paint without the use of a HEPA ventilated contained negative pressure enclosure is prohibited.

Power/pressure washing shall not be used to remove lead paint.

Compressed air shall not be utilized to remove lead paint.

Chemical strippers containing Methylene Chloride are prohibited. Any chemical stripping may be prohibited on a project by project basis.

Power tool assisted grinding, sanding, cutting, or wire brushing of lead paint without the use of cowed HEPA vacuum dust collection systems is prohibited.

Lead paint burning, busting of rivets painted with lead paint, welding of materials painted with lead paint, and torch cutting of materials painted with lead paint is prohibited. Where cutting, welding, busting, or torch cutting of materials is required, lead paint in the affected area must be removed first.

Chemical stripping of coatings from bridge components is generally prohibited unless specifically allowed on a project by project basis.

#### H. Clean-up and Visual Inspection:

The Contractor shall remove and containerize all lead waste material and visible accumulations of debris, paint chips and associated items.

During clean-up the Contractor shall utilize rags and sponges wetted with lead-specific detergent and water as well as HEPA filtered vacuum equipment.

The Engineer will conduct a visual inspection of the work areas in order to document that all surfaces have been maintained as free as practicable of accumulations of lead in accordance with 29 CFR 1926.62(h). If visible accumulations of waste, debris, lead paint chips or dust are found in the work area, the Contractor shall repeat the cleaning, at the Contractor's expense, until the area is in compliance. The visual inspection will detect incomplete work, damage caused by the abatement activity, and inadequate clean up of the work site.

#### I. Post-Work Regulated Area Deregulation:

Following an acceptable visual inspection, any engineering controls implemented may be removed.

A final visual inspection of the work area shall be conducted by the Competent Person and the Project Monitor or Engineer to ensure that all visible accumulations of suspect materials have been removed and that no equipment or materials associated with the lead paint removal remain.

If this final visual inspection is acceptable, the Contractor will reopen the Regulated Area and remove all signage.

The Contractor shall restore all work areas and auxiliary areas utilized during work to conditions equal to or better than original. Any damage caused during the performance of the work activity shall be repaired by the Contractor at no additional expense to the State.

**J. Waste Disposal/Recycling:**

Non-metallic building debris waste materials tested and found to be non-hazardous Construction and Demolition (C&D) bulky waste shall be disposed of properly at a CTDEEP approved Solid Waste landfill as described under this Item 0020903A.

Metallic debris shall be segregated and recycled as scrap metal at an approved metal recycling facility.

Concrete, brick, etc. coated with any amount of lead paint cannot be crushed, recycled or buried on-site to minimize waste disposal unless tested and found to meet the RSR GA/Residential standards.

Hazardous lead debris shall be disposed of as described under this Item 0020903A.

The Contractor shall comply with the latest requirements of the USEPA RCRA Hazardous Waste Regulations 40 CFR 260-274 and the DEEP Hazardous/Solid Waste Management Standards 22a-449(c).

**Hazardous lead debris shall be transported from the Project by a licensed hazardous waste transporter approved by the Department and disposed of at an EPA-permitted and Department-approved hazardous waste landfill within 90 days from the date of generation.**

The Contractor must use one or more of the following Department-approved disposal facilities for the disposal of hazardous waste:

Clean Earth of North Jersey, Inc., (CENJ) 115 Jacobus Avenue, South Kearny, NJ 07105 Phone: (973) 344-4004; Fax: (973) 344-8652	Clean Harbors Environmental Services, Inc. 2247 South Highway 71, Kimball, NE 69145 Phone: (308) 235-8212; Fax: (308) 235-4307
Clean Harbors of Braintree, Inc. 1 Hill Avenue, Braintree, MA 02184 Phone: (781) 380-7134; Fax: (781) 380-7193	Cycle Chem (General Chemical Corp.) 217 South First Street, Elizabeth, NJ 07206 Phone: (908) 355-5800; Fax (908) 355-0562
EnviroSafe Corporation Northeast (former Jones Environmental Services (NE), Inc.) 263 Howard Street, Lowell, MA 01852 Phone: (978) 453-7772; Fax: (978) 453-7775	Environmental Quality Detroit, Inc. 1923 Frederick Street, Detroit, MI 48211 Phone: (800) 495-6059; Fax: (313) 923-3375

Republic Environmental Systems 2869 Sandstone Drive, Hatfield, PA 19440 Phone: (215) 822-8995; Fax: (215) 997-1293	Northland Environmental, Inc. (PSC Environmental Systems) 275 Allens Avenue, Providence, RI 02905 Phone: (401) 781-6340; Fax: (401) 781-9710
Environmental Quality Company: Wayne Disposal Facility 49350 North I-94 Service Drive Belleville, MI 48111 Phone: (800) 592-5489; Fax: (800) 592-5329	

No facility may be substituted for the one(s) designated in the Contractor's submittal without the Engineer's prior approval. If the material cannot be accepted by any of the Contractor's designated facilities, the Department will supply the Contractor with the name(s) of other acceptable facilities.

**Prior to the generation of any hazardous waste**, the Contractor shall notify the Engineer of its selected hazardous waste transporter and disposal facility. The Contractor must submit to the Engineer (1) the transporter's current US DOT Certificate of Registration and (2) the transporter's current Hazardous Waste Transporter Permits for the State of Connecticut, the hazardous waste destination state and any other applicable states. The Engineer will then obtain on a contiguous per site basis a temporary EPA Generators ID number for the site that he will forward to the Contractor. Any changes in transporter or facility shall be immediately forwarded to the Engineer for review.

Handling, storage, transportation and disposal of hazardous waste materials generated as a result of execution of this project shall comply with all Federal, State and Local regulations including the USEPA RCRA Hazardous Waste Regulations (40 CFR Parts 260-271), the CTDEEP Hazardous Waste Regulations (22a-209 and 22a-449(c)), and the USDOT Hazardous Materials Regulations (49 CFR Part 171-180).

All debris shall be contained and collected daily or more frequently as directed by the Engineer, due to debris buildup. Debris shall be removed by HEPA vacuum collection. Such debris and paint chips shall be stored in leak-proof storage containers in the secured storage site, or as directed by the Engineer. The storage containers and storage locations shall be reviewed by the Engineer and shall be located in areas not subject to ponding. Storage containers shall be placed on pallets and closed and covered with tarps at all times except during placement, sampling and disposal of the debris.

Hazardous waste materials are to be properly packed and labeled for transport by the Contractor in accordance with EPA, CTDEEP and USDOT regulations. The disposal of debris characterized as hazardous waste shall be completed within 90 calendar days of the date on which it began to be accumulated in the lined containers. Storage of containers shall be in accordance with current DEEP/EPA procedures.

The Contractor shall label hazardous waste storage containers with a 6-inch square, yellow, weatherproof, Hazardous Waste sticker in accordance with USDOT regulations.



Materials other than direct paint related debris which are incidental to the paint removal work activities (tarps, poly, plywood, PPE, gloves, decontamination materials, etc.) which may be contaminated with lead, shall be stored separately from the direct paint debris, and shall be sampled by the Engineer for waste disposal characterization testing. Such materials characterized as hazardous shall be handled/disposed of as described herein, while materials characterized as non-hazardous shall be disposed of as non-hazardous CTDEEP Solid Waste.

Direct paint related debris materials not previously sampled and characterized for disposal, which may be originally presumed to be hazardous waste, shall also be stored separately and sampled by the Engineer for ultimate waste disposal characterization testing and handled/disposed of based on that testing.

Project construction waste materials unrelated to the paint removal operations shall NOT be combined/stored with paint debris waste and/or incidental paint removal materials as they are not lead contaminated and shall NOT be disposed of as hazardous waste. The Engineer's on-site Inspectors shall conduct inspections to verify materials remain segregated.

The Contractor shall obtain and complete all paperwork necessary to arrange for material disposal, including disposal facility waste profile sheets. It is solely the Contractor's responsibility to co-ordinate the disposal of hazardous materials with its selected treatment/recycling/disposal facility(s). Upon receipt of the final approval from the facility, the Contractor shall arrange for the loading, transport and treatment/recycling/disposal of the materials in accordance with all Federal and State regulations. **No claim will be considered based on the failure of the Contractor's disposal facility(s) to meet the Contractor's production rate or for the Contractor's failure to select sufficient facilities to meet its production rate.**

The Contractor shall process the hazardous waste such that the material conforms with the requirements of the selected treatment/disposal facility, including but not limited to specified size and dimension. Refusal on the part of the treatment/disposal facility to accept said material solely on the basis of non-conformance of the material to the facility's physical requirements is the responsibility of the Contractor and no claim for extra work shall be accepted for reprocessing of said materials to meet these requirements.

All DOT shipping documents, including the Uniform Hazardous Waste Manifests utilized to accompany the transportation of the hazardous waste material shall be prepared by the Contractor and reviewed/signed by an authorized agent representing ConnDOT, as Generator, for each load of hazardous material that is packed to leave the site. The Contractor shall not sign manifests on behalf of the State as Generator. The Contractor shall forward the appropriate original copies of all manifests to the Engineer the same day the material leaves the Project site.

Materials not related to lead paint removal and/or characterized as non-hazardous waste shall NOT be shipped for hazardous waste disposal in accordance with USEPA RCRA hazardous waste minimization requirements.

A load-specific certificate of disposal, signed by the authorized agent representing the waste disposal facility, shall be obtained by the Contractor and promptly delivered to the Engineer for each load.

In addition to all pertinent Federal, State and local laws or regulatory agency polices, the Contractor shall adhere to the following precautions during the transport of hazardous materials off-site:

- All vehicles departing the site are to be properly logged to show the vehicle identification, driver's name, time of departure, destination, and approximate volume, and contents of materials carried. Vehicles shall display the proper USDOT placards for the type and quantity of waste;
- No materials shall leave the site unless a disposal facility willing to accept all of the material being transported has agreed to accept the type and quantity of waste;
- Documentation must be maintained indicating that all applicable laws have been satisfied and that the materials have been successfully transported and received at the disposal facility; and,
- The Contractor shall segregate the waste streams (i.e. concrete, wood, etc.) as directed by the receiving disposal facility.

Any spillage of debris during disposal operations during loading, transport and unloading shall be cleaned up in accordance with EPA 40 CFR 265 Subparts C & D, at the Contractor's expense.

The Contractor is liable for any fines, costs or remediation costs incurred as a result of their failure to be in compliance with this Item and all Federal, State and Local laws.

#### K. Project Closeout Data:

Provide the Engineer, within thirty (30) days of completion of the project site work, a compliance package; which shall include, but not be limited to, the following:

1. Competent persons (supervisor) job log;
2. OSHA-compliant personnel air sampling data;
3. Completed waste shipment papers for non-hazardous lead construction and demolition (C&D) waste disposal or recycling and scrap metal recycling.
4. Copies of completed Hazardous Waste Manifests (signed by authorized disposal facility representative).

#### **Method of Measurement:**

The completed work shall be paid as a lump sum. This item will include all noted services, equipment, facilities, testing and other associated work for up to three (3) ConnDOT project

representatives. Services provided to any ConnDOT project representatives in excess of three (3) representatives will be measured for payment in accordance with Article 1.09.04 – “Extra and Cost-Plus Work.”

**Basis of Payment:**

The lump sum price bid for this item shall include: services, materials, equipment, all permits, notifications, submittals, personal air sampling, personal protection equipment, temporary enclosures, incidentals, fees and labor incidental to activities impacting lead removal, treatment and handling of lead contaminated materials, and the transport and disposal of any hazardous and/or non-hazardous, non-RCRA lead waste.

Final payment will not be made until all project closeout data submittals have been completed and provided to the Engineer. Once the completed package has been received in its entirety and accepted by the Engineer, final payment will be made to the Contractor.

<u>Pay Item</u>	<u>Pay Unit</u>
Lead Compliance for Miscellaneous Exterior Tasks	Lump Sum

END OF SECTION

## **ITEM #0219011A – SEDIMENTATION CONTROL AT CATCH BASIN**

**Description:** This work shall consist of furnishing, installing, cleaning, maintaining, replacing, and removing sedimentation control at catch basins at the locations and as shown on plans and as directed by the engineer.

### **Materials**

Sack shall be manufactured from a specially designed woven polypropylene geotextile sewn by a double needle machine, using a high strength nylon thread. Sack shall be manufactured by the following or an approved equal:

Siltsack®

SI Geosolutions:

[www.sigeosolutions.com](http://www.sigeosolutions.com)

(800)621-0444

The sack will be manufactured to fit the opening of the catch basin or drop inlet. Sack will have the following features: two dump straps attached at the bottom to facilitate the emptying of sack and lifting loops as an integral part of the system to be used to lift sack from the basin. The sack shall have a restraint cord approximately halfway up the sack to keep the sides away from the catch basin walls, this cord is also a visual means of indicating when the sack should be emptied. Once the strap is covered with sediment, the sack should be emptied, cleaned and placed back into the basin.

### **Construction Methods:**

Installation, removal, and maintenance shall be per manufacturer instructions and recommendations.

**Method of Measurement:** Sedimentation Control at Catch Basin will be measured as each installed, maintained, accepted, and removed. There will be no separate measurement for maintenance or replacement associated with this item.

### **Basis of Payment:**

Sedimentation Control at Catch Basin will be paid for at the contract unit price each complete in place and accepted, which price shall include all maintenance throughout construction, disposal of debris, materials, equipment, tools, and labor incidental thereto.

**ITEM #0404101A—BITUMINOUS CONCRETE PATCHING - PARTIAL DEPTH**

**Description:** This work shall consist of sawcutting, removing and properly disposing of deteriorated bituminous concrete pavement, regrading and recompacting the existing granular base, cleaning and application of tack coat on the vertical faces of the sawcut, and placement of Hot-Mix Asphalt (HMA) or an equivalent Polymer Modified Asphalt (PMA) at the same thickness as surrounding pavement, (minimum 6 inches), and as shown on the plans.

**Materials:** Materials for this work shall meet the requirements of Section M.04 and shall consist of the following:

1. HMA S0.5, HMA S0.375 (when requested by the Contractor and approved by the Engineer at least 5 days in advance) or an equivalent PMA. All HMA, or PMA, shall be Traffic Level 2 unless indicated otherwise on the plans.
2. Tack coat.

**Construction Methods:** Equipment for this work shall include pavement cutting, removal, material handling, and small compaction equipment to perform all patching operations. The Contractor shall also provide a 10 foot straightedge. If the work is performed at night a portable truck towed light tower and driver shall be provided for use by the Engineer for all marking, installation and inspection of the patches.

All equipment used to place and compact the HMA, or PMA, shall meet the requirements of Section 4.06. Due to the nature of this work, the equipment shall be small to medium size to fit excavated areas to be patched. It is also expected that placement of HMA, or PMA, will require hand work or a combination of equipment and hand work methods and tools to achieve the required results.

1. The Engineer will mark out areas for patching. The minimum dimension of areas to be patched shall be 24 inches. Any area to be patched shall completely encompass the entire distressed pavement area and extend at least 6 inches beyond into the surrounding pavement wherever possible.
2. If it is determined that poor or inadequate granular base is contributing to the distress in the asphalt layers, the Engineer may direct that it be removed and processed aggregate be placed and compacted.
3. Sawcut at the marked areas through the full depth of the bituminous concrete pavement.
4. Remove existing pavement from within the sawcut minimizing disturbance of the existing granular base.
5. Regrade the existing granular base and recompact it using jumping jack or vibratory plate compactors. A minimum of 4 passes, or coverages, must be made by the compaction device. If existing granular base material is lost during the excavation of the deteriorated pavement, the Contractor shall add material meeting the requirements of Section 3.04. Compaction of the granular base material shall meet the density requirements of Section 3.04.

6. The cut sides/walls of the excavated area shall be wiped or swept clean, tack coat shall be applied covering the entire area of the vertical bituminous concrete faces and allowed to cure or break.
7. HMA S0.5, or PMA S0.5, shall be placed in lifts between 2 inches and 3 inches, shall have a final lift thickness placed at 2 inches and be placed as shown in the plans. HMA S0.375, or PMA S0.375, shall be placed in lifts between 1.5 inches and 2.5 inches, shall have a final lift thickness placed at 1.5 inches and be placed as shown in the plans. Pavement placement shall also be in accordance with Subarticle 4.06.03-6. The Contractor shall confirm that the surface elevation of the finished patch matches the elevation of the surrounding pavement surface to within 1/4 inch using the 10 foot straightedge.
8. All excavated materials shall be properly disposed of at the end of the work shift.

**Method of Measurement:** This work will be measured by the number of square yards of patched bituminous concrete completed and accepted.

**Basis of Payment:** This work will be paid for at the Contract unit price per square yard for “Bituminous Concrete Patching - Partial Depth” completed and accepted. The price shall include all tools, materials, labor and equipment, including sawcutting, pavement removal and disposal, grading and compaction of existing granular base, cleaning, tack coat application, HMA, or PMA, placement and compaction.

There will be no additional compensation for replacing granular base material lost during the excavation of the deteriorated pavement.

Inadequate or poor granular base foundations that cannot be recompacted as determined by the Engineer will be paid for at the Contract unit price per cubic yard of “Processed Aggregate Base.”

Pay Item	Pay Unit
Bituminous Concrete Patching - Partial Depth	s.y.

## **ITEM #0406195A – FILLING JOINTS AND CRACKS IN BITUMINOUS CONCRETE PAVEMENT**

**Description:** This work consists of furnishing and applying a hot-applied mixture of Performance Graded (PG) asphalt binder and polyester fibers into bituminous concrete pavement joints and cracks. It shall be constructed in close conformity with the lines, grades, thicknesses, and typical cross sections shown on the plans or established by the Engineer. Filling Joints and Cracks in Bituminous Concrete Pavement may be used in conjunction with other repair treatments including, but not limited to, joint and crack sealing or patching, in which case the sequence of treatments will be provided in the Contract Documents or directed by the Engineer.

For the purposes of this document, the word “crack” includes all longitudinal (along the direction of travel) and transverse (perpendicular to the direction of travel) cracks and joints. All work specified for “crack(s)” herein shall apply to all types of cracks and joints unless otherwise specified.

**Materials:** The hot-applied crack filling material shall be composed of a mixture of Performance Graded Asphalt Binder and polyester fibers blended to provide 4.5% to 5.5% fibers by weight. No field mixing of the fibers is allowed. The crack filling material (with fibers) shall be prepackaged and arrive on Site ready to be placed in the melter applicator. The component materials shall meet the following requirements:

1. Polyester Fibers: A Materials Certificate shall be provided by the manufacturer for this material. The polyester fibers must meet the following requirements:

<b>Property</b>	<b>Test Method</b>	<b>Requirement</b>
Length	N/A	0.25 inch ± 2 mils (6.4mm ± 0.05mm)
Crimps	ASTM D3937	None
Tensile Strength*	ASTM D2256	69,600 psi (480 MPa), minimum
Denier*	ASTM D1577	3.0 – 6.0
Specific Gravity	N/A	1.32 – 1.40
Melting Temperature	N/A	473°F (245°C), minimum
Ignition Temperature	N/A	1000°F (540°C), minimum

\* This data must be obtained prior to cutting the fibers.

2. Performance Graded (PG) Asphalt Binder: The Performance Graded (PG) Asphalt Binder shall be PG 64E-22 (PG 76-22) and shall meet the requirements of AASHTO M 320(M) and AASHTO R 29(M). The Contractor shall submit a Certified Test Report and bill of lading representing each delivery in accordance with AASHTO R 26(M). The Certified Test Report must also indicate the asphalt binder specific gravity at 77°F, rotational viscosity at 275°F and 329°F, and a mixing and compaction viscosity-temperature chart as if the asphalt binder were to be used as binder for the construction of hot mix asphalt. The blending of PG asphalt binder from different suppliers is strictly prohibited. Contractors who blend PG asphalt

binders will be classified as a "Supplier" and will be required to certify the asphalt binder in accordance with AASHTO R 26(M).

3. Optional Barrier Material - Clean, Dry Sand: Sand shall conform to the requirements of Standard Specification Article M.01.03, Fine Aggregates, except that the gradation requirements shall be replaced with the following:

Square Mesh Sieve	Percent Passing by Weight
No. 8	100
No. 50	10 – 40
No. 100	0 – 10
No. 200	0 – 3

The Contractor must submit to the Engineer all Material Safety Data Sheet and Certified Test Report documents from the material manufacturer(s) prior to the commencement of work. During work progress, the Contractor must submit to the Engineer the manufacturer's Material Certificate for compliance to applicable specifications for each batch or lot of material used on the Contract.

**Equipment:** The equipment used by the Contractor shall include, but not be limited to, the following:

1. Melter Applicator: The unit shall consist of a boiler kettle equipped with pressure pump, hose, and applicator wand; the boiler kettle may be a combination melter and pressurized applicator of a double-boiler type with space between the inner and outer shells filled with heat transfer oil. Heat transfer oil shall have a flash point of not less than 600°F. The kettle shall include a temperature control indicator. The kettle shall be capable of maintaining the crack fill material at the manufacturer's specified application temperature range. The kettle shall include an insulated applicator hose and application wand. The hose shall be equipped with a shutoff control. The kettle shall include a mechanical fullsweep agitator to provide continuous blending. The unit shall be equipped with thermometers to monitor the material temperature and the heating oil temperature. The unit shall be equipped with thermostatic controls that allow the operator to regulate material temperature up to at least 425°F.
2. Application Wand and Squeegee Applicator: The material shall be applied with a wand followed by a squeegee applicator. The squeegee applicator shall be of commercial/industrial quality designed with a "U" shaped configuration. It shall be of a size adequate to strike off, flush with the surrounding pavement surface and without overflow around the sides, all crack fill material placed. This tool shall be either attached to the applicator wand or used separately as its own long handled tool.
3. Hot Air Lance: The unit shall be designed for cleaning and drying the pavement surface cracks. Minimum compressed air capacity shall be 100 psi. The compressed air emitted from the tip of the lance shall be capable of achieving a temperature of at least 1500°F.



4. Vertically Mounted Power Driven Wire Brush: This tool shall be used to remove any dirt, debris, or vegetation to the depths specified that cannot be removed by the hot air lance. It shall be of adequate size and power to remove all material from cracks as specified.

**Construction Methods:** The crack filling operation shall proceed in accordance with the requirements of the “Maintenance and Protection of Traffic” and “Prosecution and Progress” specifications.

1. Weather Requirements: Work shall not be performed unless the pavement is dry. No frost, snow, ice, or standing water may be present on the roadway surface or within the cracks. The ambient temperature must be 40°F and rising during field application operations for work to proceed.
2. Material Mixing Procedure: The prepackaged material shall be added to the melter applicator in the presence of the Engineer. It shall then be mixed and heated to the recommended application temperature. The crack fill material shall never exceed 400°F.
3. Determination of Cracks to be Filled: The width and depth requirements for cracks to be filled are as follows:

All crack width determinations shall be made by measuring the crack width flush at the surface of the pavement prior to being filled. A straightedge shall be used whenever necessary to establish the location or limits of the flush surface of the pavement.

All cracks from  $\frac{1}{8}$  inch up to 1.5 inches wide shall be prepared and filled as stated below. Cracks that are between  $\frac{1}{8}$  inch and 1.5 inches wide, but eventually taper in width below the minimum  $\frac{1}{8}$  inch, shall also be prepared and filled as stated below. Only cracks that are less than  $\frac{1}{8}$  inch wide throughout their entire length shall be excluded.

Transverse cracks, where a portion of the crack (50% or less) exceeds a width of 1.5 inches, up to 2 inches, shall also be prepared and filled as stated below.

All joints to be filled that are raveled (loss of the pavement surface material) shall be at least  $\frac{1}{2}$  inch in depth at the joint's deepest point. The minimum width of a raveled joint must be  $\frac{1}{2}$  inch. The maximum width of a raveled joint to be filled is 3 inches.

Any cracks exceeding the width and depth requirements specified above shall be repaired using separate items.

4. Crack Preparation: Cracks to be filled shall be treated with a hot air lance prior to application of the crack fill material. Two (2) passes minimum shall be made with the hot air lance. The hot air lance operation shall proceed at a rate no greater than 120 feet per minute. There shall be no more than 10 minutes between the second hot air lance treatment and the material application. Should this time be exceeded, additional pass(es) shall be made with the hot air lance.

The use of the hot air lance is not intended to heat the crack. It is to be used to blow all debris from the crack to the depths specified below and to remove any latent moisture from the crack until the inside of the crack is completely dry as determined by the Engineer. "Moisture" does not include standing water. The hot air lance is not to be used to boil off or blow standing water from the bottom of a crack. If standing water is present in the bottom of any crack, the filling operation shall be postponed until such time that the standing water evaporates naturally. The Contractor may use compressed, oil-free air (not heated) to blow standing water from a crack to help accelerate the natural evaporation process. If standing water remains after using compressed air, the crack shall be allowed to dry naturally until remaining standing water evaporates. The hot air lance may be used after visible water has evaporated. If a crack is already completely dry as determined by the Engineer, the hot air lance shall be operated at its lowest temperature possible.

The hot air lance shall be used to blow all debris from cracks (not including raveled joints) to a depth of at least  $\frac{3}{4}$  inch for cracks between  $\frac{1}{8}$  inch and  $\frac{3}{4}$  inch wide, and to a depth of 1.25 inches for cracks between  $\frac{3}{4}$  inch and 2 inches wide. The hot air lance shall be used to blow all debris from raveled joints to a depth of 1 inch or the full depth of the joint, whichever is smaller.

In the event that cracks are packed tightly with debris, dirt, vegetation, or other material, except previously placed sealant or filler, the Contractor shall use a vertically mounted power driven wire brush to remove all material and burnish the sides of the crack to the depths specified above. Cracks treated with the power driven wire brush shall subsequently be treated with a hot air lance as described in this section. The use of both the power driven wire brush and the hot air lance shall result in the complete removal of all material in the crack (except previously placed sealant or filler) to the depths specified above such that the sides of the crack are completely free and clean of any debris and moisture.

In the event that cracks have depths greater than 2 inches below the pavement surface, the Contractor may place a barrier composed of clean, dry sand as specified herein. The barrier material shall be placed in a manner leaving 1.25 inches below the elevation of the pavement surface for crack filling material. A barrier will not be allowed for cracks wider than 1.5 inches or less than  $\frac{1}{2}$  inch wide.

5. Crack Filling: As soon as cracks have been prepared, they shall be filled to refusal along their entire length. The treatment material shall be maintained at the manufacturer's specified/recommended application temperature range at all times. The filling operation shall be suspended if the temperature of the crack filling material falls outside the specified temperature range and shall remain suspended until the crack filling material is brought within the specified temperature range. Filled cracks are to be squeegeed immediately following application of the crack filling material, striking excess filler flat to the adjacent pavement surface. There shall be no build-up of treatment material above or adjacent to the crack at any time. If the initial application of crack fill material fails to fill the crack or

shrinks upon cooling such that there is a depression formed of at least ¼ inch or greater, a second application of filler shall be placed over the first application.

6. Protection of Filled Cracks: Traffic shall not be permitted on the pavement until the crack fill material is set so that the material does not track and is not deformed or pulled out by tires. If the work under this item is being performed prior to placing a hot mix overlay or other surface treatment, a detackifier or blotting agent will not be allowed. If work under this item is not followed by placement of an overlay of any kind, a detackifier or blotting agent may be used. If a detackifier or blotting agent is used, it shall be one recommended by the supplier of the crack filling material and shall be used as recommended by the supplier, except that no paper, cotton, or other organic materials shall be allowed. Information on the type and usage of a detackifier or blotting agent shall be presented to the Engineer for their written acceptance prior to use.
7. Removal and Disposal of Material: All debris generated from the operations described above shall be removed from the roadway by the Contractor.

Treatment material remaining in the Contractor's kettle at the close of the daily work session shall be discarded. At no time shall treatment material be re-heated for use in subsequent crack filling applications unless permitted by the Engineer following a review of specific circumstances.

All debris and surplus treatment material shall be properly disposed in accordance with Article 1.10.03 and State of Connecticut law.

**Acceptance of Work:** When the work is complete, an inspection shall be scheduled with the Engineer. The Engineer will note all deficiencies including, but not limited to, areas exhibiting adhesion failure, cohesion failure, tracking of filler material, and missed cracks. Work identified by the Engineer as not acceptable shall be repaired at the Contractor's expense. The Contractor shall notify the Engineer upon completion of any corrective work performed.

**Method of Measurement:** This work shall be measured by the total number of linear feet of cracks filled as indicated in the Contract plans and as measured, verified, and accepted by the Engineer.

**Basis of Payment:** This work shall be paid for at the Contract unit price per linear foot for "Filling Joints and Cracks in Bituminous Concrete Pavement" complete and accepted in place. The price shall include all submittals, materials, equipment, tools, and labor incidental thereto. No payment will be made to the Contractor prior to submittal of required documents.

Pay Item	Pay Unit
Filling Joints and Cracks in Bituminous Concrete Pavement	l.f.

**ITEM #0406275A - FINE MILLING OF BITUMINOUS CONCRETE (0 TO 4 INCHES)**

**Description:** This work shall consist of the milling, removal, and disposal of existing bituminous concrete pavement.

**Construction Methods:** The Contractor shall remove the bituminous concrete material using means acceptable to the Engineer. The pavement surface shall be removed to the line, grade, and existing or typical cross-section shown on the plans or as directed by the Engineer.

The bituminous concrete material shall be disposed of offsite by the Contractor at an approved disposal facility unless otherwise stated in the Contract.

Any milled surface, or portion thereof, that is exposed to traffic shall be paved within five (5) calendar days unless otherwise stated in the plans or Contract.

The equipment for milling the pavement surface shall be designed and built for milling bituminous concrete pavements. It shall be self propelled with sufficient power, traction, and stability to maintain depth and slope and shall be capable of removing the existing bituminous concrete pavement.

The milling machine shall be equipped with a built-in automatic grade averaging control system that can control the longitudinal profile and the transverse cross-slope to produce the specified results. The longitudinal controls shall be capable of operating from any longitudinal grade reference, including string line, contact ski (30 feet minimum), non-contact ski (20 feet minimum), or mobile string line (30 feet minimum). The transverse controls shall have an automatic system for controlling cross-slope at a given rate. The Engineer may waive the requirement for automatic grade or slope controls where the situation warrants such action.

The machine shall be able to provide a 0 to 4 inch deep cut in one pass. The rotary drum of the machine shall use carbide or diamond tipped tools spaced not more than  $\frac{5}{16}$  inch apart. The forward speed of the milling machine shall be limited to no more than 45 feet/minute. The tools on the revolving cutting drum must be continually maintained and shall be replaced as warranted to provide a uniform pavement texture.

The machine shall be equipped with an integral pickup and conveying device to immediately remove material being milled from the surface of the roadway and discharge the millings into a truck, all in one operation. The machine shall also be equipped with a means of effectively limiting the amount of dust escaping from the milling and removal operation.

When milling smaller areas or areas where it is impractical to use the above described equipment, the use of a lesser equipped milling machine may be permitted when approved by the Engineer.

Protection shall be provided around existing catch basin inlets, manholes, utility valve boxes, and any similar structures. Any damage to such structures as a result of the milling operation is the Contractor's responsibility and shall be repaired at the Contractor's expense.

To prevent the infiltration of milled material into the storm drainage system, the Contractor shall take special care to prevent the milled material from falling into the inlet openings or inlet grates. Any milled material that has fallen into inlet openings or inlet grates shall be removed at the Contractor's expense.

**Surface Tolerance:** The milled surface shall provide a satisfactory riding surface with a uniform textured appearance. The milled surface shall be free from gouges, longitudinal grooves and ridges, oil film, and other imperfections that are a result of defective equipment, improper use of equipment, or poor workmanship. The Contractor, under the direction of the Inspector, shall perform random spot-checks with a Contractor supplied ten-foot straightedge to verify surface tolerances at a minimum of five (5) locations per day. The variation of the top of two ridges from the testing edge of the straightedge, between any two ridge contact points, shall not exceed ¼ inch. The variation of the top of any ridge to the bottom of the groove adjacent to that ridge shall not exceed ¼ inch. Any unsatisfactory surfaces produced are the responsibility of the Contractor and shall be corrected at the Contractor's expense and to the satisfaction of the Engineer.

The depth of removal will be verified by taking measurements every 250 feet per each pass of the milling machine, or as directed by the Engineer. These depth measurements shall be used to monitor the average depth of removal.

Where a surface delamination between bituminous concrete layers or a surface delamination of bituminous concrete on Portland cement concrete causes a non-uniform texture to occur, the depth of milling shall be adjusted in small increments to a maximum of +/- ½ inch to eliminate the condition.

When removing bituminous concrete pavement entirely from an underlying Portland cement concrete pavement, all of the bituminous concrete pavement shall be removed leaving a uniform surface of Portland cement concrete, unless otherwise directed by the Engineer.

Any unsatisfactory surfaces produced by the milling operation are the Contractor's responsibility and shall be corrected at the Contractor's expense and to the satisfaction of the Engineer.

No vertical faces, transverse or longitudinal, shall be left exposed to traffic unless the requirements below are met. This shall include roadway structures (catch basins, manholes, utility valve boxes, etc.). If any vertical face is formed in an area exposed to traffic, a temporary paved transition shall be established according to the requirements shown on the plans. If the milling machine is used to form a temporary transition, the length of the temporary transition shall conform to Special Provision Section 4.06 –Bituminous Concrete, "Transitions for Roadway Surface," the requirements shown on the plans, or as directed by the Engineer. At all

permanent limits of removal, a clean vertical face shall be established by saw cutting prior to paving.

Roadway structures shall not have a vertical face of greater than one (1) inch exposed to traffic as a result of milling. All structures within the roadway that are exposed to traffic and greater than one (1) inch above the milled surface shall receive a transition meeting the following requirements:

For roadways with a posted speed limit of 35 mph or less\*:

1. Round structures with a vertical face of greater than 1 inch to 2.5 inches shall be transitioned with a hard rubber tapered protection ring of the appropriate inside diameter designed specifically to protect roadway structures.
2. Round structures with a vertical face greater than 2.5 inches shall receive a transition of bituminous concrete formed at a minimum 24 to 1 (24:1) taper in all directions.
3. All rectangular structures with a vertical face greater than 1 inch shall receive a transition of bituminous concrete formed at a minimum 24 to 1 (24:1) taper in all directions.

\*Bituminous concrete tapers at a minimum 24 to 1 (24:1) taper in all directions may be substituted for the protection rings if approved by the Engineer.

For roadways with a posted speed limit of 40, 45 or 50 mph:

1. All structures shall receive a transition of bituminous concrete formed at a minimum 36 to 1 (36:1) taper in the direction of travel. Direction of travel includes both the leading and trailing side of a structure. The minimum taper shall be 24 to 1 (24:1) in all other directions.

For roadways with a posted speed limit of greater than 50 mph:

1. All structures shall receive a transition of bituminous concrete formed at a minimum 60 to 1 (60:1) taper in the direction of travel. Direction of travel includes both the leading and trailing side of a structure. The minimum taper shall be 24 to 1 (24:1) in all other directions.

All roadway structure edges and bituminous concrete tapers shall be clearly marked with fluorescent paint. The paint shall be maintained throughout the exposure to traffic.

The milling operation shall proceed in accordance with the requirements of the "Maintenance and Protection of Traffic" and "Prosecution and Progress" specifications, or other Contract requirements. The more stringent specification shall apply.

Prior to opening an area which has been milled to traffic, the pavement shall be thoroughly swept with a sweeper truck. The sweeper truck shall be equipped with a water tank and be capable of removing the millings and loose debris from the surface. The sweeper truck shall operate at a forward speed that allows for the maximum pickup of millings from the roadway surface. Other sweeping equipment may be provided in lieu of the sweeper truck where acceptable by the Engineer.

Any milled area that will not be exposed to live traffic for a minimum of 48 hours prior to paving shall require a vacuum sweeper truck in addition to, or in lieu of, mechanical sweeping. The vacuum sweeper truck shall have sufficient power and capacity to completely remove all millings from the roadway surface including any fine particles within the texture of the milled surface. Vacuum sweeper truck hose attachments shall be used to clean around pavement structures or areas that cannot be reached effectively by the main vacuum. Compressed air may be used in lieu of vacuum attachments if approved by the Engineer.

**Method of Measurement:** This work will be measured for payment by the number of square yards of area from which the milling of asphalt has been completed and the work accepted. No area deductions will be made for minor unmilled areas such as catch basin inlets, manholes, utility boxes and any similar structures.

**Basis of Payment:** This work will be paid for at the Contract unit price per square yard for “Fine Milling of Bituminous Concrete (0 to 4 Inches).” This price shall include all equipment, tools, labor, and materials incidental thereto.

No additional payments will be made for multiple passes with the milling machine to remove the bituminous surface.

No separate payments will be made for cleaning the pavement prior to paving; providing protection and doing handwork removal of bituminous concrete around catch basin inlets, manholes, utility valve boxes and any similar structures; repairing surface defects as a result of the Contractors negligence; providing protection to underground utilities from the vibration of the milling operation; removal of any temporary milled or paved transition; removal and disposal of millings; furnishing a sweeper truck and sweeping after milling. The costs for these items shall be included in the Contract unit price.

Pay Item	Pay Unit
Fine Milling of Bituminous Concrete (0 to 4 Inches)	S.Y.

## **ITEM #0520036A - ASPHALTIC PLUG EXPANSION JOINT SYSTEM**

**Description:** Work under this item shall consist of furnishing and installing an asphaltic plug expansion joint system (APJ) in conformance with ASTM D6297, as shown on the plans, and as specified herein.

Work under this item shall also consist of the removal and disposal of bituminous concrete, membrane waterproofing, existing joint components and sealing elements, cleaning and sealing median barrier joints, parapet joints, and sidewalk joints.

Work under this item excludes the removal of Portland cement concrete headers.

**Materials:** The APJ component materials shall conform to ASTM D6297 and the following:

Aggregate: The aggregate shall meet the following requirements:

- a) Loss on abrasion: The material shall show a loss on abrasion of not more than 25% using AASHTO Method T96.
- b) Soundness: The material shall not have a loss of more than 10% at the end of five cycles when tested with a magnesium sulfate solution for soundness using AASHTO Method T 104.
- c) Gradation: The aggregate shall meet the requirements of Table A below:
- d) Dust: aggregate shall not exceed 0.5% of dust passing the #200 sieve when tested in accordance with AASHTO T-11.

**Table A**

<b><u>Square Mesh Sieves</u></b>	<b>1" (25.0 mm)</b>	<b>¾" (19.0 mm)</b>	<b>½" (12.5 mm)</b>	<b>⅜" (9.5 mm)</b>	<b>No. 4 (4.75 mm)</b>
<b>% passing</b>	<b>100</b>	<b>90 - 100</b>	<b>20 - 55</b>	<b>0 - 15</b>	<b>0 - 5</b>

A sample of the aggregate shall be submitted to the Department with a Certified Test Report in accordance with Article 1.06.07 for each 20 tons of loose material or its equivalent number of bags delivered to the job site. The Certified Test report must include a gradation analysis resulting from a physical test performed on the actual material that accompanies the report.

Anti-Tacking Material: This material shall be a fine graded granular material with 100% passing the 3/16" sieve and no more than 5% passing the #200 when tested in accordance with AASHTO T-27.

Backer Rod: All backer rods shall satisfy the requirements of ASTM D5249, Type 1.

Bridging Plate: The bridging plates shall be steel conforming to the requirements of ASTM A36 and be a minimum ¼" thick and 8" wide. For joint openings in excess of 3" the minimum



plate dimensions shall be  $\frac{3}{8}$ " thick by 12" wide. Individual sections of plate shall not exceed 4' in length. Steel locating pins for securing the plates shall be size 16d minimum, hot-dip galvanized, and spaced no more than 12" apart.

**Concrete Leveling Material:** Shall be a cementitious-based material that conforms to ASTM C928 Standard Specification for Packaged, Dry, Rapid-Hardening Cementitious Materials for Concrete Repair, for R3 performance requirements in Table 1 and achieve the following:

- a. Final set in 45 Minutes
- b. 2500 psi compressive strength in 24 hours
- c. 5000 psi compressive strength in 7 days

**Parapet Sealant:** The sealant used in parapet joint openings shall be a single component non-sag silicone sealant that conforms to the requirements of ASTM D5893.

**Sidewalk Sealant:** The sealant used in sidewalk joint openings shall be a rapid cure, self-leveling, cold applied, two-component silicone sealant. The silicone sealant shall conform to the requirements listed in Table B:

**Table B**

<b>Properties - As Supplied</b>	<b>Test Method</b>	<b>Requirement</b>
Extrusion Rate	ASTM C1183	200-600 grams/min
Leveling	ASTM C639	Self-Leveling
Specific Gravity	ASTM D792	1.20 to 1.40
<b>Properties - Mixed</b>	<b>Test Method</b>	<b>Requirement</b>
Tack Free Time	ASTM C679	60 min. max.
Joint Elongation – Adhesion to concrete	ASTM D5329 <sup>1,2,3</sup>	600% min
Joint Modulus @ 100% elongation	ASTM D5329 <sup>1,2,3</sup>	15 psi max
Cure Evaluation	ASTM D5893	Pass @ 5 hours

1. Specimens cured at 77 $\pm$ 3<sup>0</sup>F and 50 $\pm$ 5% relative humidity for 7 days
2. Specimens size:  $\frac{1}{2}$ "wide by  $\frac{1}{2}$ "thick by 2" long
3. Tensile Adhesion test only

The date of manufacture shall be provided with each lot. No sealant shall be used beyond its maximum shelf-life date.

The two-part silicone sealants shown in Table C are known to have met the specified requirements:

**Table C**

<b>Product</b>	<b>Supplier</b>
Dow Corning 902RCS	Dow Corning Corporation 2200 W Salzburg Road Auburn, Michigan 48611
Wabo SiliconeSeal	BASF/Watson Bowman Acme Corporation 95 Pineview Drive Amherst, New York 14228

Other two-component silicone joint sealants expressly manufactured for use with concrete that conform to the aforementioned ASTM requirements will be considered for use provided they are submitted in advance for approval to the Engineer. Other joint sealants will be considered for use only if a complete product description is submitted, as well as documentation describing at least five installations of the product. These documented installations must demonstrate that the product has performed successfully for at least three years on similar bridge expansion joint applications.

A Materials Certificate and Certified Test Report for the asphaltic binder shall be submitted by the Contractor in accordance with the requirements of Article 1.06.07 certifying that the asphaltic binder satisfies the requirements of the most current version of ASTM D6297.

A Materials Certificate for all other components of the APJ, leveling material, backer rod and sealant used in sealing parapet and sidewalk joint openings, shall be submitted by the Contractor in accordance with the requirements of Article 1.06.07

**Construction Methods:** The APJ shall be installed at the locations shown on the plans and in stages in accordance with the traffic requirements in the special provisions “Maintenance and Protection of Traffic” and “Prosecution and Progress”.

At least 30 days prior to start of the work, the Contractor shall submit to the Engineer for approval a detailed Quality Control Plan for the installation of the APJ. The submittal shall include:

- a) A list of all manufactured materials and their properties to be incorporated in the joint system, including, but not limited to the asphaltic binder, anti-tack material, backer rod, sealant, leveling material, as well as the aggregate’s source.
- b) A detailed step by step installation procedure and a list of the specific equipment to be used for the installation. The Quality Control Plan must fully comply with the specifications and address all anticipated field conditions, including periods of inclement weather.

The APJ shall not be installed when bituminous concrete overlay or joint cutout is wet. The APJ shall only be installed when the bridge superstructure surface temperature is within the limits specified in Table D and when the ambient air temperature is within the range of 45°F to 95°F.

The bridge superstructure surface temperature range is determined using the thermal movement range provided on the contract plans for the proposed APJ deck installation location and the selected APJ product.

**Table D**

<b>Installation Restrictions</b>	
<b>Designed Deck Joint Thermal Movement Range<sup>2</sup></b>	<b>Bridge Superstructure Surface Temperature<sup>1</sup></b>
0" to 1"	45° F to 95° F
1-1/8"	45° F to 90° F
1-1/4"	45° F to 80° F
1-3/8"	45° F to 70° F
1-1/2"	45° F to 65° F

- 1. The superstructure surface temperature shall be determined from the average of three or more surface temperature readings taken at different locations on the interior girder surfaces by the Contractor as directed by the Engineer. Temperature measurements of the superstructure shall be taken by the contractor with a calibrated hand held digital infrared laser-sighted thermometer on the surfaces of an interior steel girder, or interior concrete girder protected from direct sunlight. The infrared thermometer to be supplied by the Contractor for this purpose shall meet certification requirements of EN61326-1, EN61010-1, and EN60825-1 maintained by the European Committee for Electrotechnical Standardization (CENELEC). The thermometer shall have a minimum distance-to-spot ratio of 50:1 and shall have adjustable emissivity control. The thermometer shall have a minimum accuracy value of  $\pm 1\%$  of reading or  $\pm 2^\circ\text{F}$ , whichever is greater. The thermometer shall be used in strict accordance with the manufacturer's written directions. An additional infrared thermometer satisfying the same standards to be used in this application shall also be provided to the Engineer for quality assurance purposes.*
- 2. Linear interpolation may be used to determine an allowable surface temperature range for thermal movement ranges in between values shown in the table, as approved by the Engineer.*

Prior to installing the APJ, the Contractor shall determine the exact location of the deck joint beneath the bituminous concrete overly.

The APJ shall be installed symmetrically about the deck joint opening to the dimensions shown on the plans or as directed by the Engineer; not to exceed 24 inches measured perpendicular to the deck joint. The proposed saw cut lines shall be marked on the bituminous concrete overlay by the Contractor and approved by the Engineer, prior to saw-cutting. The saw-cuts delineating the edges of the APJ shall extend full depth of the bituminous concrete overlay.

The existing bituminous concrete overlay, waterproofing membrane and/or existing expansion joint material, within the saw cut limits shall be removed and disposed of by the Contractor to create the joint cutout.

Concrete surfaces that will support the bridging plates shall be smooth and form a plane along and across the deck joint. Rough or damaged concrete surfaces shall be repaired with a leveling compound meeting the requirements of this specification. Deteriorated concrete areas within the joint limits shall be repaired as directed by the Engineer: such repairs, when deemed necessary by the Engineer, shall be compensated for under the applicable concrete deck repair items in the Contract. The existing and repaired concrete surfaces shall provide continuous uniform support for the bridging plate and prevent the plate from rocking and deflecting.

Prior to the installation of the backer rod, all horizontal and vertical surfaces of the joint cutout shall be abrasive blast cleaned using an oil-free, compressed air supply. The entire cutout shall then be cleared of all loose blast media, dust, debris and moisture using an oil-free, hot air lance capable of producing an air stream at 3,000°F with a velocity of 3,000 feet per second.

A single backer rod, with a diameter at least 25% greater than the existing joint opening at the time of installation, shall be installed at an inch below the bridging plate in the existing deck joint opening between the concrete edges.

Asphaltic binder shall be heated to a temperature within the manufacturer's recommended application temperature range which shall be provided in the Quality Control Plan. During application, the temperature of the binder shall be maintained within this range. In no case shall the temperature of the binder go below 350° F nor exceed the manufacturer's recommended maximum heating temperature.

Asphaltic binder shall then be poured into the joint opening until it completely fills the gap above the backer rod. A thin layer of binder shall next be applied to the all horizontal and vertical surfaces of the joint cutout.

Bridging plates shall be abrasive blast-cleaned on-site prior to installation and then placed over the deck joint opening in the joint cutout. The plates shall be centered over the joint opening and secured with locating pins along its centerline. The plates shall be placed end to end, without overlap, such that the gap between plates does not exceed ¼". The plates shall extend to the gutter line and be cut to match the joint's skew angle, where concrete support exists on both sides of the joint. Within APJ installation limits, where concrete support does not exist at both sides of the joint opening (such as where a bridge deck end abuts a bituminous concrete roadway shoulder), bridging plates shall not be installed. Installed bridging plates shall not rock or deflect in any way.

After installation of bridging plates, a thin layer of asphaltic binder shall be applied to all exposed surfaces of the plates.

The remainder of the joint cutout shall then be filled with a mixture of hot asphaltic binder and aggregate prepared in accordance with the submitted Quality Control Plan and the following requirements:

- The aggregate shall be heated in a vented, rotating drum mixer by the use of a hot-compressed air lance to a temperature of between 370° F. to 380° F. This drum mixer shall be dedicated solely for the heating and, if necessary, supplemental cleaning of the aggregate. Venting of the gas and loose dust particles shall be accomplished through ¼” drilled holes spaced no more than 3” on center in any direction along the entire outside surface of the drum
- Once the aggregate has been heated, it shall then be transferred to a secondary drum mixer where it shall be fully coated with asphaltic binder. A minimum of two gallons of binder per 100lbs of stone is required.
- The temperature of the aggregate and binder shall be monitored by the contractor with a calibrated digital infrared thermometer.
- The coated aggregate shall be loosely placed in the joint cutout in lifts not to exceed 2 inches.
- Each lift shall be leveled, compacted and then flooded with hot asphaltic binder to the level of the aggregate to fill all voids in the coated aggregate layer. The surface of each lift shall be flooded until only the tips of the aggregate protrude out of the surface.
- The final lift shall be placed such that no stones shall project above the level of the adjacent overlay surface following compaction of the coated aggregate.
- Following installation of the final lift, sufficient time and material shall be provided to allow all voids in the mixture to fill. This step may be repeated as needed.
- The joint shall then be top-dressed by heating the entire area with a hot-compressed air lance and applying binder. The final joint surface must be smooth with no protruding stones and be absent of voids.
- Once top-dressed, the joint shall have an anti-tack material spread evenly over the entire surface to prevent tracking.

The Contractor shall be responsible for removing all binder material that leaks through the joint and is deposited on any bridge component, including underside of decks, headers, beams, diaphragms, bearings, abutments and piers.

Traffic shall not be permitted over the joint until it has cooled to 130° F when measured with a digital infrared thermometer. Use of water to cool the completed joint is permitted.

#### Sidewalk, parapet, and/or curb joint openings

Before placement of any sealing materials in parapets, curbs, or sidewalks, the joints shall be thoroughly cleaned of all scale, loose concrete, dirt, dust, or other foreign matter by abrasive blast cleaning. Residual dust and moisture shall then be removed by blasting with oil free compressed

air using a hot air lance. Projections of concrete into the joint space shall also be removed. The backer rod shall be installed in the joint as shown on the plans. The joint shall be clean and dry before the joint sealant is applied. Under no circumstances is the binder material to be used as a substitute for the joint sealant.

Whenever abrasive blast cleaning is performed under this specification, the Contractor shall take adequate measures to ensure that the abrasive blast cleaning will not cause damage to adjacent traffic or other facilities.

The joint sealant shall be prepared and placed in accordance with the manufacturer's instructions and with the equipment prescribed by the manufacturer. Extreme care shall be taken to ensure that the sealant is placed in accordance with the manufacturer's recommended thickness requirements.

The joint sealant shall be tooled, if required, in accordance with the manufacturer's instructions.

Primer, if required, shall be supplied by the sealant manufacturer and applied in accordance with the manufacturer's instructions.

When the sealing operations are completed, the joints shall be effectively sealed against infiltration of water. Any sealant which does not effectively seal against water shall be removed and replaced at the Contractor's expense.

Any installed joint that exhibits evidence of failure, as determined by the Engineer, such as debonding, cracking, rutting, or shoving of the APJ mixture shall be removed and replaced full-width and full-depth to a length determined by the Engineer at no additional cost to the State.

**Method of Measurement:** This work will be measured for payment by the number of cubic feet of "Asphaltic Plug Expansion Joint System" installed and accepted within approved horizontal limits. No additional measurement will be made for furnishing and installing backer rod and joint sealant in the parapets, concrete medians, curbs and/or sidewalks.

**Basis of Payment:** This work will be paid for at the contract unit price per cubic foot for "Asphaltic Plug Expansion Joint System," complete in place, which price shall include the saw-cutting, removal and disposal of bituminous concrete, membrane waterproofing, existing joint components and sealing elements, the furnishing and placement of the leveling compound, cleaning of the joint surfaces, furnishing and installing bridging plates, the furnishing and installing of the asphaltic plug joint mixture, the cost of furnishing and installing joint sealant in the parapets, concrete medians, curbs and sidewalks, and all other materials, equipment including, but not limited to, portable lighting, tools, and labor incidental thereto. No additional payment shall be made for the 12" wide bridging plates that are required for deck joint openings with widths in excess of 3".

If directed by the Engineer, additional deck repairs will be addressed and paid for under the applicable concrete deck repair items in the Contract.

**ITEM #0728014A - CRUSHED STONE**

**Description:** This work shall consist of furnishing, placing and spreading gravel in plant beds as shown on the contract plans.

**Materials:** 3/4 Inch Crushed Stone: Crushed stone shall be a quarry product obtained from offsite sources for use as detailed on the drawings. Crushed stone shall consist of durable, angular crushed rock essentially free of fines, silt, clay, loam or other deleterious materials and shall conform to the following gradation requirements for the nominal size indicated.

<b>SQUARE MESH SIEVES</b>	<b>PERCENT FINER BY WEIGHT</b>
Pass 1-1/2"	100
Pass 1 Inch	90 - 100
Pass 3/4 Inch	20 - 55
Pass 1/2 Inch	0 - 10

Material shall match existing adjacent materials and shall be approved by the engineer.

**Method of Construction:** Stone shall be hand placed and spread to a depth of 4 in and raked to an even surface over entire bed area as directed.

**Method of Measurement:** This work shall be measured for payment by the number of cubic yards of material furnished.

**Basis of Payment:** This work will be paid for at the contract unit price per cubic yard of "Crushed Stone." The price shall include furnishing, placing and spreading the materials. All other miscellaneous tools, materials, and equipment needed to complete the work shall also be included in the cost of the work.

Pay Item  
0728014A, Crushed Stone

Pay Unit  
C.Y.

**ITEM #0905009A – RESET LANDSCAPE WALL**

**Description:** The contractor shall remove the blocks from the existing landscape wall and reset them once work is complete at the location and to the dimensions shown on the plans or as directed by the Engineer.

**Materials:** The blocks used shall be the existing material from the wall being removed. If this is insufficient or inadequate, the contractor shall supply an approved equal as determined by the Engineer at no additional cost.

**Method of Construction:** The contractor shall carefully remove the existing landscape wall as shown on the plans or as directed by the Engineer. The new wall shall be set in the same location as shown on the plans or as directed by the Engineer. The workmanship and manner shall duplicate those of the original installation.

Any damage caused by the contractor to the existing stone wall that is not incorporated into the new work shall be repaired by the contractor at his own expense to the satisfaction of the Engineer.

**Method of Measurement:** This work will be measured as the number of square feet of landscaping wall reset in accordance with the plans and the directions of the Engineer.

**Basis of Payment:** The unit price shall include the cost of furnishing all labor, materials, and equipment necessary to complete the work.

Pay Item  
Reset Landscape Wall

Pay Unit  
S.F.



**0921009A-MONOLITHIC CONCRETE SIDEWALK AND CURB**

This work shall conform to Section 9.21 “Concrete Sidewalks” of the ConnDOT Standard Specifications, Form 817, supplemented and amended as follows:

**9.21.01—Description:** Delete entire paragraph and replace it with the following:

This item shall consist of monolithic concrete sidewalk and curb constructed on a gravel or reclaimed miscellaneous aggregate base course in the locations and to the dimensions and details shown on the plans or as ordered and in accordance with these specifications.

**9.21.02—Materials:** Add the following:

Reinforcement shall conform to the requirements of Article M.06.01. Class “F” 28-day Minimum Compressive Strength shall be 4,400 psi.

**9.24.04—Method of Measurement:** Add the following:

4. Cost for reinforcement will not be measured for payment, but the cost shall be included in the Monolithic Concrete Sidewalk and Curb.

**9.21.05—Basis of Payment:** Delete entire paragraph and replace it with the following:

This work also includes the cost of removing, salvaging and relaying a part of the roof drain located within the existing bituminous sidewalk for the property located at the northwest corner of the intersection of Rubber Avenue and Hoadley Street.

This work will be paid for at the contract unit price per square foot for "Monolithic Concrete Sidewalk and Curb," complete in place, which price shall include all excavation as specified above, reinforcement, backfill, disposal of surplus material, gravel or reclaimed miscellaneous aggregate base, equipment, tools, materials and labor incidental thereto.

**Pay Item**

**Pay Unit**

Monolithic Concrete Sidewalk and Curb

S.F.

## **ITEM #0922003A - DECORATIVE BITUMINOUS CONCRETE**

### PART 1 GENERAL

#### 1.01 RELATED DOCUMENTS

- A. Drawings and General Provisions of Contract, including General and Supplementary Conditions and other Division 1 Specifications Sections, apply to this Section.

The following are minimum requirements and shall govern except that all Federal, Local and/or State Codes and Ordinances shall govern when their requirements are in excess hereof.

The State of Connecticut Department of Transportation Standard Specifications for Roads, Bridges and Incidental Construction form 817 dated 2016 (CTDOT Form 817).

#### 1.02 DESCRIPTION

- A. Decorative bituminous concrete shall consist of an imprint product consisting of a hot applied polymer modified synthetic asphalt compound incorporating graded sand and granite aggregates, reinforced with two types of fibers.
- B. Decorative bituminous concrete is applied over pavement substrates to create functional and decorative crosswalks, and intersections, as shown on the Contract Drawings.
- C. All decorative bituminous concrete materials shall be produced under a quality system in accordance with ISO 9000 series, and designed to provide durability, load carrying capacity and architectural compatibility with the environment. All raw materials shall be carefully graded for consistency and quality to obtain the highest standards.
- D. Decorative bituminous concrete shall be installed flush and level with the existing surface.
- E. Only Accredited decorative bituminous concrete Installers authorized by the manufacturers of the decorative bituminous concrete product may perform this work.

#### 1.03 DEFINITIONS

- A. "HMA pavement" is Hot Mix Asphalt pavement.

- B. “PCC pavement” is Portland Cement Concrete pavement.
- C. “Owner” means the Owner and refers to the representative person of the Town of Stratford who has decision making authority for the Work.
- D. “Accredited decorative bituminous concrete Installer” refers to a contractor authorized by the decorative bituminous concrete manufacturer to install the decorative bituminous concrete product.

1.04 SUBMITTALS

- A. The Accredited decorative bituminous concrete Installer shall provide written proof of their Accreditation.
- B. The Accredited decorative bituminous concrete Installer shall gain confirmation of correct stamping pattern(s) and colors from the Owner prior to starting the Work.
- C. The construction of mock-ups shall be a minimum of a 6’x6’ section for each color and stamp pattern specified.

PART 2 PRODUCTS

2.01 DECORATIVE BITUMINOUS CONCRETE MATERIAL

Decorative bituminous concrete material is a surfacing material comprising a synthetic bitumen mixed with 25% to 50% filler and 30% to 40% aggregate, wherein said synthetic bitumen comprises from about 5% to about 20% binder resin, from about 1% to about 5% polymer, from about 1% to about 5% plasticizer, from about 0% to 5% pigment, from about 0% to 2% reinforcing fiber and from about 0% to 1% rheology modifier.

2.02 SAND

The sand is to be US mesh # 35 silica sand applied as a surface treatment on the decorative bituminous concrete material.

Particle Size Distribution:

Aperture size (microns)	US mesh size	Wt. % retained
1000	#18	0.1
710	#25	3.0
500	#35	27.5
355	#45	47.5
250	#60	19.3
180	#80	2.1

125	#125	0.4
90	#170	0.1
63	#230	Trace
-63		Trace

The sand is to be completely dry.

### 2.03 DECORATIVE BITUMINOUS CONCRETE GRADE SELECTION

The Accredited decorative bituminous concrete Installer will select the proper grade of decorative bituminous concrete material best suited for the project.

### 2.04 PATTERNS & COLORS

#### A. Crosswalks:

1. Pattern "Offset Brick" in the color "Terracotta".

#### B. Border Accent for Crosswalks & Intersection Square:

1. Pattern "12"x12" Squares" in the color "White".

### 2.05 SHELF LIFE AND STORAGE

The shelf life of decorative bituminous concrete is one year providing it is protected from the weather, specifically UV degradation and rain. The materials are to be stored in their original packaging and kept dry under cover.

### 2.06 MATERIAL USAGE

Thickness	Kilos per m <sup>2</sup>	Lbs per ft <sup>2</sup>	m <sup>2</sup> per tonne*	ft <sup>2</sup> per tonne*
0.6 in. (15mm)	37.0	7.58	27	290
0.8 in. (20 mm)	47.6	9.75	21	226
1.0 in (25 mm)	58.8	12.04	17	183

\*tonne = 1,000 kg or 2,200 lbs.

Allow approx. +5% waste

## PART 3 EXECUTION

### 3.01 PRE-CONDITIONS

Decorative bituminous concrete shall be installed over new pavement. The pavement must be firm, stable and in excellent condition; it must be free from defects such as cracks, settlement, visible seams, ruts, bird baths and spalling.

- A. Cracking, settlement and other deficiencies of the substrate will likely reflect through the decorative bituminous concrete. Good and proper construction procedures for the installation of the substrate must be followed in order to mitigate cracking of decorative bituminous concrete.
- B. Surfaces with a high degree of porosity should be avoided due to the problems associated with entrapped water.
- C. Surfaces that may be subject to uncontrolled movement in either a horizontal or vertical direction shall be avoided as there may be a risk of reflective cracking through to the decorative bituminous concrete surface. Notify the engineer if these conditions are present before installing decorative bituminous concrete.
- D. A skid resistance of 40 or less will require the pavement surface to be roughened and a primer applied.

### 3.02 PREPARATION OF THE SUBSTRATE.

All pavement substrates must be of high quality and stable for the installation of decorative bituminous concrete.

This Section is to be used as a guide to ensure a high quality pavement substrate is provided and ready for the installation of decorative bituminous concrete. It does not supersede other specifications pertaining to this Work, nor does it replace recommendations made by the engineer of record for this Work.

- A. The base and sub-grade over which new pavement is installed must be firm and stable.
- B. The pavement mix must be designed for the intended use.
- C. The pavement must be installed in accordance with proper placement practices and these specifications.
- D. PCC pavement must be permitted to cure properly before installing decorative bituminous concrete.
- E. PCC pavement is to be treated with Thermobond primer prior to installation of decorative bituminous concrete. The primer must dry before installing decorative bituminous concrete. Thermobond primer is available to Accredited Installers and Manufactures.
- F. For new HMA pavement substrates, it is recommended that the surface be opened to traffic for a period of time prior to installation of decorative bituminous concrete in order to provide further compaction of the asphalt and to allow the asphalt oils to “cure” out. Bituminous residue must be

removed from new HMA pavement surface prior to installation of decorative bituminous concrete.

- G. Older HMA pavements that show signs of oxidization will require the application of Thermobond primer prior to the installation of decorative bituminous concrete.

### 3.03 FULL MILLING OF PAVEMENT FOR FLUSH INSTALLATIONS

The installation area boundaries shall be saw-cut prior to excavating the pavement materials for a clean straight, full depth edge. All pavement materials shall be milled and all excess material removed. The depth of the milled area shall allow the depth of the decorative bituminous concrete material to be maintained within a range of 0.6" to 0.8" depth across the entire installation.

The existing pavement must be free of cracks. The milling process will not necessarily remove existing pavement cracks.

### 3.04 SURFACE PREPARATION

The pavement surface shall be dry and clean: free of all dirt, debris, salts, concrete admixtures and any chemical residues.

- A. Bituminous residue must be removed from new HMA pavement surface prior to installation of decorative bituminous concrete.
- B. Removal of contaminants may be done by brooming, compressed air, pressure washing or if necessary light-grit blasting. Wire brush may be used to remove loose or powdery materials.
- C. Surfaces with a high degree of porosity require a primer before decorative bituminous concrete is installed. Thermobond Primer available from decorative bituminous concrete manufacturer is the recommended primer.

### 3.05 INSTALLATION OF DECORATIVE BITUMINOUS CONCRETE

Decorative bituminous concrete is to be installed only by an Accredited Installer.

- A. Application Temperature Conditions
- B. Typical material application temperature: 374°F – 410°F.
- C. Maximum safe heating temperature: 437°F.
- D. Air/Road temperature: Minimum 40°F and rising.
- E. Application thickness: decorative bituminous concrete is to be applied at a thickness of 0.6" to 0.8".
- F. For substrates that have properly installed control joints, to the extent where possible it is recommended to lay the decorative bituminous concrete pattern in such a way that the natural joints of the pattern

coincide with the construction joints in the substrate. To help mitigate reflective cracking through to the decorative bituminous concrete, a construction joint coinciding with the substrate control joint must be installed in the decorative bituminous concrete.

- G. The decorative bituminous concrete material shall be prepared for installation utilizing a heating kettle specifically designed for hot applied polymer modified synthetic asphalt surface treatment and capable of mixing components to a homogenous consistency. The Material shall be heated within the temperature range of 374°F – 410°F prior to installation. To preserve the integrity of the material, do not overheat the decorative bituminous concrete material.
- H. The decorative bituminous concrete material shall be uniformly distributed onto the pavement surface by means of pre-heated finishing irons.
- I. The heated and mixed material is hand applied over the prepared surface at an average depth of between 0.6” and 0.8”. Grade control devices may be used by the Accredited decorative bituminous concrete Installer to ensure the proper thickness is obtained.
- J. Interface with adjacent surfaces shall be flush, providing smooth transition from surface to surface. Precautions to protect the immediate perimeter around the installation are to be taken.
- K. Applying the sand cover: Immediately apply the dried silica sand at an approximate rate of 0.2 lb/SF. The placement of this material does not require any compaction.
- L. Decorative bituminous concrete the pattern design: The Accredited Installer will stamp the pattern into the semi-molten material immediately after the silica sand application using an approved mold. The mold is pressed into the material to a depth of between 0.2” and 0.4” depending on the thickness of the material.
- M. After initial set, remove excess aggregate by hand or suction sweeping prior to opening to traffic.
- N. Heat all cold edges to ensure good adhesion between successive applications of material.

### 3.06 OPEN TO TRAFFIC

The Work can be open to traffic when the decorative bituminous concrete material has cooled and hardened. This is typically 1 hour, but depends on the actual ambient conditions. More time may be required in hot weather. The Accredited decorative bituminous concrete Installer can advise when the Work is ready for traffic.

## PART 4 – MEASUREMENT AND PAYMENT

### 4.01 METHOD OF MEASUREMENT

The item decorative bituminous concrete shall be measure as follows:

The measured area is the square foot area of installed, measured and accepted in place. No deduction will be made for the area(s) occupied by manholes, inlets, drainage structures, bollards or by any public utility appurtenances within the area.

### 4.02 BASIS OF PAYMENT

Payment for decorative bituminous concrete shall be paid for at the contract unit price per square foot of decorative bituminous concrete complete and accepted in place, which price shall include all materials, equipment, tools and labor incidental thereto, and all saw cutting, milling, and disposal of surplus material.

There will be no direct payment for surface preparation; but the cost of this work shall be considered as included in the general cost of the work.

Pay Item	Pay Unit
Decorative bituminous concrete (crosswalk)	SF.



## **ITEM #0969062A - CONSTRUCTION FIELD OFFICE, MEDIUM**

**Description:** Under the item included in the bid document, adequate weatherproof office quarters with related furnishings, materials, equipment and other services, shall be provided by the Contractor for the duration of the work, and if necessary, for a close-out period determined by the Engineer. The office, furnishings, materials, equipment, and services are for the exclusive use of CTDOT forces and others who may be engaged to augment CTDOT forces with relation to the Contract. The office quarters shall be located convenient to the work site and installed in accordance with Article 1.08.02. This office shall be separated from any office occupied by the Contractor. Ownership and liability of the office quarters shall remain with the Contractor.

**Furnishings/Materials/Supplies/Equipment:** All furnishings, materials, equipment and supplies shall be in like new condition for the purpose intended and require approval of the Engineer.

**Office Requirements:** The Contractor shall furnish the office quarters and equipment as described below:

Description \ Office Size	Small	Med.	Large	Extra Large
Minimum Sq. Ft. of floor space with a minimum ceiling height of 7 ft.	400	400	1000	2000
Minimum number of exterior entrances.	2	2	2	2
Minimum number of parking spaces.	7	7	10	15

**Office Layout:** The office shall have a minimum square footage as indicated in the table above, and shall be partitioned as shown on the building floor plan as provided by the Engineer.

**Tie-downs and Skirting:** Modular offices shall be tied-down and fully skirted to ground level.

**Lavatory Facilities:** For field offices sizes Small and Medium the Contractor shall furnish a toilet facility at a location convenient to the field office for use by Department personnel and such assistants as they may engage; and for field offices sizes Large and Extra Large the Contractor shall furnish two (2) separate lavatories with toilet (men and women), in separately enclosed rooms that are properly ventilated and comply with applicable sanitary codes. Each lavatory shall have hot and cold running water and flush-type toilets. For all facilities the Contractor shall supply lavatory and sanitary supplies as required.

**Windows and Entrances:** The windows shall be of a type that will open and close conveniently, shall be sufficient in number and size to provide adequate light and ventilation, and shall be fitted with locking devices, blinds and screens. The entrances shall be secure, screened, and fitted with a lock for which four keys shall be furnished. All keys to the construction field office shall be furnished to the Department and will be kept in their possession while State personnel are using the office. Any access to the entrance ways shall meet applicable building codes, with appropriate handrails. Stairways shall be ADA/ABA compliant and have non-skid tread surfaces. An ADA/ABA compliant ramp with non-skid surface shall be provided with the Extra-Large field office.

Lighting: The Contractor shall equip the office interior with electric lighting that provides a minimum illumination level of 100 foot-candles at desk level height, and electric outlets for each desk and drafting table. The Contractor shall also provide exterior lighting that provides a minimum illumination level of 2 foot-candles throughout the parking area and for a minimum distance of 10 ft. on each side of the field office.

Parking Facility: The Contractor shall provide a parking area, adjacent to the field office, of sufficient size to accommodate the number of vehicles indicated in the table above. If a paved parking area is not readily available, the Contractor shall construct a parking area and driveway consisting of a minimum of 6 inches of processed aggregate base graded to drain. The base material will be extended to the office entrance.

Field Office Security: Physical Barrier Devices - This shall consist of physical means to prevent entry, such as: 1) All windows shall be barred or security screens installed; 2) All field office doors shall be equipped with dead bolt locks and regular day operated door locks; and 3) Other devices as directed by the Engineer to suit existing conditions.

Electric Service: The field office shall be equipped with an electric service panel to serve the electrical requirements of the field office, including: lighting, general outlets, computer outlets, calculators etc., and meet the following minimum specifications:

- A. 120/240 volt, 1 phase, 3 wire
- B. Ampacity necessary to serve all equipment. Service shall be a minimum 100 amp dedicated to the construction field office.
- C. The electrical panel shall include a main circuit breaker and branch circuit breakers of the size and quantity required.
- D. Additional 120 volt, single phase, 20 amp, isolated ground dedicated power circuit with dual NEMA 5-20 receptacles will be installed at each computer workstation location.
- E. Additional 120 volt, single phase, 20 amp, isolated ground dedicated power circuit with dual NEMA 5-20 receptacles will be installed, for use by the Telephone Company.
- F. Additional 120-volt circuits and duplex outlets as required meeting National Electric Code requirements.
- G. One exterior (outside) wall mounted GFI receptacle, duplex, isolated ground, 120 volt, straight blade.
- H. After work is complete and prior to energizing, the State's CTDOT electrical inspector, must be contacted at 860-594-2240. (Do Not Call Local Town Officials)
- I. Prior to field office removal, the CTDOT Office of Information Systems (CTDOT OIS) must be notified to deactivate the communications equipment.

Heating, Ventilation and Air Conditioning (HVAC): The field office shall be equipped with sufficient heating, air conditioning and ventilation equipment to maintain a temperature range of 68°-80° Fahrenheit within the field office.

Telephone Service: The Contractor shall provide telephone service with unlimited nation-wide calling plan. For a Small, Medium and Large field office this shall consist of the installation of two (2) telephone lines: one (1) line for phone/voice service and one (1) line dedicated for the facsimile machine. For an Extra-Large field office this shall consist of four (4) telephone lines: three (3) lines for phone/voice service and one (1) line dedicated for facsimile machine. The Contractor shall pay all charges.

Data Communications Facility Wiring: Contractor shall install a Category 6 568B patch panel in a central wiring location and Cat 6 cable from the patch panel to each PC station, Smart Board location, Multifunction Laser Printer/Copier/Scanner/Fax, terminating in a (Category 6 568B) wall or surface mount data jack. The central wiring location shall also house either the data circuit with appropriate power requirements or a category 5 cable run to the location of the installed data circuit. The central wiring location will be determined by the CTDOT OIS staff in coordination with the designated field office personnel as soon as the facility is in place.

For Small, Medium and Large field offices the Contractor shall run a CAT 6 LAN cable a minimum length of 25 feet for each computer to LAN switch area leaving an additional 10 feet of cable length on each side with terminated RJ45 connectors. For an Extra-Large field office the Contractor shall run CAT 6 LAN cables from workstations, install patch panel in data circuit demark area and terminate runs with RJ45 jacks at each computer location. Terminate runs to patch panel in LAN switch area. Each run / jack shall be clearly labeled with an identifying Jack Number.

The Contractor shall supply cables to connect the Wi-Fi printer to the Contractor supplied internet router and to workstations as needed. These cables shall be separate from the LAN cables and data Jacks detailed above for the Department network.

The installation of a data communication circuit between the field office and the CTDOT OIS in Newington will be coordinated between the CTDOT District staff, CTDOT OIS staff and the local utility company once the Contractor supplies the field office phone numbers and anticipated installation date. The Contractor shall provide the field office telephone number(s) to the CTDOT Project Engineer within 10 calendar days after the signing of the Contract as required by Article 1.08.02. This is required to facilitate data line and computer installations.

Additional Equipment, Facilities and Services: The Contractor shall provide at the field Office at least the following to the satisfaction of the Engineer:

Furnishing Description	Office Size			
	Small	Med.	Large	Extra Large
	Quantity			
Office desk (2.5 ft. x 5 ft.) with drawers, locks, and matching desk chair that have pneumatic seat height adjustment and dual wheel casters on the base.	1	3	5	8
Standard secretarial type desk and matching desk chair that has pneumatic seat height adjustment and dual wheel casters on the base.	-	-	-	1
Personal computer tables (4 ft. x 2.5 ft.).	2	3	5	8
Drafting type tables (3 ft. x 6 ft.) and supported by wall brackets and legs; and matching drafters stool that have pneumatic seat height adjustment, seat back and dual wheel casters on the base.	1	1	1	2
Conference table, 3 ft. x 12 ft.	-	-	-	1
Table – 3 ft. x 6 ft.	-	-	-	1
Office Chairs.	2	4	8	20
Mail slot bin – legal size.	-	-	1	1
Non-fire resistant cabinet.	-	-	2	4
Fire resistant cabinet (legal size/4 drawer), locking.	1	1	2	3
Storage racks to hold 3 ft. x 5 ft. display charts.	-	-	1	2
Vertical plan racks for 2 sets of 2 ft. x 3 ft. plans for each rack.	1	1	2	2
Double door supply cabinet with 4 shelves and a lock – 6 ft. x 4 ft.	-	-	1	2
Case of cardboard banker boxes (Min 10 boxes/case)	1	1	2	3
Open bookcase – 3 shelves – 3 ft. long.	-	-	2	2
White Dry-Erase Board, 36" x 48"min. with markers and eraser.	1	1	1	1
Interior partitions – 6 ft. x 6 ft., soundproof type, portable and freestanding.	-	-	6	6
Coat rack with 20 coat capacity.	-	-	-	1
Wastebaskets - 30 gal., including plastic waste bags.	1	1	1	2
Wastebaskets - 5 gal., including plastic waste bags.	1	3	6	10
Electric wall clock.	-	-	-	2
Telephone.	1	1	1	-
Full size stapler 20 (sheet capacity, with staples)	1	2	5	8
Desktop tape dispensers (with Tape)	1	2	5	8
8 Outlet Power Strip with Surge Protection	3	4	6	9
Rain Gauge	1	1	1	1

Business telephone system for three lines with ten handsets, intercom capability, and one speaker phone for conference table.	-	-	-	1
Mini refrigerator - 3.2 c.f. min.	1	1	1	1
Hot and cold water dispensing unit. Disposable cups and bottled water shall be supplied by the Contractor for the duration of the project.	1	1	1	1
Microwave, 1.2 c.f. , 1000W min.	1	1	1	1
Fire extinguishers - provide and install type and *number to meet applicable State and local codes for size of office indicated, including a fire extinguisher suitable for use on a computer terminal fire.	*	*	*	*
Electric pencil sharpeners.	1	2	2	2
Electronic office type printing calculators capable of addition, subtraction, multiplication and division with memory and a supply of printing paper.	1	1	2	4
Small Multi-Function Laser Printer/Copier/Scanner/Fax combination unit, network capable, as specified below under <u>Computer Hardware and Software</u> .	1	1		
Large Multi-Function Laser Printer/Copier/Scanner/Fax combination unit, network capable, as specified below under <u>Computer Hardware and Software</u> .			1	1
Field Office Wi-Fi Connection as specified below under <u>Computer Hardware and Software</u>	1	1	1	1
Wi-Fi Printer as specified below under <u>Computer Hardware and Software</u> .	1	1	1	1
Digital Camera as specified below under <u>Computer Hardware and Software</u> .	1	1	3	3
Video Projector as specified below under <u>Computer Hardware and Software</u> .	-	-	-	1
Smart Board as specified below under <u>Computer Hardware and Software</u> .	-	-	-	1
Infrared Thermometer, including annual third party certified calibration, case, and cleaning wipes.	1	1	1	2
Concrete Curing Box as specified below under Concrete Testing Equipment.	1	1	1	1
Concrete Air Meter and accessories as specified below under Concrete Testing Equipment as specified below. Contractor shall provide third party calibration on a quarterly basis.	1	1	1	1
Concrete Slump Cone and accessories as specified below under Concrete Testing Equipment.	1	1	1	1
First Aid Kit	1	1	1	1

Flip Phones as specified under <u>Computer Hardware and Software</u> .	-	-	-	-
Smart Phones as specified under <u>Computer Hardware and Software</u> .	-	-	-	-

The furnishings and equipment required herein shall remain the property of the Contractor. Any supplies required to maintain or operate the above listed equipment or furnishings shall be provided by the Contractor for the duration of the project.

Computer Hardware and Software: Field Office Wi-Fi Connection, Wi-Fi Printer, Digital Camera(s), Flip Phones, Smart Phones, Multifunction Laser Printer/Copier/Scanner/Fax, Video Projectors, and Smart Board(s) as well as associated hardware and software, must meet the requirements of this specification as well as the latest minimum specifications posted, as of the project advertising date, at Departments web site <http://www.ct.gov/dot/cwp/view.asp?a=1410&q=563904>

Within 10 calendar days after the signing of the Contract but before ordering/purchasing the Wi-Fi Printer (separate from the Multifunction Laser Printer/Copier/Scanner/Fax), Field Office Wi-Fi, Digital Camera(s), Flip Phones, Smart Phones, Multifunction Laser Printer/Copier/Scanner/Fax, Video Projector(s) and Smart Board(s) as well as associated hardware, the Contractor must submit a copy of their proposed order(s) with catalog cuts and specifications to the Administering CTDOT District for review and approval. The Wi-Fi Printer, Wi-Fi Router, Flip Phones, Smart Phones, digital cameras, Projector(s) and Smart Board(s) will be reviewed by CTDOT District personnel. The Multifunction Laser Printer/Copier/Scanner/Fax will be reviewed by the CTDOT OIS. The Contractor shall not purchase the hardware, software, or services until the Administering CTDOT District informs them that the proposed equipment, software, and services are approved. The Contractor will be solely responsible for the costs of any hardware, software, or services purchased without approval.

The Contractor and/or their internet service provider shall be responsible for the installation and setup of the field office Wi-Fi, Wi-Fi printer, and the configuration of the wireless router as directed by the Department. Installation will be coordinated with CTDOT District and Project personnel.

After the approval of the hardware and software, the Contractor shall contact the designated representatives of the CTDOT administering District, a minimum of 2 working days in advance of the proposed delivery or installation of the Field Office Wi-Fi Connection, Wi-Fi Printer, Digital Camera(s), Flip Phones, Smart Phones, Multifunction Laser Printer/Copier/Scanner/Fax, Video Projectors and Smart Board(s), as well as associated hardware, software, supplies, and support documentation.

The Contractor shall provide all supplies, paper, maintenance, service and repairs (including labor and parts) for the Wi-Fi printers, copiers, field office Wi-Fi, fax machines and other equipment and facilities required by this specification for the duration of the Contract. All repairs must be performed with-in 48 hours. If the repairs require more than a 48 hours then an equal or better replacement must be provided.

Once the Contract has been completed, the hardware and software will remain the property of the Contractor.

First Aid Kit: The Contractor shall supply a first aid kit adequate for the number of personnel expected based on the size of the field office specified and shall keep the first aid kit stocked for the duration that the field office is in service.

Rain Gauge: The Contractor shall supply install and maintain a rain gauge for the duration of the project, meeting these minimum requirements. The rain gauge shall be installed on the top of a post such that the opening of the rain gauge is above the top of the post an adequate distance to avoid splashing of rain water from the top of the post into the rain gauge. The Location of the rain gauge and post shall be approved by the Engineer. The rain gauge shall be made of a durable material and have graduations of 0.1 inches or less with a minimum total column height of 5 inches. If the rain gauge is damaged the Contractor shall replace it prior to the next forecasted storm event at no additional cost.

Concrete Testing Equipment: If the Contract includes items that require compressive strength cylinders for concrete, in accordance with the Schedule of Minimum Testing Requirements for Sampling Materials for Test, the Contractor shall provide the following equipment.

- A) Concrete Cylinder Curing Box – meeting the requirements of Section 6.12 of the Standard Specifications.
- B) Air Meter – The air meter provided shall be in good working order and meet the requirements of AASHTO T 152.
- C) Slump Cone Mold – Slump cone, base plate, and tamping rod shall be provided in like-new condition and meet the requirements of AASHTO T119, Standard Test Method for Slump of Hydraulic-Cement Concrete.

All testing equipment will remain the property of the Contractor at the completion of the project.

Insurance Policy: The Contractor shall provide a separate insurance policy, with no deductible, in the minimum amount of five thousand dollars (\$5,000) in order to insure all State-owned data equipment and supplies used in the office against all losses. The Contractor shall be named insured on that policy, and the Department shall be an additional named insured on the policy. These losses shall include, but not be limited to: theft, fire, and physical damage. The Department will be responsible for all maintenance costs of Department owned computer hardware. In the event of loss, the Contractor shall provide replacement equipment in accordance with current Department equipment specifications, within seven days of notice of the loss. If the Contractor is unable to provide the required replacement equipment within seven days, the Department may provide replacement equipment and deduct the cost of the equipment from monies due or which may become due the Contractor under the Contract or under any other contract. The Contractor's financial liability under this paragraph shall be limited to the amount of the insurance coverage required by this paragraph. If the cost of equipment replacement required by this paragraph should exceed the required amount of the insurance coverage, the Department will reimburse the Contractor for replacement costs exceeding the amount of the required coverage.

**Maintenance:** During the occupancy by the Department, the Contractor shall maintain all facilities and furnishings provided under the above requirements, and shall maintain and keep the office quarters clean through the use of weekly professional cleaning to include, but not limited to, washing & waxing floors, cleaning restrooms, removal of trash, etc. Exterior areas shall be mowed and clean of debris. A trash receptacle (dumpster) with weekly pickup (trash removal) shall be provided. Snow removal, sanding and salting of all parking, walkway, and entrance ways areas shall be accomplished during a storm if on a workday during work hours, immediately after a storm and prior to the start of a workday. If snow removal, salting and sanding are not completed by the specified time, the State will provide the service and all costs incurred will be deducted from the next payment estimate.

**Method of Measurement:** The furnishing and maintenance of the construction field office will be measured for payment by the number of calendar months that the office is in place and in operation, rounded up to the nearest month.

There will not be any price adjustment due to any change in the minimum computer hardware and software requirements.

**Basis of Payment:** The furnishing and maintenance of the Construction Field Office will be paid for at the Contract unit price per month for “Construction Field Office, (Type),” which price shall include all material, equipment, labor, service contracts, licenses, software, repair or replacement of hardware and software, related supplies, utility services, parking area, external illumination, trash removal, snow and ice removal, and work incidental thereto, as well as any other costs to provide requirements of this specified this specification.

<u>Pay Item</u>	<u>Pay Unit</u>
Construction Field Office, (Medium)	Month



**ITEM NO. 0971001A – MAINTENANCE AND PROTECTION OF TRAFFIC**

**Article 9.71.01 – Description is supplemented by the following:**

The Contractor shall maintain and protect traffic as described by the following and as limited in the Special Provision "Prosecution and Progress":

**Rubber Avenue, Hoadley Street, and Melbourne Street**

The Contractor shall maintain and protect a minimum of one lane of traffic in each direction, each lane on a paved travel path not less than 11 feet in width.

Where turn lanes exist, the Contractor shall provide an additional 10 feet of paved travel path to be used for turning vehicles only. This additional 10 feet of travel path shall be a minimum length of 75 feet. It shall be implemented so that sufficient storage, taper length, and turning radius are provided.

The Contractor shall apply the final course of bituminous concrete as a final operation for the full width and length of the roadway.

The Contractor shall schedule operations so that roadway resurfacing shall be full-width across the roadway section at the end of the workday, all transverse pavement height differentials shall be tapered enough to the satisfaction of the Engineer, so as to negate any “bump” to traffic.

**All Other Roadways**

The Contractor shall maintain and protect existing traffic operations on all other roadways.

Excepted therefrom will be those periods, during the allowable periods, when the Contractor is actually working, at which time the Contractor shall maintain and protect at least an alternating one-way traffic operation on a paved travel path not less than 11 feet in width. The length of the alternating one-way traffic operation shall not exceed 300 feet in length. There shall be no more than one alternating one-way traffic operation within the site limits without prior approval of the Engineer.

The Contractor shall apply the final course of bituminous concrete as a final operation for the full width and length of the roadway.

The Contractor shall schedule operations so that roadway resurfacing shall be full-width across the roadway section at the end of the workday, all transverse pavement height differentials shall be tapered enough to the satisfaction of the Engineer, so as to negate any “bump” to traffic.

### **Commercial and Residential Driveways**

The Contractor shall maintain access to and egress from all residential driveways throughout the project limits. If a temporary closure of a residential driveway is necessary, the Contractor shall coordinate with the owner to determine the time period of the closure.

### **Pedestrian Access**

The Contractor shall maintain pedestrian access along Rubber Avenue, Hoadley Street, and Melbourne Street at all times. The Contractor shall detour pedestrians to appropriate sidewalks and crosswalks as needed and as directed by the Engineer.

If any portion of sidewalk or pedestrian walkway is located within the work zone, the Contractor shall provide a temporary sidewalk or pedestrian detour with adequate signing for a safe pedestrian passage.

The Contractor shall prepare a pedestrian access plan to accommodate pedestrians.

### **Article 9.71.03 - Construction Method is supplemented as follows:**

#### **General**

Unpaved travel paths will only be permitted for areas requiring full depth and full width reconstruction, in which case, the Contractor will be allowed to maintain traffic on processed aggregate for a duration not to exceed 10 calendar days. The unpaved section shall be the full width of the road and perpendicular to the travel lanes. Opposing traffic lane dividers shall be used as a centerline.

The Contractor is required to delineate any raised structures within the travel lanes, so that the structures are visible day and night, unless there are specific contract plans and provisions to temporarily lower these structures prior to the completion of work.

The Contractor shall schedule operations so that pavement removal and roadway resurfacing shall be completed full width across a roadway (bridge) section by the end of a workday (work night), or as directed by the Engineer.

When the installation of all intermediate courses of bituminous concrete pavement is completed for the entire roadway, the Contractor shall install the final course of bituminous concrete pavement.

When the Contractor is excavating adjacent to the roadway, the Contractor shall provide a 3-foot shoulder between the work area and travel lanes, with traffic drums spaced every 50 feet. At the end of the workday, if the vertical drop-off exceeds 3 inches, the Contractor shall provide a temporary traversable slope of 4:1 or flatter that is acceptable to the Engineer.

The Contractor, during the course of active construction work on overhead signs and structures, shall close the lanes directly below the work area for the entire length of time overhead work is being undertaken. At no time shall an overhead sign be left partially removed or installed.

If applicable, when an existing sign is removed, it shall be either relocated or replaced by a new sign during the same working day.

The Contractor shall not store any material on-site which would present a safety hazard to motorists or pedestrians (e.g. fixed object or obstruct sight lines).

The field installation of a signing pattern shall constitute interference with existing traffic operations and shall not be allowed, except during the allowable periods.

Construction vehicles entering travel lanes at speeds less than the posted speed are interfering with traffic, and shall not be allowed without a lane closure. The lane closure shall be of sufficient length to allow vehicles to enter or exit the work area at posted speeds, in order to merge with existing traffic.

### **Existing Signing**

The Contractor shall maintain all existing overhead and side-mounted signs throughout the project limits during the duration of the project. The Contractor shall temporarily relocate signs and sign supports as many times as deemed necessary, and install temporary sign supports if necessary and as directed by the Engineer.

### **Requirements for Winter**

The Contractor shall schedule a meeting with representatives from the Department including the offices of Maintenance and Traffic, and the Town/City to determine what interim traffic control measures the Contractor shall accomplish for the winter to provide safety to the motorists and permit adequate snow removal procedures. This meeting shall be held prior to October 31 of each year and will include, but not be limited to, discussion of the status and schedule of the following items: lane and shoulder widths, pavement restoration, traffic signal work, pavement markings, and signing.

### **Signing Patterns**

The Contractor shall erect and maintain all signing patterns in accordance with the traffic control plans contained herein. Proper distances between advance warning signs and proper taper lengths are mandatory.

**Pavement Markings -Non-Limited Access Multilane Roadways  
Secondary and Local Roadways**

During construction, the Contractor shall maintain all pavement markings on paved surfaces on all roadways throughout the limits of the project.

**Interim Pavement Markings**

The Contractor shall install painted pavement markings, which shall include centerlines, shoulder edge lines, lane lines (broken lines), lane-use arrows, and stop bars, on each intermediate course of bituminous concrete pavement and on any milled surface by the end of the work day/night. If the next course of bituminous concrete pavement will be placed within seven days, shoulder edge lines are not required. The painted pavement markings will be paid under the appropriate items.

If the Contractor will install another course of bituminous concrete pavement within 24 hours, the Contractor may install Temporary Plastic Pavement Marking Tape in place of the painted pavement markings by the end of the work day/night. These temporary pavement markings shall include centerlines, lane lines (broken lines) and stop bars; shoulder edge lines are not required. Centerlines shall consist of two 4 inch wide yellow markings, 2 feet in length, side by side, 4 to 6 inches apart, at 40-foot intervals. No passing zones should be posted with signs in those areas where the final centerlines have not been established on two-way roadways. Stop bars may consist of two 6 inch wide white markings or three 4 inch wide white markings placed side by side. The Contractor shall remove and dispose of the Temporary Plastic Pavement Marking Tape when another course of bituminous concrete pavement is installed. The cost of furnishing, installing and removing the Temporary Plastic Pavement Marking Tape shall be at the Contractor's expense.

If an intermediate course of bituminous concrete pavement will be exposed throughout the winter, then Epoxy Resin Pavement Markings should be installed unless directed otherwise by the Engineer.

**Final Pavement Markings**

The Contractor should install painted pavement markings on the final course of bituminous concrete pavement by the end of the work day/night. If the painted pavement markings are not installed by the end of the work day/night, then Temporary Plastic Pavement Marking Tape shall be installed as described above and the painted pavement markings shall be installed by the end of the work day/night on Friday of that week.

If Temporary Plastic Pavement Marking Tape is installed, the Contractor shall remove and dispose of these markings when the painted pavement markings are installed. The cost of

furnishing, installing and removing the Temporary Plastic Pavement Marking Tape shall be at the Contractor's expense.

The Contractor shall install permanent Epoxy Resin Pavement Markings in accordance with Section 12.10 entitled "Epoxy Resin Pavement Markings, Symbols, and Legends" after such time as determined by the Engineer.

## **TRAFFIC CONTROL DURING CONSTRUCTION OPERATIONS**

The following guidelines shall assist field personnel in determining when and what type of traffic control patterns to use for various situations. These guidelines shall provide for the safe and efficient movement of traffic through work zones and enhance the safety of work forces in the work area.

### **TRAFFIC CONTROL PATTERNS**

Traffic control patterns shall be used when a work operation requires that all or part of any vehicle or work area protrudes onto any part of a travel lane or shoulder. For each situation, the installation of traffic control devices shall be based on the following:

- Speed and volume of traffic
- Duration of operation
- Exposure to hazards

Traffic control patterns shall be uniform, neat and orderly so as to command respect from the motorist.

In the case of a horizontal or vertical sight restriction in advance of the work area, the traffic control pattern shall be extended to provide adequate sight distance for approaching traffic.

If a lane reduction taper is required to shift traffic, the entire length of the taper should be installed on a tangent section of roadway so that the entire taper area can be seen by the motorist.

Any existing signs that are in conflict with the traffic control patterns shall be removed, covered, or turned so that they are not readable by oncoming traffic.

When installing a traffic control pattern, a Buffer Area should be provided and this area shall be free of equipment, workers, materials and parked vehicles.

Typical traffic control plans 19 through 25 may be used for moving operations such as line striping, pot hole patching, mowing, or sweeping when it is necessary for equipment to occupy a travel lane.

Traffic control patterns will not be required when vehicles are on an emergency patrol type activity or when a short duration stop is made and the equipment can be contained within the shoulder. Flashing lights and appropriate trafficperson shall be used when required.

Although each situation must be dealt with individually, conformity with the typical traffic control plans contained herein is required. In a situation not adequately covered by the typical traffic control plans, the Contractor must contact the Engineer for assistance prior to setting up a traffic control pattern.

### **PLACEMENT OF SIGNS**

Signs must be placed in such a position to allow motorists the opportunity to reduce their speed prior to the work area. Signs shall be installed on the same side of the roadway as the work area. On multi-lane divided highways, advance warning signs shall be installed on both sides of the highway. On directional roadways (on-ramps, off-ramps, one-way roads), where the sight distance to signs is restricted, these signs should be installed on both sides of the roadway.

### **ALLOWABLE ADJUSTMENT OF SIGNS AND DEVICES SHOWN ON THE TRAFFIC CONTROL PLANS**

The traffic control plans contained herein show the location and spacing of signs and devices under ideal conditions. Signs and devices should be installed as shown on these plans whenever possible.

The proper application of the traffic control plans and installation of traffic control devices depends on actual field conditions.

Adjustments to the traffic control plans shall be made only at the direction of the Engineer to improve the visibility of the signs and devices and to better control traffic operations. Adjustments to the traffic control plans shall be based on safety of work forces and motorists, abutting property requirements, driveways, side roads, and the vertical and horizontal curvature of the roadway.

The Engineer may require that the traffic control pattern be located significantly in advance of the work area to provide better sight line to the signing and safer traffic operations through the work zone.

Table I indicates the minimum taper length required for a lane closure based on the posted speed limit of the roadway. These taper lengths shall only be used when the recommended taper lengths shown on the traffic control plans cannot be achieved.

**TABLE I – MINIMUM TAPER LENGTHS**

POSTED SPEED LIMIT MILES PER HOUR	MINIMUM TAPER LENGTH IN FEET FOR A SINGLE LANE CLOSURE
30 OR LESS	180
35	250
40	320
45	540
50	600
55	660
65	780

**SECTION 1. WORK ZONE SAFETY MEETINGS**

- 1.a) Prior to the commencement of work, a work zone safety meeting will be conducted with representatives of DOT Construction, Connecticut State Police (Local Barracks), Municipal Police, the Contractor (Project Superintendent) and the Traffic Control Subcontractor (if different than the prime Contractor) to review the traffic operations, lines of responsibility, and operating guidelines which will be used on the project. Other work zone safety meetings during the course of the project should be scheduled as needed.
  
- 1.b) A Work Zone Safety Meeting Agenda shall be developed and used at the meeting to outline the anticipated traffic control issues during the construction of this project. Any issues that can't be resolved at these meetings will be brought to the attention of the District Engineer and the Office of Construction. The agenda should include:
  - Review Project scope of work and time
  - Review Section 1.08, Prosecution and Progress
  - Review Section 9.70, Trafficpersons
  - Review Section 9.71, Maintenance and Protection of Traffic
  - Review Contractor's schedule and method of operations.
  - Review areas of special concern: ramps, turning roadways, medians, lane drops, etc.
  - Open discussion of work zone questions and issues
  - Discussion of review and approval process for changes in contract requirements as they relate to work zone areas

**SECTION 2. GENERAL**

- 2.a) **If the required minimum number of signs and equipment (i.e. one High Mounted Internally Illuminated Flashing Arrow for each lane closed, two TMAs, Changeable**

**Message Sign, etc.) are not available; the traffic control pattern shall not be installed.**

- 2.b) The Contractor shall have back-up equipment (TMAs, High Mounted Internally Illuminated Flashing Arrow, Changeable Message Sign, construction signs, cones/drums, etc.) available at all times in case of mechanical failures, etc. The only exception to this is in the case of sudden equipment breakdowns in which the pattern may be installed but the Contractor must provide replacement equipment within 24 hours.
- 2.c) Failure of the Contractor to have the required minimum number of signs, personnel and equipment, which results in the pattern not being installed, shall not be a reason for a time extension or claim for loss time.
- 2.d) In cases of legitimate differences of opinion between the Contractor and the Inspection staff, the Inspection staff shall err on the side of safety. The matter shall be brought to the District Office for resolution immediately or, in the case of work after regular business hours, on the next business day.

### **SECTION 3. INSTALLING AND REMOVING TRAFFIC CONTROL PATTERNS**

- 3.a) Lane Closures shall be installed beginning with the advance warning signs and proceeding forward toward the work area.
- 3.b) Lane Closures shall be removed in the reverse order, beginning at the work area, or end of the traffic control pattern, and proceeding back toward the advance warning signs.
- 3.c) Stopping traffic may be allowed:
  - As per the contract for such activities as blasting, steel erection, etc.
  - During paving, milling operations, etc. where, in the middle of the operation, it is necessary to flip the pattern to complete the operation on the other half of the roadway and traffic should not travel across the longitudinal joint or difference in roadway elevation.
  - To move slow moving equipment across live traffic lanes into the work area.
- 3.d) Under certain situations when the safety of the traveling public and/or that of the workers may be compromised due to conditions such as traffic volume, speed, roadside obstructions, or sight line deficiencies, as determined by the Engineer and/or State Police, traffic may be briefly impeded while installing and/or removing the advance warning signs and the first ten traffic cones/drums only. Appropriate measures shall be taken to safely slow traffic. If required, traffic slowing techniques may be used and shall include the use of Truck Mounted Impact Attenuators (TMAs) as appropriate, for a minimum of one mile in advance of the pattern starting point. Once the advance warning signs and



the first ten traffic cones/drums are installed/removed, the TMAs and sign crew shall continue to install/remove the pattern as described in Section 5 and traffic shall be allowed to resume their normal travel.

- 3.e) The Contractor must adhere to using the proper signs, placing the signs correctly, and ensuring the proper spacing of signs.
- 3.f) Additional devices are required on entrance ramps, exit ramps, and intersecting roads to warn and/or move traffic into the proper travel path prior to merging/exiting with/from the main line traffic. This shall be completed before installing the mainline pattern past the ramp or intersecting roadway.
- 3.g) Prior to installing a pattern, any conflicting existing signs shall be covered with an opaque material. Once the pattern is removed, the existing signs shall be uncovered.
- 3.h) On limited access roadways, workers are prohibited from crossing the travel lanes to install and remove signs or other devices on the opposite side of the roadway. Any signs or devices on the opposite side of the roadway shall be installed and removed separately.

#### **SECTION 4. USE OF HIGH MOUNTED INTERNALLY ILLUMINATED FLASHING ARROW**

- 4.a) On limited access roadways, one Flashing Arrow shall be used for each lane that is closed. The Flashing Arrow shall be installed concurrently with the installation of the traffic control pattern and its placement shall be as shown on the traffic control plan. For multiple lane closures, one Flashing Arrow is required for each lane closed. If conditions warrant, additional Flashing Arrows should be employed (i.e.: curves, major ramps, etc.).
- 4.b) On non-limited access roadways, the use of a Flashing Arrow for lane closures is optional. The roadway geometry, sight line distance, and traffic volume should be considered in the decision to use the Flashing Arrow.
- 4.c) The Flashing Arrow shall not be used on two lane, two-way roadways for temporary alternating one-way traffic operations.
- 4.d) The Flashing Arrow board display shall be in the “arrow” mode for lane closure tapers and in the “caution” mode (four corners) for shoulder work, blocking the shoulder, or roadside work near the shoulder. The Flashing Arrow shall be in the “caution” mode when it is positioned in the closed lane.
- 4.e) The Flashing Arrow shall not be used on a multi-lane roadway to laterally shift all lanes of traffic, because unnecessary lane changing may result.

**SECTION 5. USE OF TRUCK MOUNTED IMPACT ATTENUATOR VEHICLES (TMAs)**

- 5.a) For lane closures on limited access roadways, a minimum of two TMAs shall be used to install and remove traffic control patterns. If two TMAs are not available, the pattern shall not be installed.
- 5.b) On non-limited access roadways, the use of TMAs to install and remove patterns closing a lane(s) is optional. The roadway geometry, sight line distance, and traffic volume should be considered in the decision to utilize the TMAs.
- 5.c) Generally, to establish the advance and transition signing, one TMA shall be placed on the shoulder and the second TMA shall be approximately 1,000 feet ahead blocking the lane. The flashing arrow board mounted on the TMA should be in the “flashing arrow” mode when taking the lane. The sign truck and workers should be immediately ahead of the second TMA. In no case shall the TMA be used as the sign truck or a work truck. Once the transition is in place, the TMAs shall travel in the closed lane until all Changeable Message Signs, signs, Flashing Arrows, and cones/drums are installed. The flashing arrow board mounted on the TMA should be in the “caution” mode when traveling in the closed lane.
- 5.d) A TMA shall be placed prior to the first work area in the pattern. If there are multiple work areas within the same pattern, then additional TMAs shall be positioned at each additional work area as needed. The flashing arrow board mounted on the TMA should be in the “caution” mode when in the closed lane.
- 5.e) TMAs shall be positioned a sufficient distance prior to the workers or equipment being protected to allow for appropriate vehicle roll-ahead in the event that the TMA is hit, but not so far that an errant vehicle could travel around the TMA and into the work area. For additional placement and use details, refer to the specification entitled “Type ‘D’ Portable Impact Attenuation System”. Some operations, such as paving and concrete repairs, do not allow for placement of the TMA(s) within the specified distances. In these situations, the TMA(s) should be placed at the beginning of the work area and shall be advanced as the paving or concrete operations proceed.
- 5.f) TMAs should be paid in accordance with how the unit is utilized. When it is used as a TMA and is in the proper location as specified, and then it should be paid at the specified hourly rate for “Type ‘D’ Portable Impact Attenuation System”. When the TMA is used as a Flashing Arrow, it should be paid at the daily rate for “High Mounted Internally Illuminated Flashing Arrow”. If a TMA is used to install and remove a pattern and then is used as a Flashing Arrow, the unit should be paid as a “Type ‘D’ Portable Impact Attenuation System” for the hours used to install and remove the pattern, typically 2 hours (1 hour to install and 1 hour to remove), and is also paid for the day as a “High Mounted Internally Illuminated Flashing Arrow”.

## **SECTION 6. USE OF TRAFFIC DRUMS AND TRAFFIC CONES**

- 6.a) Traffic drums shall be used for taper channelization on limited-access roadways, ramps, and turning roadways and to delineate raised catch basins and other hazards.
- 6.b) Traffic drums shall be used in place of traffic cones in traffic control patterns that are in effect for more than a 36-hour duration.
- 6.c) Traffic Cones less than 42 inches in height shall not be used on limited-access roadways or on non-limited access roadways with a posted speed limit of 45 mph and above.
- 6.d) Typical spacing of traffic drums and/or cones shown on the Traffic Control Plans in the Contract are maximum spacings and may be reduced to meet actual field conditions as required.

## **SECTION 7. USE OF (REMOTE CONTROLLED) CHANGEABLE MESSAGE SIGNS (CMS)**

- 7.a) For lane closures on limited access roadways, one CMS shall be used in advance of the traffic control pattern. Prior to installing the pattern, the CMS shall be installed and in operation, displaying the appropriate lane closure information (i.e.: Left Lane Closed - Merge Right). The CMS shall be positioned  $\frac{1}{2}$  - 1 mile ahead of the lane closure taper. If the nearest Exit ramp is greater than the specified  $\frac{1}{2}$  - 1 mile distance, than an additional CMS shall be positioned a sufficient distance ahead of the Exit ramp to alert motorists to the work and therefore offer them an opportunity to take the exit.
- 7.b) CMS should not be installed within 1000 feet of an existing CMS.
- 7.c) On non-limited access roadways, the use of CMS for lane closures is optional. The roadway geometry, sight line distance, and traffic volume should be considered in the decision to use the CMS.
- 7.d) The advance CMS is typically placed off the right shoulder, 5 feet from the edge of pavement. In areas where the CMS cannot be placed beyond the edge of pavement, it may be placed on the paved shoulder with a minimum of five (5) traffic drums placed in a taper in front of it to delineate its position. The advance CMS shall be adequately protected if it is used for a continuous duration of 36 hours or more.
- 7.e) When the CMS are no longer required, they should be removed from the clear zone and have the display screen cleared and turned 90° away from the roadway.
- 7.f) The CMS generally should not be used for generic messages (ex: Road Work Ahead, Bump Ahead, Gravel Road, etc.).

- 7.g) The CMS should be used for specific situations that need to command the motorist's attention which cannot be conveyed with standard construction signs (Examples include: Exit 34 Closed Sat/Sun - Use Exit 35, All Lanes Closed - Use Shoulder, Workers on Road - Slow Down).
- 7.h) Messages that need to be displayed for long periods of time, such as during stage construction, should be displayed with construction signs. For special signs, please coordinate with the Office of Construction and the Division of Traffic Engineering for the proper layout/dimensions required.
- 7.i) The messages that are allowed on the CMS are as follows:

<u>Message No.</u>	<u>Frame 1</u>	<u>Frame 2</u>	<u>Message No.</u>	<u>Frame 1</u>	<u>Frame 2</u>
1	LEFT LANE CLOSED	MERGE RIGHT	9	LANES CLOSED AHEAD	REDUCE SPEED
2	2 LEFT LANES CLOSED	MERGE RIGHT	10	LANES CLOSED AHEAD	USE CAUTION
3	LEFT LANE CLOSED	REDUCE SPEED	11	WORKERS ON ROAD	REDUCE SPEED
4	2 LEFT LANES CLOSED	REDUCE SPEED	12	WORKERS ON ROAD	SLOW DOWN
5	RIGHT LANE CLOSED	MERGE LEFT	13	EXIT XX CLOSED	USE EXIT YY
6	2 RIGHT LANES CLOSED	MERGE LEFT	14	EXIT XX CLOSED USE YY	FOLLOW DETOUR
7	RIGHT LANE	REDUCE SPEED	15	2 LANES SHIFT	USE CAUTION

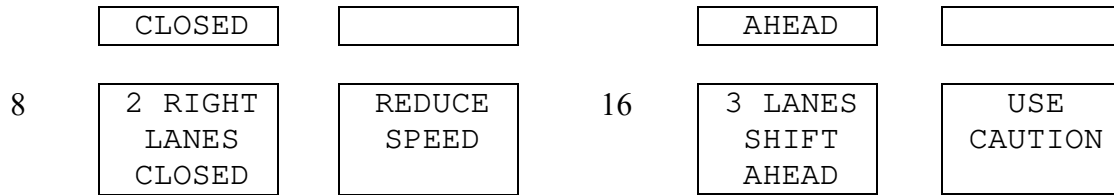

For any other message(s), approval must be received from the Office of Construction prior to their use. No more than two (2) displays shall be used within any message cycle.

**SECTION 8. USE OF STATE POLICE OFFICERS**

- 8.a) State Police may be utilized only on limited access highways and secondary roadways under their primary jurisdiction. One Officer may be used per critical sign pattern. Shoulder closures and right lane closures can generally be implemented without the presence of a State Police Officer. Likewise in areas with moderate traffic and wide, unobstructed medians, left lane closures can be implemented without State Police presence. Under some situations it may be desirable to have State Police presence, when one is available. Examples of this include: nighttime lane closures; left lane closures with minimal width for setting up advance signs and staging; lane and shoulder closures on turning roadways/ramps or mainline where sight distance is minimal; and closures where extensive turning movements or traffic congestion regularly occur, however they are not required.
- 8.b) Once the pattern is in place, the State Police Officer should be positioned in a non-hazardous location in advance of the pattern. If traffic backs up beyond the beginning of the pattern, then the State Police Officer shall be repositioned prior to the backup to give warning to the oncoming motorists. The State Police Officer and TMA should not be in proximity to each other.
- 8.c) Other functions of the State Police Officer(s) may include:
  - Assisting entering/exiting construction vehicles within the work area.
  - Enforcement of speed and other motor vehicle laws within the work area, if specifically requested by the project.
- 8.d) State Police Officers assigned to a work site are to only take direction from the Engineer.

# WORK IN TRAVEL LANE AND SHOULDER TWO LANE HIGHWAY ALTERNATING ONE-WAY TRAFFIC OPERATIONS

SIGN FACE  
108 SQ. FT (MIN.)

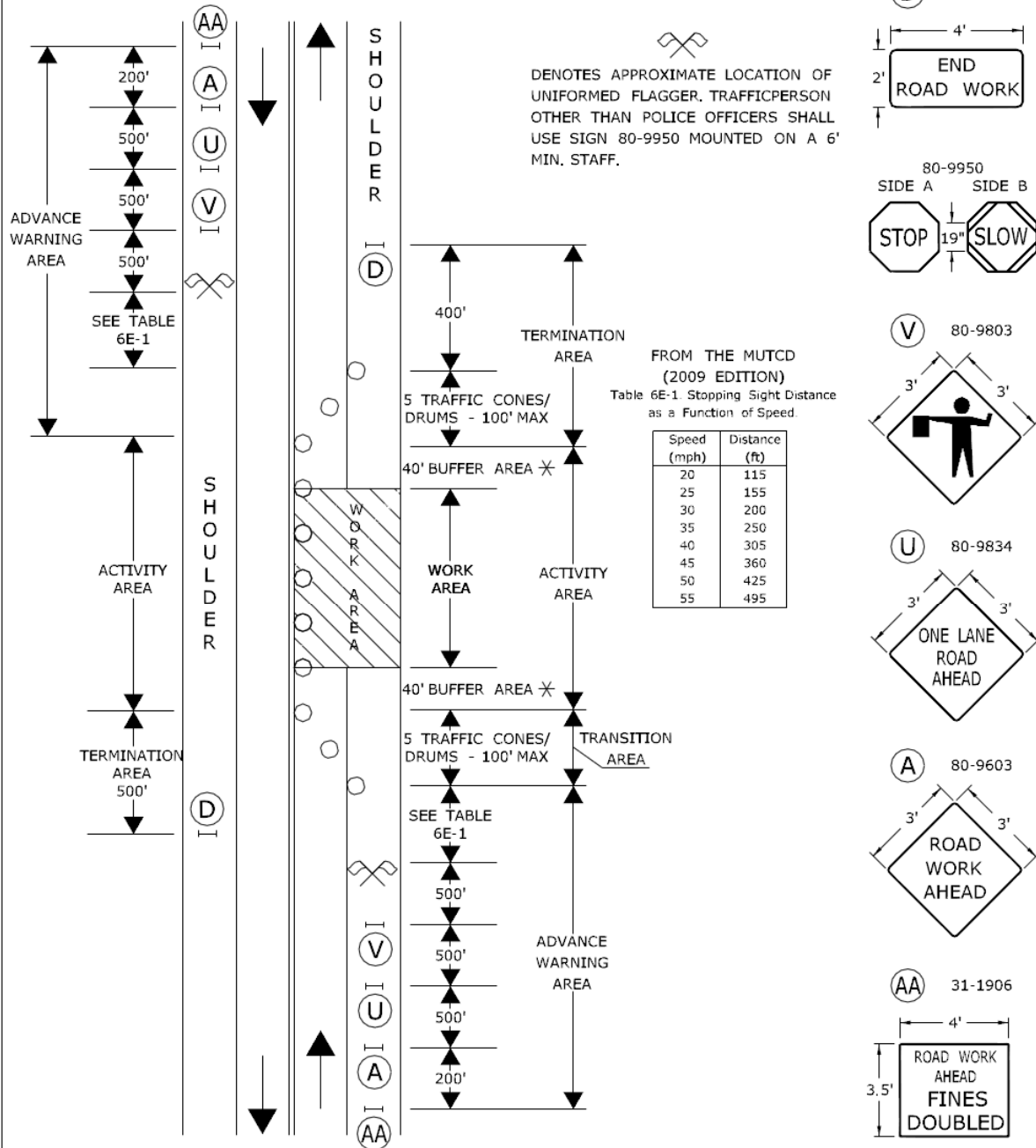

- TRAFFIC CONE OR TRAFFIC DRUM
- ✱ OPTIONAL ✕ TRAFFIC DRUM — PORTABLE SIGN SUPPORT
- ◀ HIGH MOUNTED INTERNALLY ILLUMINATED FLASHING ARROW



SCALE: NONE

CONSTRUCTION TRAFFIC CONTROL PLAN  
**PLAN 13 - SHEET 1 OF 2**  
SEE NOTES 1, 2, 4, 6, 7, 8

CONNECTICUT DEPARTMENT OF TRANSPORTATION  
BUREAU OF ENGINEERING & CONSTRUCTION

APPROVED *Charles S. Harlow* Charles S. Harlow  
2012.06.05 15:55:23-04'00"  
PRINCIPAL ENGINEER

# WORK IN TRAVEL LANE AND SHOULDER TWO LANE HIGHWAY ALTERNATING ONE-WAY TRAFFIC OPERATIONS

SIGN FACE  
108 SQ. FT (MIN.)

## HAND SIGNAL METHODS TO BE USED BY UNIFORMED FLAGGERS

THE FOLLOWING METHODS FROM SECTION 6E.07, FLAGGER PROCEDURES, IN THE "MANUAL ON UNIFORM TRAFFIC CONTROL DEVICES," SHALL BE USED BY UNIFORMED FLAGGERS WHEN DIRECTING TRAFFIC THROUGH A WORK AREA. THE STOP/SLOW SIGN PADDLE (SIGN NO. 80-9950) SHOWN ON THE TRAFFIC STANDARD SHEET TR-1220 01 ENTITLED, "SIGNS FOR CONSTRUCTION AND PERMIT OPERATIONS" SHALL BE USED.

**A. TO STOP TRAFFIC**

TO STOP ROAD USERS, THE FLAGGER SHALL FACE ROAD USERS AND AIM THE STOP PADDLE FACE TOWARD ROAD USERS IN A STATIONARY POSITION WITH THE ARM EXTENDED HORIZONTALLY AWAY FROM THE BODY. THE FREE ARM SHALL BE HELD WITH THE PALM OF THE HAND ABOVE SHOULDER LEVEL TOWARD APPROACHING TRAFFIC.



**B. TO DIRECT TRAFFIC TO PROCEED**

TO DIRECT STOPPED ROAD USERS TO PROCEED, THE FLAGGER SHALL FACE ROAD USERS WITH THE SLOW PADDLE FACE AIMED TOWARD ROAD USERS IN A STATIONARY POSITION WITH THE ARM EXTENDED HORIZONTALLY AWAY FROM THE BODY. THE FLAGGER SHALL MOTION WITH THE FREE HAND FOR ROAD USERS TO PROCEED.



**C. TO ALERT OR SLOW TRAFFIC**

TO ALERT OR SLOW TRAFFIC, THE FLAGGER SHALL FACE ROAD USERS WITH THE SLOW PADDLE FACE AIMED TOWARD ROAD USERS IN A STATIONARY POSITION WITH THE ARM EXTENDED HORIZONTALLY AWAY FROM THE BODY. TO FURTHER ALERT OR SLOW TRAFFIC, THE FLAGGER HOLDING THE SLOW PADDLE FACE TOWARD ROAD USERS MAY MOTION UP AND DOWN WITH THE FREE HAND, PALM DOWN.



- TRAFFIC CONE **OR** TRAFFIC DRUM
- \* OPTIONAL ⊗ TRAFFIC DRUM — PORTABLE SIGN SUPPORT
- ◀ HIGH MOUNTED INTERNALLY ILLUMINATED FLASHING ARROW



SCALE: NONE

CONSTRUCTION TRAFFIC CONTROL PLAN  
**PLAN 13 - SHEET 2 OF 2**  
SEE NOTES 1, 2, 4, 6, 7, 8

CONNECTICUT DEPARTMENT OF TRANSPORTATION  
BUREAU OF ENGINEERING & CONSTRUCTION

APPROVED *Charles S. Harlow*  
PRINCIPAL ENGINEER Charles S. Harlow  
2012.06.05 15:55:45-04'00'

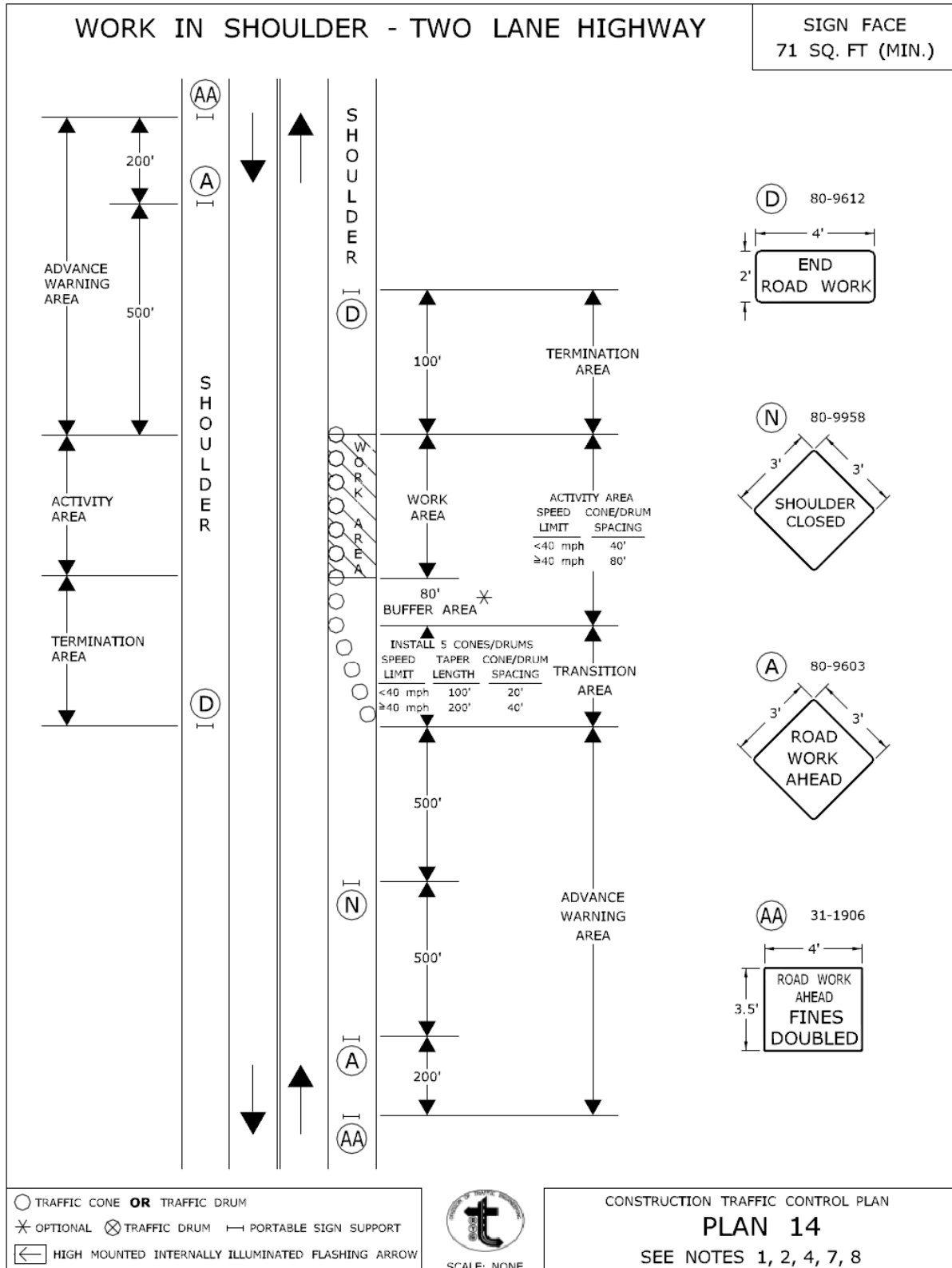

○ TRAFFIC CONE OR TRAFFIC DRUM  
 ✱ OPTIONAL ✕ TRAFFIC DRUM — PORTABLE SIGN SUPPORT  
 ◀ HIGH MOUNTED INTERNALLY ILLUMINATED FLASHING ARROW

CONSTRUCTION TRAFFIC CONTROL PLAN  
**PLAN 14**  
SEE NOTES 1, 2, 4, 7, 8

CONNECTICUT DEPARTMENT OF TRANSPORTATION  
BUREAU OF ENGINEERING & CONSTRUCTION

APPROVED *Charles S. Harlow* Charles S. Harlow  
2012.06.05 15:56:09-04'00"  
PRINCIPAL ENGINEER



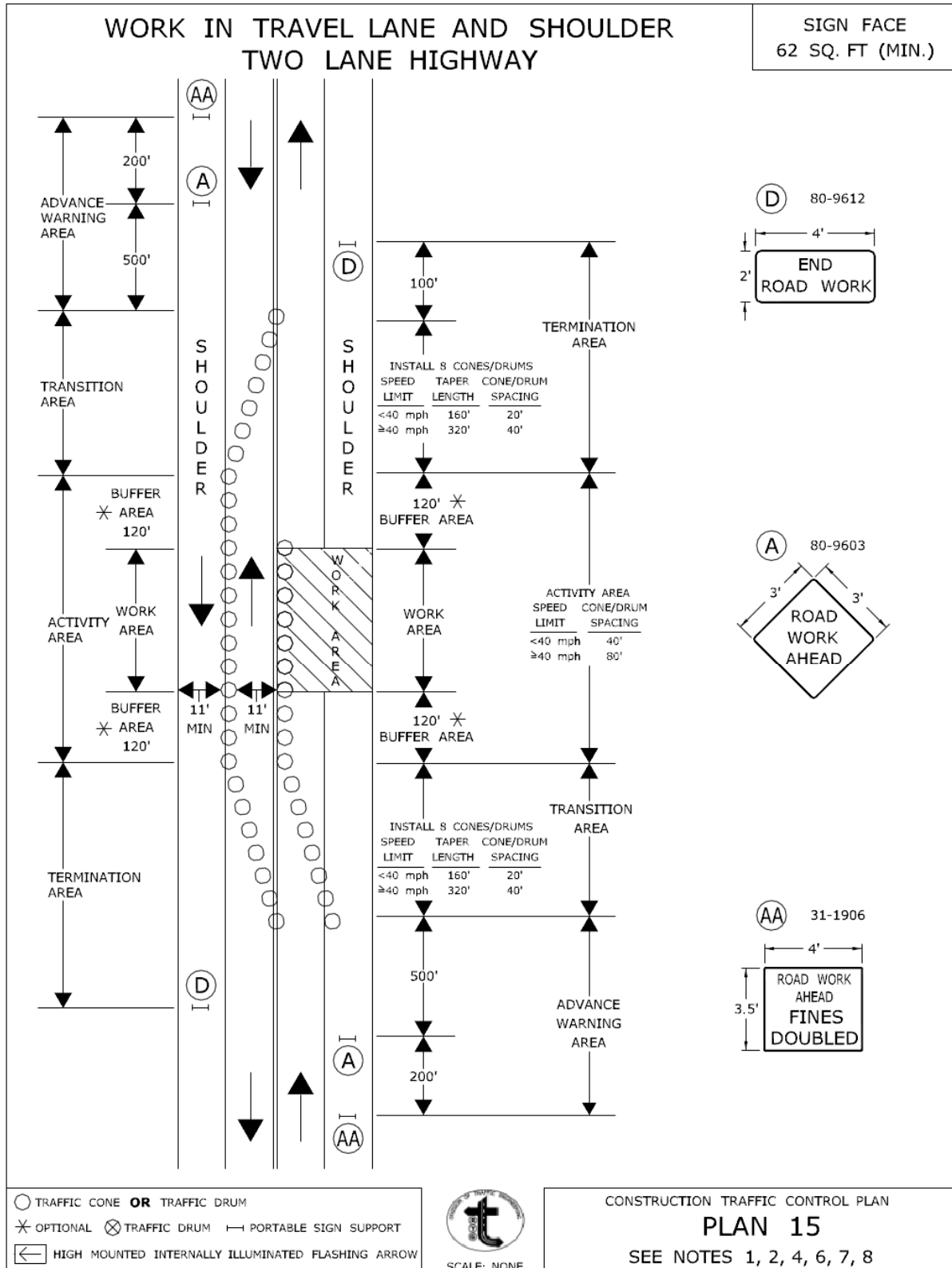

APPROVED *Charles S. Harlow* Charles S. Harlow  
2012.06.05 15:56:29-04'00"  
PRINCIPAL ENGINEER

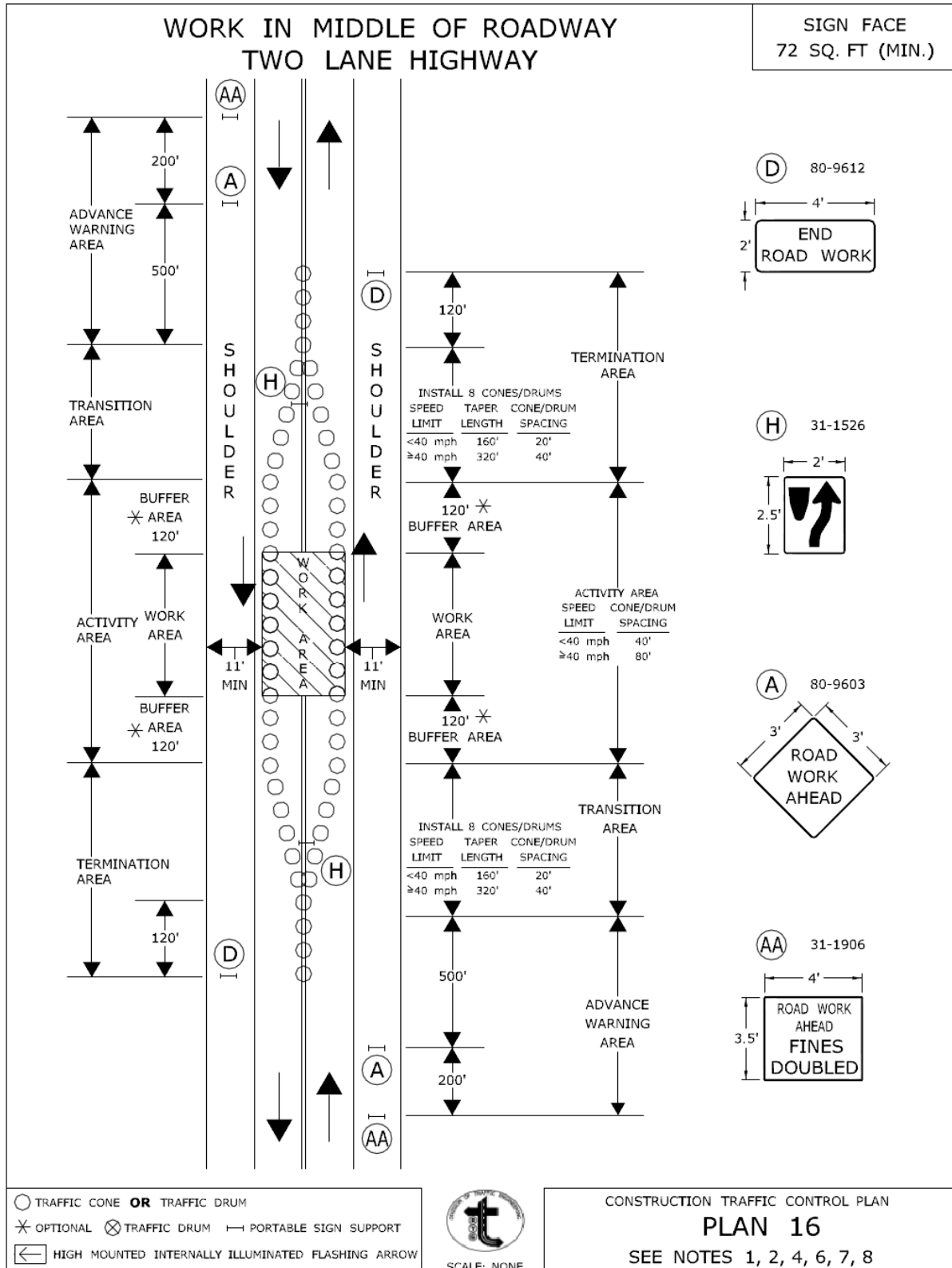

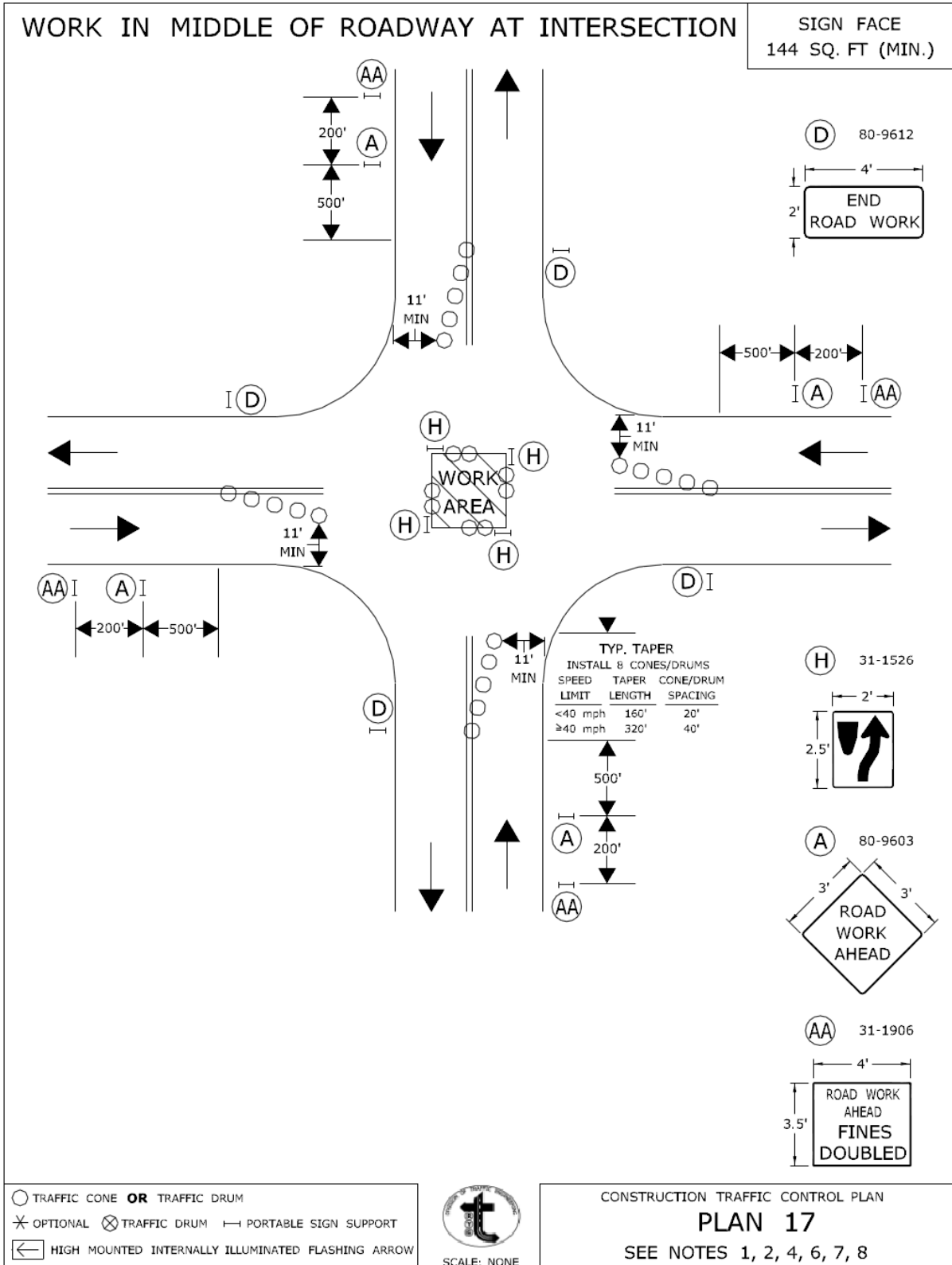

CONNECTICUT DEPARTMENT OF TRANSPORTATION  
 BUREAU OF ENGINEERING & CONSTRUCTION

APPROVED *Charles S. Harlow* Charles S. Harlow  
 2012.06.05 15:57:16-04'00"  
 PRINCIPAL ENGINEER

**Article 9.71.05 – Basis of Payment is supplemented by the following:**

The temporary relocation of signs and supports, and the furnishing, installation and removal of any temporary supports shall be paid for under the item “Maintenance and Protection of Traffic”. Temporary overhead sign supports and foundations shall be paid for under the appropriate item(s).

The cost of furnishing, installing, and removing the material for the 4H:1V traversable slope shall be paid for under the item “Maintenance and Protection of Traffic.”

## **ITEM #1002201A – TRAFFIC CONTROL FOUNDATION – SPAN POLE**

**Description:** Work under this item shall consist of designing and constructing drilled shaft foundations for steel span poles, in accordance with the details shown on the plans, in accordance with these specifications and as ordered by the Engineer.

**Materials:** The reinforcing steel shall be uncoated, ASTM A615, Grade 60 reinforcement conforming to the requirements of Article M.06.01.

The concrete for the drilled shaft shall conform to Article M.03 for Class 'F' Concrete. The 28 day minimum compressive strength of the concrete in the constructed foundation shall be 4,400 psi. The concrete mix design, including admixtures, shall be submitted to the Engineer for approval.

The slurry shall be Contractor designed mineral slurry that meets the range of values listed herein. The slurry mix design, including admixtures, shall be submitted to the Engineer for approval.

Rigid metal conduit, ground rod sleeves and related hardware, and end caps shall be galvanized steel conduit, and shall conform to Article M.15.09.

Ground rods shall be 5/8" in diameter by 10'-0" long copper clad steel. The copper cladding shall be a minimum thickness of 0.128". The ground clamp shall be a square-head bolt type, approved for direct burial.

Bare copper wire shall conform to Article M.15.13.

Topsoil shall conform to Article M.13.01.

Fertilizer shall conform to Article M.13.03.

Seed mixture shall conform to Article M.13.04.

Mulch shall conform to Article M.13.05.

Erosion control matting shall conform to Article M.13.09.

**Construction Methods:** For the purpose of bidding this item, the Contractor shall assume that the subsurface conditions for each drilled shaft foundation location consists of cohesionless, medium dense, granular soil (AASHTO A-1 or A-2) with cobbles present and a high groundwater table which requires the use of wet construction/concreting methods. During excavation and construction of each foundation, should the Contractor encounter subsurface conditions that differ materially from those assumed at the time of bid, the Contractor shall

notify the Engineer. All matters regarding increased cost relating to an agreed upon change in subsurface conditions will be handled per Section 1.04.04 – Differing Site Conditions.

The design of drilled shaft foundations shall conform to the requirements of AASHTO Standard Specifications for Structural Supports for Highway Signs, Luminaries and Traffic Signals – latest edition, including the latest interim specifications, available prior to the advertising date of the contract, amended as follows:

- The foundation shall be designed for the soils and rock properties and parameters based on the subsurface conditions (character of the soil and rock, presence of ground water, etc.) in the location of, adjacent to and below the drilled shaft foundation excavation. The need and extent of all subsurface explorations and investigations shall be determined by the Contractor.
- The specified compressive strength,  $f'_c$ , of the concrete used in the design shall be 4,000 psi.
- The reinforcement shall be uncoated and conform to ASTM A615, Grade 60.
- The foundation shall be designed for the span pole reactions of all group loads and load combinations. The reactions shall include axial, shear, flexural and torsional load effects. No reduction of the reactions or increase in the allowable stresses of the materials is permitted.
- The diameter of the drilled shaft foundation shall be 3'-0", unless otherwise allowed by the Engineer.
- The design of the drilled shaft foundation shall include embedment of the foundation in soil, the embedment of the foundation in rock or the embedment of the foundation partially in soil and partially in rock, as applicable.
- The design of the drilled shaft embedment depth shall account for the slope of the finished grade.
- The minimum embedment for a drilled shaft foundation, constructed entirely in soil, shall be no less than 12'-0" below the finished grade at the low side of a sloping grade. The minimum embedment for a drilled shaft foundation, constructed entirely in rock shall be no less than 8'-0" below the finished grade at the low side of a sloping grade.
- The embedment depth for a drilled shaft foundation, determined by the Brom's design method, shall have a minimum factor of safety of 3.25 applied to the shear and moment load effects. The factor of safety applied to the torsional load effect shall be no less than 1.3.

- The load factor method shall be used for the structural design of the drilled shaft foundation. The load factor applied to all loads, dead, wind and ice, and their effects, axial, shear, flexure and torsion, shall be no less than 1.6. The drilled shaft may be designed in accordance with the load factor method presented in the latest edition of the Building Code Requirements for Reinforced Concrete”, ACI 318.
- The structural design of the drilled shaft shall be based on stress and strain compatibility in the circular drilled shaft cross section. The use of methods equating circular to rectangular drilled shaft cross sections is not permitted.
- The drilled shaft foundation shall be reinforced with longitudinal and transverse reinforcement. The area of longitudinal reinforcement should be no less than the sum of the reinforcement required for flexure and the longitudinal reinforcement required for torsion. The area of transverse reinforcement should be no less than the sum of the reinforcement required for shear and the transverse reinforcement required for torsion.
- The minimum number of longitudinal reinforcing bars shall be 16. The minimum size of longitudinal reinforcing bars shall be #8. The minimum area of longitudinal reinforcing bars shall be no less than 1% of the gross cross-sectional area of the shaft. The minimum clear distance between longitudinal reinforcing bars shall be no less than 5 times the maximum aggregate size or 5”, whichever is greater. The reinforcement shall extend full length of the drilled shaft foundation, including the pedestal. Splicing of the longitudinal reinforcement is not permitted.
- The drilled shaft foundation shall be transversely reinforced with spirals or circular, one piece, enclosed ties. The minimum size of the transverse reinforcement shall be #4. The maximum spacing/pitch of the transverse reinforcement shall be no more than 6”. The minimum spacing/pitch of the transverse reinforcement shall be no more than 4”. The spiral reinforcement shall be terminated at the top and the bottom with 1 ½ turns of the reinforcing and a 135° standard hook. Spirals may be spliced with lap splices or mechanical connectors. For spirals, the minimum lap splice length shall be 1.7 times the tension development length (including modification factors) of the bar or 48 bar diameters, whichever is greater. For spirals, the mechanical connectors shall develop both in tension and compression 125% of the specified yield strength of the bar and conform to the latest edition of the AASHTO LRFD Bridge Design Specifications, including the latest interim specifications. For ties, the minimum lap splice length shall be no less than 1.7 times the tension development length (including modification factors) of the bar. Tie lap splices shall be alternated.

- The design of the foundation shall be coordinated with the traffic structure to avoid conflicts between the embedded support anchorage and the foundation reinforcement.

The Contractor's foundation designer shall obtain a Professional Liability Insurance Policy in accordance with the requirements of Article 1.05.02-2a. A Contractor shall submit a copy of the certificate of insurance to the Engineer in accordance with the requirements of Article 1.05.02-2a.

Prior to excavating for the foundation, the Contractor shall submit working drawings and design computations for each span pole foundation to the Engineer for review in accordance with Article 1.05.02. An individual, independently packaged set of working drawings and computations, with all details and documents necessary for fabrication and construction, including a copy of the certificate of insurance, shall be prepared and submitted for **each** span pole foundation. **A single set of drawings with tabulated data for multiple foundation locations is not permitted.** The alpha-numeric support identifier shall be included on these documents. The working drawings and computations shall be prepared in Customary U.S. units.

The packaged set of working drawings and computations for each span pole foundation shall be submitted in an individual file in electronic portable document format (.pdf) with appropriate bookmarks and commenting enabled. The packaged set shall include the following:

- title sheet
- table of contents
- contact information for designer – contact information should include name and address of design firm, name of contact person with phone number and email address
- copy of the certificate of insurance
- foundation working drawings
- foundation design computations

The working drawings and design computations shall be **signed, dated and sealed** by a Professional Engineer licensed in the State of Connecticut, who shall also be available for consultation to interpret the computations and drawings, and to resolve any problems which may occur during the performance of the work. Each working drawing shall be signed, dated and sealed. The cover/first sheet for the computations shall be signed, dated and sealed.

The electronic portable document format (.pdf) working drawings shall be created on ANSI D (22" x 34") full scale (1" electronic file = 1" paper) sheets. (The purpose of creating the drawings on ANSI D sheets is so that the sheets may be printed/plotted at that size or smaller without loss of legibility.) Each drawing shall have a border and title block. Located in the lower right hand corner of the drawing adjacent to the title block, each drawing shall have a rectangular box, 2 ¼" wide x 1 ¾" high, for the reviewers stamp. On the ANSI D full scale



sheets, the minimum text height and width shall be 1/8". All letter characters shall be uppercase. The electronic files for the design computations, procedures and other supporting data shall be created on ANSI A (8 1/2" x 11") letter sheets.

The working drawings shall include complete details of all foundation components. The drawings shall include, but not be limited to the following:

- the project number, town and support identification number
- reference to the design specifications, including interim specifications
- material specifications for all components
- embedment depths for foundation in soil, rock and a combination of soil and rock
- anchor bolt details, including dimensions, embedment and projection

The design computations shall include, but not be limited to the following:

- the project number, town and support identification number
- references to design specifications, including interim specifications, and the applicable code section and articles
- description/documentation for all computer programs used in the design
- drawings/models of the foundation with dimensions, loads and references to the local and global coordinate systems used (as applicable), to facilitate review of the results
- traffic structure reactions of all group loads and load combinations
- soil and rock design parameters
- computations demonstrating the geotechnical and structural capacity of the drilled shaft is adequate for all group load combinations

The Contractor shall submit the packaged set of working drawings and calculations to the project's "Engineer of Record". The project's "Engineer of Record" is identified in the signature block on the span pole foundation contract plans. A copy of the transmittal shall be sent to the District Construction office administering the project.

Prior to excavating for the foundation, the Contractor shall submit the following:

**Reinforcing Steel Shop Drawings:** Based on the accepted foundation design, the Contractor shall prepare reinforcing steel shop drawings for each foundation in accordance with Subarticle 1.05.02-3. The drawings shall be reviewed and stamped approved (or approved as noted) by the foundation designer. Four copies of each reviewed and stamped drawing shall be submitted to the Engineer at the District Construction office. One copy of each reviewed and stamped drawing shall be submitted to the “Engineer of Record”.

**Concrete and Slurry Mix Designs:** The Contractor shall submit to the District Engineer the concrete mix design and the slurry mix design, including admixtures, for review.

**Foundation Construction Procedure:** The Contractor shall submit to the District Engineer a written foundation construction procedure outlining the equipment; drilling procedure for soil and rock, including removal of obstructions and removal of excavated spoils; temporary casing placement and removal; slurry placement; reinforcement, anchor bolt and conduit placement; and concrete placement required for the drilled shaft foundation construction for review. The procedure should include contingencies for the various soil, rock and subsurface water conditions that may be encountered during the foundation construction.

The Engineer will evaluate the foundation construction procedure for conformance with the contract documents and will then notify the Contractor of any additional information required and/or changes necessary to meet the contract requirements. All procedural approvals given by the Engineer shall be subject to trial in the field and shall not relieve the Contractor of the responsibility to satisfactorily complete the work as detailed in the plans and specifications. The Contractor shall not commence construction of the drilled shafts until the Engineer has accepted the foundation construction procedure.

Excavations required for shafts shall be performed through whatever materials are encountered, to the dimensions and elevations in the working drawings or as ordered by the Engineer. The methods and equipment used shall be suitable for the intended purpose and materials encountered. Shaft excavation may be performed by combinations of augering, rotary drilling, down-the-hole hammer, reverse circulation drilling, clamming, scraping, or other means approved by the Engineer. Generally, either the dry method, wet method, or temporary casing method may be used, as necessary, to produce sound, durable concrete foundation shafts free of defects. The Contractor shall select and use the method that is needed to properly accomplish the work, as determined by site conditions and subject to the approval of the Engineer. The Contractor is responsible for maintaining the stability of the shaft excavation during all phases of construction.

The dry method consists of drilling the shaft excavation, removing accumulated water and loose material from the excavation, and placing the shaft concrete in a relatively dry excavation. The

dry construction method shall be used only at sites where the groundwater table and site conditions are suitable to permit construction of the shaft in a relatively dry excavation, and where the sides and bottom of the shaft are stable and may be visually inspected prior to placing the concrete. The use of the dry construction method is permitted if less than one foot of water accumulates in the bottom of a hole without pumping over a one hour period, the excavation remains stable and any loose material and water can be removed prior to placement of concrete.

The wet construction method shall be used at sites where a dry excavation cannot be maintained for placement of the shaft concrete. Wet construction methods consist of using a mineral slurry to maintain stability of the hole perimeter while advancing the excavation to final depth, placing the reinforcing cage and shaft concrete. This procedure may require desanding and cleaning the slurry; final cleaning of the excavation by means of a bailing bucket, air lift, submersible pump or other devices; and placing the shaft concrete with a tremie. Unless it is demonstrated to the satisfaction of the Engineer that the surface casing is not required, temporary surface casings shall be provided to aid shaft alignment and position, and to prevent sloughing of the top of the shaft excavation. Surface casing is defined as the amount of casing required from the ground surface to a point in the shaft excavation where sloughing of the surrounding soil does not occur.

The temporary casing construction method shall be used at all sites where the dry or wet construction methods are inappropriate. Temporary casing construction method consists of advancing the excavation through caving material by the wet method. Temporary casing may be installed by driving or vibratory procedures in advance of excavation to the lower limits of the caving material. When a nearly impervious formation is reached, a casing is placed in the hole and sealed in the nearly impervious formation. After the drilling fluid is removed from the casing, drilling may proceed as with the dry method except that the casing is withdrawn when the shaft concrete is placed. If seepage conditions prevent use of the dry method, excavation is completed using the wet method. Temporary casing may be installed by driving or vibratory procedures in advance of excavation to the lower limits of the caving material. Slurry may be omitted if the casing can be installed with only minor caving of the hole.

If the Engineer determines that the foundation material encountered during excavation is unsuitable or differs from that anticipated in the design of the shaft, or if rock is encountered at an unanticipated elevation, the Contractor's foundation designer shall determine if the foundation embedment should be revised from that shown on the working drawings. If rock is encountered, the Engineer shall be notified to inspect and determine the elevation of the top of competent rock. Any revisions to the foundation embedment during construction shall be reviewed by the Engineer.

Excavated materials which are removed from the shaft excavation and any drilled fluids used shall be disposed of by the Contractor as directed by the Engineer and in accordance with Section 1.10.

Casings shall be metal, smooth, clean, watertight, and of ample strength to withstand both handling and driving stresses and the pressure of both concrete and the surrounding earth materials. The outside diameter of casing shall not be less than the specified size of the shaft.

Temporary casings shall be removed while the concrete remains workable (i.e., a slump of 4" or greater). Before the casing is withdrawn and while the casing is being withdrawn, a 5'-0" minimum head of fresh concrete in the casing shall be maintained so that all the fluid trapped behind the casing is displaced upward without contaminating the shaft concrete. The required minimum concrete head may have to be increased to counteract groundwater head outside the casing. Separation of the concrete by hammering or otherwise vibrating the casing, during withdrawal operations, shall be avoided. Casing extraction shall be at a slow, uniform rate with the pull in line with the shaft axis.

Slurry used in the drilling process shall be a mineral slurry. The slurry shall have both a mineral grain size that will remain in suspension and sufficient viscosity and gel characteristics to transport excavated material to a suitable screening system. The percentage and specific gravity of the material used to make the suspension shall be sufficient to maintain the stability of the excavation and to allow proper concrete placement. The level of the slurry shall be maintained at a height sufficient to prevent caving of the hole.

The mineral slurry shall be premixed thoroughly with clean fresh water at a temperature above 41° F and adequate time allotted for hydration prior to introduction into the shaft excavation. The elevation of the slurry within the shaft foundation shall be maintained within 24" of the top casing and at least 48" above the existing water level during drilling and until the concrete placement is essentially complete. The slurry properties shall be maintained at all times, including non-working periods and stoppages. The slurry shall be circulated and agitated, continuously if necessary, to maintain the slurry properties and to prevent it from setting up in the shaft.

The Contractor, in the presence of the Engineer, shall perform control tests on the slurry to ensure that the density, viscosity, and pH fall within the acceptable limits tabulated below. The Contractor shall provide all equipment required to perform the tests. If desanding is required, sand content shall not exceed 4% (by volume) at any point in the shaft excavation as determined by the American Petroleum Institute sand content test.

Range of Values (at 68°F)

<b>Property (Units)</b>	<b>Time of Slurry Introduction</b>	<b>Time of Concreting (in Hole)</b>	<b>Test Method</b>
Density (pcf)	64.3 to 69.1	64.3 to 75.0	Density Balance
Viscosity (seconds per quart)	28 to 45	28 to 45	Marsh Cone
pH	8 to 11	8 to 11	pH paper or meter

The control tests to determine unit weight (density), viscosity, and pH values of the slurry shall be done during the shaft excavation to establish a consistent working pattern.

Prior to placing shaft concrete, slurry samples shall be taken from the bottom and at intervals not exceeding 10'-0" for the full height of slurry. Any heavily contaminated slurry that has accumulated at the bottom of the shaft shall be eliminated. The mineral slurry shall be within specification requirements immediately before shaft concrete placement.

The hole shall be covered when left unattended.

After completing the shaft excavation, all loose material existing at the bottom of the hole shall be removed.

Prior to placing the reinforcement into the shaft, the Contractor, in the presence of the Engineer, shall determine the shaft dimensions, depth and alignment of the shaft. The concrete shaft shall not be out of plumb by more than ¼ inch per foot of depth. The Contractor shall provide all equipment necessary for checking the shaft excavation. The Engineer shall inspect the shaft and verify that it has been properly cleaned.

The reinforcing steel shall be fabricated and assembled in accordance with Article 6.02.03. All reinforcement shall be assembled with wire ties. Welding to assemble the reinforcement is not permitted.

Immediately after the shaft excavation has been inspected and approved by the Engineer and prior to placement of the concrete, the assembled reinforcing steel cage, including cage stiffener bars, spacers, centralizers, and other necessary appurtenances, shall be carefully placed into the shaft excavation as a unit. Dropping or forcing cages into the shaft will not be allowed. The reinforcing steel in the shaft shall be tied and supported so that the reinforcing steel will remain within allowable tolerances of its intended position until the concrete will support the reinforcing steel. When concrete is placed by tremie methods, temporary hold-down devices shall be used to prevent uplifting of the reinforcing steel cage during concrete placement. Concrete spacers or other approved noncorrosive spacing devices shall be used at sufficient intervals not exceeding 5'-0" along the shaft to insure concentric location of the cage within the shaft excavation. When the size of the longitudinal reinforcing steel is larger than a #8 bar, such spacing shall not exceed 10'-0". After placement of the reinforcing cage, the Engineer shall inspect the shaft to ensure that it has remained clean. If the inspection indicates that loose material has accumulated at the bottom of shaft excavation, the Contractor shall remove the reinforcing cage and reclean the shaft.

If directed by the Engineer, the top of the shaft shall be formed square with the length of the sides matching the diameter of the shaft.

Concrete construction shall conform to Subarticle 6.01.03-2,3,4,5 and 6 as amended herein.

Concrete shall be placed in the shaft excavation as soon as possible, but no more than 4 hours after completion of excavation and cleaning of the bottom of the excavation, and no more than 2 hours after placement of the reinforcing steel cage. Concrete shall be placed in a continuous operation to the top of the shaft. The concrete level shall be horizontal during the pouring

operations. Concrete placement shall continue after the shaft is full and good quality concrete is evident at the top of the shaft. The elapsed time from the beginning of concrete placement in the shaft to the completion of placement shall not exceed 2 hours.

In dry construction, concrete shall be placed in a single continuous operation with the flow of concrete down the center of the shaft excavation so as to consolidate the concrete on impact. During placement operations, the concrete is not permitted to hit the reinforcing steel. A dropchute, consisting of a hopper and flexible hose, may be used to direct the concrete down the center of the foundation and prevent the concrete from hitting the reinforcing steel. Accumulated water shall be removed before placing the concrete. At the time of concrete placement, no more than 2" of water may exist at the bottom of the excavation and loose sediment no more than ½" over one-half the base is acceptable.

In wet (slurry) construction, concrete is to be placed by the tremie method, where the concrete displaces the slurry from bottom of the excavation to the top. The concrete shall be placed through a top metal hopper and into a rigid leak-proof elephant trunk tremie tube, sufficiently large enough to permit free flow of concrete. The tremie tube shall be positioned so that it can be removed without disturbing the reinforcing. Initially, the discharge end of the tremie tube shall be sealed closed (plugged) to prevent slurry from entering the tube after it is placed in the excavation and before the tube is filled with concrete. After concrete placement has started, the tremie tube shall be kept full of concrete to the bottom of the hopper to maintain a positive concrete head. The flow of concrete shall be induced by slightly raising the discharge end of the tube, always keeping the tube end in the deposited concrete. No horizontal movement of the tremie tube will be permitted.

The shaft concrete shall be vibrated or rodded to a depth of 5'-0" below the ground surface except where soft uncased soil or slurry remaining in the excavation will possibly mix with the concrete.

Exposed concrete shall be cured and finished in accordance with Subarticle 6.01.03-7, 9 and 10.

Anchor bolt assemblies shall be embedded in the concrete as shown on the working drawings. A template plate shall be used to hold the anchor bolt assemblies, conduits and ground rod sleeve in the correct position. The anchor bolts shall be installed plumb.

All conduit ends terminating below grade shall be capped with a malleable iron caps. All above-grade conduit ends shall be terminated with an insulated bonding bushing with tinned insert.

Ground rod and ground wire shall be installed as shown on the plans.

No construction operations that would cause soil movement adjacent to the shaft, other than mild vibration, shall be conducted for at least 48 hours after shaft concrete has been placed.

The top of the foundations shall be backfilled and the adjacent disturbed ground surfaces restored to match the surrounding area after the concrete has cured and the forms are removed.

Placement of topsoil shall conform to Articles 9.44.01 and 9.44.03. Turf establishment shall conform to Article 9.50.03.

The span poles shall not be erected on the foundation until the concrete in the shaft has attained a 28 day compressive strength,  $f'_c$ , greater than or equal to 4,000 psi.

**Method of Measurement:** This work will be measured for payment by the number of foundation units, each completely installed and accepted.

The work to remove rock from the foundation excavation will be measured from the top of rock to the bottom of rock excavation.

**Basis of Payment:** The work will be paid for at the contract unit price each for "Traffic Control Foundation – Span Pole," completed and accepted in place, which price shall include all equipment, materials, tools and labor incidental to the subsurface exploration, design, fabrication, construction and disposal of drilling spoils, of the foundations at the locations specified on the plans.

Backfilling and restoration of adjacent ground surfaces (pavement, slope protection, topsoil and seed, etc.) in all areas disturbed by the work will not be paid for separately, but will be included as part of the work. The Engineer will determine the type, thickness and horizontal limits of the surfaces to be restored.

When rock is encountered within the limits of excavation, its removal will be paid for at the contract unit price per vertical foot for "Rock in Foundation Excavation," which price shall include any additional excavation to remove the rock and any additional concrete required to fill the excavation beyond the designed foundation hole dimensions. Rock, in so far as it applies to "Rock in Foundation Excavation," shall be defined as rock in definite ledge formation, boulders, or portions of boulders, cement masonry structures, concrete structures or Portland cement concrete pavement which has a cross-sectional area that exceeds 50% of the cross-sectional area of the designed foundation hole.

Pay Item  
Traffic Control Foundation – Span Pole

Pay Unit  
EA.

## **ITEM #1103022A – 30’ STEEL SPAN POLE**

**Description:** Work under this item shall consist of designing, fabricating and installing a steel span pole to carry traffic appurtenances (such as traffic signals, signs, etc.), of the type specified, on a prepared foundation, in accordance with the details shown on the plans, in accordance with these specifications and as ordered by the Engineer.

**Materials:** The tubular components, such as the pole and luminaire arm shall be made of steel with a minimum yield stress of 35,000 psi.

The structural plate components, such as the baseplates and handhole frames shall be made of steel that conforms to the requirements of ASTM A709, Grade 50T2.

Anchorage plates shall conform to the requirements of ASTM A709, Grade 50T2.

The steel for pole members and structural plate components, such as the baseplates and handhole frames, shall meet the following Charpy V-notch impact testing requirements:

<b>Yield Strength</b>	<b>Thickness in.</b>	<b>Minimum Test Value Energy ft.-lbs.</b>	<b>Minimum Average Energy, ft.-lbf</b>
$F_y \leq 36$ ksi	$\leq 4$	20	25 at 40°F
$36$ ksi $< F_y \leq 50$ ksi	$\leq 2$	20	25 at 40°F
$36$ ksi $< F_y \leq 50$ ksi	$2 < t \leq 4$	24	30 at 40°F
$50$ ksi $< F_y \leq 70$ ksi	$\leq 4$ (100)	28	35 at -10°F
Charpy V-notch sampling and testing shall be in accordance with AASHTO T243, “P” piece frequency.			

The non-structural components, such as hand hole covers, caps and anchor bolt covers, shall be made of steel with minimum yield stress of 36,000 psi.

The filler metal shall have a matching strength relationship with the base metal.

All high strength bolts shall conform to ASTM A325, Type 1. Nuts shall conform to ASTM A563, Grade DH. Circular, flat, hardened steel washers shall conform to ASTM F436. The bolts, nuts and washers shall be galvanized in accordance with ASTM A153 or ASTM B695, Grade 50. The nuts shall be overtapped to the minimum amount required for the bolt assembly and all surfaces of the nuts shall be lubricated with a lubricant containing a visible dye of any color that contrasts with the color of the galvanizing. The high strength bolts shall conform to the requirements of Subarticle M.06.02-3.



The anchor bolts shall conform to ASTM F1554, Grade 105. The nuts shall conform to ASTM A563, Grade DH. The washers shall conform to ASTM F436. The bolts, nuts and washers shall be galvanized in accordance with ASTM A153. The nuts shall be overtapped to the minimum amount required for the bolt assembly and all surfaces of the nuts shall be lubricated with a lubricant containing a visible dye of any color that contrasts with the color of the galvanizing. Prior to shipping the anchor bolts, the nuts and washers shall be installed by hand on the anchor bolts to ensure that the nuts can be run on the threads. Only anchor bolts on which the nuts are free running shall be shipped. The anchor bolts shall be shipped with the nuts and washers on the threads.

All steel components, including anchor bolts, shall be completely hot-dip galvanized, after fabrication, in accordance with ASTM A123 or ASTM A153, as applicable. Repairs to damaged areas of the hot-dip galvanized coatings shall conform to the requirements of ASTM A780 amended as follows:

Paints containing zinc dust, if used for repairs, shall contain either between 65% to 69% metallic zinc by weight or greater than 92% metallic zinc by weight in dry film.

The silicone sealant shall be a 1-component, 100% silicone sealant recommended for use with galvanized steel.

Neoprene gasket material for the access openings shall conform to ASTM D1056, Grade 2A2 or 2A3. Other grades of neoprene approved by the Engineer may be used.

Closed cell elastomer for sealing the space between the foundation and base plate shall conform to ASTM D1056, Grade 2A2 or 2A3 and shall have a pressure-sensitive adhesive backing on one side for adhesion to steel. Closed cell elastomer contained within the anchor bolt pattern shall not interfere with the anchor bolt leveling nuts and shall not block the opening in the base plate.

Bare copper grounding conductor shall be #8 AWG stranded bare copper wire conforming to M.15.13. The grounding bolt shall be stainless steel with a hex head.

All materials used in the finished structure shall be new. The use of materials that have been previously used in a structure or salvaged from a structure is not permitted.

The Contractor shall submit Certified Test Reports and Materials Certificates in conformance with Article 1.06.07 for the steel used for span pole members and structural plate components, high-strength bolts (including nuts and washers) and anchor bolts (including nuts and washers). The Certified Test Reports shall include the following:

- a. Mill test reports that indicate the place where the material was melted and manufactured.

- b. High-strength bolt test results for proof load tests, wedge tests, and rotational-capacity tests that indicate where the tests were performed, date of tests, location of where the components were manufactured and lot numbers.
- c. Galvanized material test results that indicate the thickness of the galvanizing.

Prior to incorporation into the work, the Contractor shall submit samples in conformance with Article 1.06.02 for the steel used for span pole members and components, high-strength bolts (including nuts and washers) and anchor bolts (including nuts and washers).

**Painting:**

After galvanizing, all exterior surfaces shall be coated with a urethane or triglycidyl isocyanurate (TGIC) polyester powder to a minimum film thickness of 2.0 mils. The coating shall be electrostatically applied and cured in a gas fired convection oven by heating the steel substrate to a minimum of 177 degrees Celsius (350 degrees Fahrenheit) and a maximum of 204 degrees Celsius (400 degrees Fahrenheit). The thermosetting powder resins shall provide both intercoat as well as substrate fusion adhesion that meets 5A or 5B classifications of ASTM D3359. The color finish coat shall be Black, Federal Standard #27038 conforming to specification TT-E-489. The Contractor shall submit a color sample for approval to:

James Stewart, P.E.  
Director of Public Works  
Borough of Naugatuck  
246 Rubber Avenue  
Phone (203) 720-7071  
Email: [jstewart@Naugatuck-CT.gov](mailto:jstewart@Naugatuck-CT.gov)

Prior to shipment, poles shall be cradled in a 303 mm (12 inch) rubberized foam base. Any coating damaged prior to or during the installation shall be repaired. Areas to be repaired shall be clean, dry, free from grease, oil, corrosion products and other contamination. If contaminated, power wash or scrub with stiff brush and clean water. Repair areas may be brushed or sprayed as appropriate. If the Contractor elects to spray he must provide overspray containment. The minimum containment shall conform to the requirements of SSPC guile 6 for the Class 3A level.

**Construction Methods:** The design and fabrication of the span pole, including its anchorage (into the foundation), shall conform to the requirements of the latest edition of the AASHTO Standard Specifications for Structural Supports for Highway Signs, Luminaires and Traffic Signals, including the latest interim specifications, available prior to the advertising date of the contract, amended as follows:

- The design wind speed shall be 120 mph. The computation of wind pressures in accordance with Appendix C is not permitted.
- The minimum design life for span poles shall be 50 years.

- The wind importance factor,  $I_r$ , for wind pressure shall be 1.00.
- The span pole shall be designed to support free swinging traffic signals and signs. The wind drag coefficient for traffic signals and luminaires shall be no less than 1.2.
- The maximum stress ratio (the ratio of the computed stress to the allowable stress) or combined stress ratio (CSR) in any span pole component due to each group load shall not exceed 0.85. The purpose for limiting the CSR is to allow for future additional appurtenance configurations.
- The span pole shall be designed to support a span wire with a sag no greater than 5% of the span.
- The maximum luminaire arm length shall be 20'-0".
- The maximum diameter of the pole at the base shall be 18".
- The minimum wall thickness of the pole shall be 5/16". The wall thickness of the pole shall be uniform throughout its length. The use of multiple plies (laminations) to obtain the required pole thickness is not permitted. The use of shop-fabricated stepped members is not permitted.
- The span pole shall be a tubular member with either a round or multisided cross-section. Multisided tubular members with other than 8, 12 or 16 sides are not permitted. Multisided tubular members with fluted sides are not permitted. The pole shall be fabricated with a taper (change in diameter).
- Multisided tubular members less than or equal to 13" in diameter shall have a minimum of 8 sides. Multisided tubular members greater than 13" in diameter and less than or equal to 18" in diameter shall have no less than 12 sides.
- Multisided tubular members shall have a minimum internal bend radius of 5 times the tubular member thickness or 1", whichever is greater.
- Slip-type field splices are not permitted in the pole.
- The pole may be fabricated with no more than 2 longitudinal seam welds. The seam welds shall be ground smooth and flush with the adjacent base metal.
- The longitudinal seam welds within 6" of the member ends shall be complete joint penetration groove welds.

- 100% of partial joint penetration longitudinal seam welds shall be non-destructively tested in accordance with the magnetic particle method. 100 % of complete joint penetration seam welds shall be non-destructively tested in accordance with the ultrasonic method.
- All tubular member to transverse plate connections shall be made with a complete joint penetration groove weld with or without a backing ring. Backing rings may be connected to the inside surface of the tubular member with a continuous fillet welds only in tubular members greater than or equal to 16" in diameter. 100% of the complete joint penetration groove welds shall be non-destructively tested by the ultrasonic method after fabrication and prior to galvanizing. 100% of the complete joint penetration groove welds shall also be non-destructively tested by the ultrasonic method for toe cracks after galvanizing. 100% of backing ring fillet welds shall be non-destructively tested by the magnetic particle method after fabrication prior to galvanizing. After galvanizing, at locations where the backing ring is not welded to the transverse plate or the tubular member, the joint between the backing ring and transverse plate or tubular member shall be sealed with silicone sealant to prevent the ingress of moisture.
- The strength of a connection made with a complete joint penetration groove weld shall be no greater than the strength of the base metal. In connections joining base metal with different yield strengths, the base metal with the lower yield strength shall govern the design.
- The use of stiffeners at tubular member to transverse plate connections is not permitted.
- The minimum base plate thickness shall no less than 2 ½" or at least as thick as the anchor bolt diameter, whichever is greater. The determination of the plate thickness in the tubular member to transverse plate connections shall consider the potential for the plate to warp due to the heat from welding. Consideration should be given to the use of thicker plates to allow for subsequent machining of warped plates to a flat surface so that removal of material will not compromise the required strength of the plate.
- The opening in the base plate shall be sized to allow for proper galvanizing and allow conduits projecting from the foundation to pass through it. The size of the opening shall be kept to a minimum to reduce the flexibility of the baseplate.
- The pole base plate anchor bolt circle diameter shall be 24".
- The anchor bolt to base plate connection shall be designed as a double-nut connection with shear holes. The minimum distance from the center of the anchor bolt hole to the edge of the base plate shall be no less than 2 times the diameter of the anchor bolt. The anchor bolts shall use an embedded anchorage plate, ½"

minimum thickness, to transmit loads from the pole base to the concrete foundation. The use of hooked anchor bolts is not permitted. The minimum number of anchor bolts shall be 8. The minimum anchor bolt diameter shall be 2". The minimum anchor bolt embedment, the distance from the top of the foundation to the top of the embedded anchorage plate, shall be 3'-6" or the tension development length of the vertical foundation reinforcement plus the end concrete cover, whichever is greater. Each anchor bolt shall be supplied with 4 nuts and 4 washers. Washers shall be placed on the top and bottom surfaces of the pole base plate and anchorage plate. Welding to the anchor bolts is not permitted. The use of lock washers with the anchor bolt assembly is not permitted.

- The span wire pole clamp shall be designed to support a minimum tensile force of 12,000 pounds or 3 times the maximum calculated tensile force in the span wire, whichever is greater.

The span pole shall be designed for the load effects due to the span wire(s) attached to the poles and all the traffic appurtenances (signals, signs, luminaires, cameras, etc.) attached to the span wire and the pole. The load effect due to the span wire, resulting from the attached traffic appurtenances, will not be provided and shall be determined by the Contractor. The span pole shall also be designed for load effects from future traffic appurtenances arranged, positioned and located as shown on the plans. The span pole shall also be designed for load effects during all stages of construction that may exist during the project under which the span pole is installed. The span pole shall be designed to support traffic appurtenances with properties no less than those tabulated on the plans.

The locations and dimensions of the span poles are shown on the traffic plans. The luminaire arm and pole lengths and the attachment heights shall be verified by the Contractor based on the finished grade at the site, top of foundation elevation, the locations of overhead utility cables and the traffic appurtenance mounting heights. If either the wire or pole length is inadequate, the Contractor shall notify the Engineer.

The minimum vertical clearance from the top of the finished road to the bottom of the traffic signals shall be 16'-0". The maximum vertical clearance from the top of the finished road to the bottom of the traffic signals shall be 18'-0". The traffic signals shall be installed so that the bottom of all the signals for each approach is at the same elevation.

Vent and drain holes shall be provided for galvanizing. The number, size and location of vent and drain holes shall be coordinated with the galvanizer prior to the submission of the working drawings and design computations. The area of vent and drain holes at each end of a member shall be at least 30% of the inside area of the member for members 3" in diameter and greater and 45% of the inside area of the member for members smaller than 3" in diameter. The vent and drain holes shall be strategically located for reducing stress and for proper galvanizing. The holes shall be made by drilling. Flame cut holes are not permitted. The edges of all holes shall

be rounded by grinding. After galvanizing, exposed holes placed in the sign support components for galvanizing shall be sealed with neoprene plugs.

A J-hook shall be welded to the inside of the pole at the top for wire handling and support.

The span pole shall have a handhole, reinforced with a frame, located at the base of the pole. The handhole shall be located with a normal direction that is 90° to the plane formed by the pole and span wire. The minimum clear distance from the top of the baseplate to the outside face of the bottom of the handhole frame shall be no less than the diameter of the tubular member or 1'-3", whichever is greater. The handhole frame shall have a minimum 4" wide by minimum 6" high clear opening. The maximum width of the handhole opening, the clear opening plus twice the frame thickness, shall not be greater than 40% of the tubular member diameter at that section. The inside corners of the handhole frame shall be rounded to a radius of 30% to 50% of the width of the clear opening. The minimum thickness of the handhole frame shall be no less than the thickness of the pole or 5/16", whichever is greater. The handhole frame shall be connected to the pole with a partial joint penetration groove weld reinforced with a fillet weld. The handhole weld shall start and end at the point that is coincident with the longitudinal axis of symmetry of the tubular member and the longitudinal axis of symmetry of the handhole frame. 100% of each handhole weld shall be non-destructively tested in accordance with the magnetic particle method. The handhole shall be provided with a cover connected to the frame with no less than 2 stainless steel screws. The cover shall be installed with a neoprene gasket matching the dimensions of the cover. Cover and the gasket; and the gasket and the handhole frame shall be in firm and continuous contact after tightening the fasteners. The cover shall also be attached to the frame with a 1'-6" long stainless steel chain. The inside bottom of the frame shall have a hole tapped for the stainless steel grounding bolt.

The span pole shall include wire entrance fittings. The number and size of the wire entrance fittings shall be as shown on the plans. The fittings shall be welded, all-around, to the pole at a 45-degree angle to the pole.

The span pole shall be supplied with a pole cap plate and anchor bolt covers. The cap plates shall be attached with fasteners. The joint between the tubular member and plate shall be sealed with a neoprene gasket matching the dimensions of the plate.

The luminaire arms shall be fabricated of pipe with a minimum thickness equal to schedule 40. Single arm luminaires shall be used for luminaires with arm lengths less than or equal to 8'-0". Truss type luminaires shall be used for luminaires with arm lengths greater than 8'-0". The truss type luminaires shall consist of an upper and lower members joined with vertical members at the tip and midspan. To accommodate the luminaire fixture, the size of the pipe in the luminaire arm at the tip shall be 2" diameter, schedule 40. If necessary, a reducing tenon shall be installed at the tip of the arm to accommodate the luminaire fixture.

The luminaire arm(s) shall be connected to the pole with clamp connections. Each clamp connection shall use 4 high-strength bolts. The installed nuts shall be prevented from loosening while in service. The use of lock washers to meet this requirement is not permitted. The arms

shall be fillet welded, all-around, to the clamp(s). The size of the weld shall be no less than ¼". A hole shall be provided in the clamp, (upper arm clamp for truss type arms) and pole to allow for wires to pass from the pole to the luminaire arm. The sides of all holes in the connection shall be ground smooth and edges rounded by grinding to prevent the wires from chafing.

Prior to fabrication, the Contractor shall submit working drawings and design computations for each span pole to the Engineer for review in accordance with Article 1.05.02. An individual, independently packaged set of working drawings and computations, with all details and documents necessary for fabrication and erection of the structure and its components, including a copy of the certificate of insurance, shall be prepared and submitted for **each** span pole. **A single set of drawings with tabulated data for multiple span pole locations is not permitted.** The alpha-numeric span pole identifier shall be included on these documents. The working drawings and computations shall be prepared in Customary U.S. units.

The packaged set of working drawings and computations for each span pole shall be submitted in an individual file in electronic portable document format (.pdf) with appropriate bookmarks and commenting enabled. The packaged set shall include the following:

- title sheet
- table of contents
- contact information for designer, fabricator and galvanizer – contact information should include name and address of each firm and the name of contact person with phone number and email address
- copy of the certificate of insurance
- copy of fabricator's AISC certification
- copy of the traffic signal control plan detailing the span pole
- span pole working drawings
- span pole design computations
- welding procedures
- span pole installation procedure, including the method to plumb the pole

The working drawings and design computations shall be **signed, dated and sealed** by a Professional Engineer licensed in the State of Connecticut, who shall also be available for consultation to interpret the computations and drawings, and to resolve any problems which may occur during the performance of the work. Each working drawing shall be signed, dated and sealed. The cover/first sheet for the computations shall be signed, dated and sealed.

The electronic portable document format (.pdf) working drawings shall be created on ANSI D (22" x 34") full scale (1" electronic file = 1" paper) sheets. (The purpose of creating the drawings on ANSI D sheets is so that the sheets may be printed/plotted at that size or smaller without loss of legibility.) Each drawing shall have a border and title block. Located in the lower right hand corner of the drawing adjacent to the title block, each drawing shall have a rectangular box, 2 ¼" wide x 1 ¾" high, for the reviewers stamp. On the ANSI D full scale sheets, the minimum text height and width shall be 1/8". All letter characters shall be uppercase.

The electronic files for the design computations, procedures and other supporting data shall be created on ANSI A (8 ½" x 11") letter sheets.

The working drawings shall include complete details of all span pole components. The drawings shall include, but not be limited to the following:

- the project number, town and span pole identification number
- reference to the design specifications, including interim specifications
- reference to the design specifications design criteria, such as design wind speed, minimum design life, vehicle speed, etc.
- material specifications for all components
- material designations for the pole, with an explanation of the alpha numeric characters (equivalent thickness, in inches, shall be provided for gage numbers)
- non-destructive weld testing requirements
- details of the location of the longitudinal seam weld(s) in the pole
- vent and drain holes for galvanizing
- a plan view of the anchor bolt layout relative to the orientation of the wire
- anchor bolt dimensions, including embedment and projection
- span pole installation procedure, including the method to plumb the pole

The design computations shall include, but not be limited to the following:

- the project number, town and alpha-numeric span pole identifier
- references to design specifications, including interim specifications, and the applicable code section and articles
- description/documentation for all computer programs used in the design
- drawings/models of the structure, components and connections, with dimensions, loads and references to the local and global coordinate systems used (as applicable), to facilitate review of the results



- a tabulation of the section properties of the tubular members at each analyzed section. The tabulated values should include the diameter,  $D$  (if round member); effective width,  $b$  (if multisided member, AASHTO 5.5.2); equivalent diameter (if multisided member, AASHTO 5.6), wall thickness,  $t$ ; inside bend radius,  $r_b$  (if multisided member, AASHTO 5.5.2), cross-sectional area,  $A$ ; moment of inertia,  $I$ ; section modulus,  $S$ ; radius of gyration,  $r$ . AASHTO Table B-1 may be used to determine the section properties. If Table B-1 is used, the radius measured to the mid-thickness of the wall shall also be provided.
- coefficients and factors used in the design
- results of all group loads and load combinations
- stress ratios and combined stress ratios for all group loads and load combinations
- horizontal due to Group Load Combinations I, II and III for dead, wind and ice loads

The Contractor shall submit the packaged set of working drawings and calculations to the project's "Engineer of Record". The "Engineer of Record" is identified in the signature block on the span pole contract plans.

The span poles shall be fabricated in accordance with the latest edition of the AASHTO LRFD Bridge Construction Specifications, including the latest interim specifications, amended herein.

The steel fabricator shall be AISC certified for the fabrication to the Standard for Bridge and Highway Metal Component Manufacturers (CPT).

Fabrication of the span pole may begin only after the working drawings and design computations have been reviewed and the Engineer has authorized fabrication to begin. The Contractor shall submit to the Engineer, no less than 2 weeks prior to the start of fabrication, the name and location of the fabrication shop where the work will be done so that arrangements can be made for an audit of the facility and the assignment of the Department Quality Assurance (QA) inspector. No fabrication will be accepted unless the QA inspector is present during fabrication. No changes may be made during fabrication without prior written approval by the Department.

The Contractor shall furnish facilities for the inspection of material and workmanship in the shop by the Engineer. The Engineer and his representative shall be allowed free access to the necessary parts of the premises.

The Engineer will provide QA inspection at the fabrication shop to assure that all applicable Quality Control plans and inspections are adequately adhered to and maintained by the Contractor during all phases of the fabrication. A thorough inspection of a random selection of elements at the fabrication shop may serve as the basis of this assurance.

Prior to shipment to the project, each individual piece of steel shall be marked in a clear and permanent fashion by a representative of the fabricators' Quality Control (QC) Department to indicate complete final inspection by the fabricator and conformance to the project specifications for that piece. The mark must be dated. A Materials Certificate in accordance with Article 1.06.07 may be used in lieu of individual stamps or markings, for all material in a single shipment. The Materials Certificate must list each piece within the shipment and accompany the shipment to the project site.

Following the final inspection by the fabricator's QC personnel, the Engineer may select pieces of steel for re-inspection by the Department's QA inspector. Should non-conforming pieces be identified, all similar pieces must be re-inspected by the fabricator and repair procedure(s) submitted to the Engineer for approval. Repairs will be made at the Contractor's expense.

The pieces selected for re-inspection and found to be in conformance, or adequately repaired pieces, may be marked by the QA inspector. Such markings indicate the Engineer takes no exception to the pieces being sent to the project site. Such marking does not indicate acceptance or approval of the material by the Engineer.

All welding details, procedures and nondestructive testing shall conform to the requirements of AWS D1.1 Structural Welding Code - Steel.

Personnel performing the nondestructive testing shall be certified as a NDT Level II technician in accordance with the American Society for Non Destructive Testing (ASNT), Recommended Practice SNT-TC-1A and approved by the Engineer.

All nondestructive testing shall be witnessed by Engineer. Certified reports of all tests shall be submitted to the Engineer for examination. Each certified report shall identify the structure, member, and location of weld or welds tested. Each report shall also list the length and location of any defective welds and include information on the corrective action taken and results of all retests of repaired welds.

The Department reserves the right to perform additional testing as determined by the Engineer. Should the Engineer require nondestructive testing on welds not designated in the contract, the cost of such inspection shall be borne by the Contractor if the testing indicates that any weld(s) are defective. If the testing indicates the weld(s) to be satisfactory, the actual cost of such inspection will be paid by the Department.

All members and components shall be hot-dip galvanized in a single dip. Double-dipping of members and components is not permitted. All exterior and interior surfaces of the span pole members and components, shall be completely galvanized.

Galvanized members and components shall be free from uncoated areas, blisters, flux deposits, and gross inclusions. Lumps, projections, globules, or heavy deposits of zinc which will interfere with the intended use of the material will not be permitted.

After galvanizing, at locations where the backing ring is not welded to the transverse plate or the tubular member, the joint between the backing ring and transverse plate or tubular member shall be sealed with silicone sealant to prevent the ingress of moisture.

All damaged areas of the hot-dip galvanized surfaces shall be repaired in accordance with the requirements of ASTM A780. If paint containing zinc dust is used for repairs, the dry coating thickness shall be at least 50% greater than the thickness of the adjacent hot-dip galvanized coating, but no greater than 4.0 mils. The paint shall be brush applied. The use of aerosol spray cans shall not be permitted. The color of the finished repair area shall match the color of the adjacent hot-dip galvanized surface at the time of the repair to the satisfaction of the Engineer.

Prior to shipping, all exterior and interior galvanized surfaces of the members and components shall be inspected, in the presence of the Engineer, to determine the acceptability of the galvanized coating. Galvanized coatings may be found acceptable by the Engineer if all surfaces of the members and components meet the galvanizing requirements herein. Only span pole members and components with acceptable galvanized coatings shall be shipped. If the galvanized coating on any member or component is found not acceptable, the Contractor shall submit a repair procedure to the Engineer for review.

After fabrication and prior to shipping, aluminum identification tags shall be attached to the span poles with self-tapping tamper resistant screws.

The finished members and components shall be protected with sufficient dunnage and padding to protect them from damage and distortion during transportation. Damage to any material during transportation, improper storage, faulty erection, or undocumented fabrication errors may be cause for rejection of said material at the project site. All costs associated with any corrective action will be borne by the Contractor.

Following delivery to the project site, the Engineer will perform a visual inspection of all material to verify shipping documents, fabricator markings, and that there was no damage to the material or coatings during transportation and handling.

The Engineer is not responsible for approving or accepting any fabricated materials prior to final erection and assembly at the project site.

High-strength bolts, nuts and washers shall be stored in accordance with Subarticle 6.03.03-4(f).

The span pole shall be erected, assembled and installed in accordance with these specifications and the procedures and methods submitted with the working drawings. The Contractor and the span pole designer are responsible to ensure that the erection and assembly procedures and methods in this specification are acceptable for use with the span pole. Changes to these method and procedures shall be submitted with the working drawings and computations.

Prior to installation of the span pole, the exposed threads of all the embedded anchor bolts shall be cleaned of accumulated dirt and concrete and lubricated. The threads and bearings surfaces of

all the anchor bolt nuts shall be cleaned and lubricated. The anchor bolts and nuts are properly lubricated if the nuts can be turned by hand on the anchor bolt threads. The lubricant shall contain a visible dye of any color that contrasts with the color of the galvanizing. Re-lubricate the threads of the anchor bolts and nuts if more than 24 hours has elapsed since earlier lubrication, or if the anchor bolts and nuts have become wet since they were first lubricated.

Install (turn) the leveling nuts onto the anchor bolts and align the nuts to the same elevation or plane. The distance from the bottom of the leveling nuts to the top of the foundation shall not exceed 1". Place a structural hardened washer on top of each leveling nut, 1 washer on each anchor bolt.

Prior to erecting the pole, place the closed cell elastomer ring within the anchor bolt pattern. The closed sell elastomer ring shall not interfere with the anchor bolt leveling nuts and shall not block the opening in the base plate.

The pole shall be erected so that the centerline of the pole will be plumb after the application of all the dead loads. The pole may be initially installed raked in the opposite direction of the overhead member to obtain the plumb condition. Raking the pole may be accomplished by installing the leveling nuts in a plane other than level.

Install the pole base plate atop the washers resting on the leveling nuts, place a structural hardened washer on each anchor bolt resting it on the top of the base plate, and install (turn) a top nut on each anchor bolt until the nut contacts the washer. The leveling nuts and washers shall be inspected, and if necessary the nuts (turned), so that the washers are in full contact with the bottom surface of the base plate.

Tighten the top nuts to a snug tight condition in a star pattern. Snug tight is defined as the maximum rotation resulting from the full effort of one person using a 12" long wrench or equivalent. A star tightening pattern is one in which the nuts on opposite or near-opposite sides of the bolt circle are successively tightened in a pattern resembling a star (e.g., For an 8-bolt circle with bolt sequentially numbered 1 to 8, tighten nuts in the following bolt order: 1, 5, 7, 3, 8, 4, 6, 2.).

Tighten leveling nuts to a snug tight condition in a star pattern.

Before final tightening of the top nuts, mark the reference position of each top nut in a snug-tight condition with a suitable marking on 1 flat with a corresponding reference mark on the base plate at each bolt. Then incrementally turn the top nuts using a star pattern one-sixth of a turn beyond snug tight. Turn the nuts in at least two full tightening cycles (passes). After tightening, verify the top nut rotation. The top nuts shall have full thread engagement. The distance from the bottom of the leveling nuts to the top of the foundation shall not exceed 1".

After erecting the span pole, the span pole shall be electrically grounded by attaching the bare copper grounding conductor to the inside of the handhole frame with a stainless steel bolt and to the ground rod with a ground clamp. The rigid metal conduit shall be electrically grounded by

attaching the bare copper grounding conductor to the insulated bonding bushing and to the ground rod with a ground clamp.

The traffic appurtenances shall be located and mounted on the wire as shown on the cross-sections. A span wire pole clamp shall be provided for each span wire connected to the pole.

After installation of the traffic appurtenances, the anchor bolt nuts (leveling and top anchor nut) and washers shall be in full contact with the top and bottom surfaces of the pole base plate and the centerline of the pole shall be plumb.

After installation of the traffic appurtenances, a survey shall be performed by the Contractor to confirm that the sag is no less than 5% of the span and to confirm that the minimum vertical clearances from the top of the finished road to the bottom of the traffic appurtenances have been met.

The last character of the span pole identification number shall be stenciled with black paint, unless otherwise specified, on the pole of each span pole. The character shall be 3" high and placed approximately 12" above the top of the base plate facing the centerline of the roadway.

**Method of Measurement:** This work will be measured for payment by the number of span poles, of the type specified, completed and accepted in place.

**Basis of Payment:** This work will be paid for at the contract unit price each for "XX Steel Span Pole" or "Steel Combination Span Pole", of the type specified, complete in place, which price shall include all equipment, materials, tools and labor incidental to the design, fabrication and installation, of the span pole at the locations specified on the plans.

<u>Pay Item</u>	<u>Pay Unit</u>
30' Steel Span Pole	EA.

**ITEM #1105003A - 1 WAY, 3 SECTION SPAN WIRE TRAFFIC SIGNAL**

**ITEM #1105007A - 2 WAY, 3 SECTION SPAN WIRE TRAFFIC SIGNAL**

**ITEM #1105180A - 1 WAY, 1 SECTION BI-COLORED ARROW**

**Article 11.05.03 – Construction Methods:**

Add the following paragraph:

Circular indications that have an identification mark (such as an arrow) on the top of the lens shall be installed with that mark at the 12 o'clock position.

**Article M.16.06 - Traffic Signals**

**Sub Article 3 - Housing:**

In the last sentence, between the words “housing” and “shall” add “and all internal hardware”.

Add the following after the last paragraph.

Each section of the housing shall be provided with a removable visor. The visor shall be the cap type, unless otherwise noted on the plan. The visor shall be a minimum .05 inch (.13 mm) thick. The visor shall be the twist on type and secured to the signal by four equidistant flat tabs screwed to the signal head.

**Sub Article 4 - Brackets:**

Add the following at the end of the last paragraph:

Install a 2” wide yellow retroreflective strip (Type IV sheeting) along the perimeter of the face of the backplate.

**Delete Sub Article 5 - Optical Unit and Sub Article 6 – Lamp Socket and replace with the following:**

Optical Unit, Light Emitting Diode:

**(a) General:**

Only Optical Units that meet the requirements contained herein supplied by the below manufacturers that have been tested by the Department's Signal Lab will be accepted. Final approval for model numbers will be done at the time of the catalog cut submittals.

Duralight  
Trastar, Inc.  
860 N. Dorothy Dr., Suite 600  
Richardson, TX 75081

GE Lighting Solutions  
Corporate Headquarters  
1975 Noble Road Building 338E  
East Cleveland, OH 44112-6300

Dialight  
1501 Foute 34 South  
Farmingdale, NJ 07727

Leotek  
726 South Hillview Drive  
Milpitas, CA 95035

The materials for Light Emitting Diode (LED), Optical Unit, circular and arrow, shall conform to the following:

- The ITE Performance Specification for Vehicle Traffic Control Signal Heads – Light Emitting Diode (LED) Circular Signal Supplement for circular indications dated June 27, 2005.
- The ITE Performance Specification for Vehicle Traffic Control Signal Heads – Light Emitting Diode (LED) Vehicle Arrow Traffic Signal Supplement for arrow indications dated July 1, 2007.

Section 4, Adjustable Traffic Signals and General Housing sections of the **Department of Transportation Functional Specifications for Traffic Control Equipment, current edition governs**. Where the Department of Transportation Functional Specifications conflict with this Special Provision or the 2005/2007 ITE Performance Specifications, this Special Provision and the 2005/2007 ITE Performance Specifications shall govern.

The Optical Unit shall have an Incandescent look and be made up of a smooth surfaced outer shell, multiple LED light sources, a filtered power supply and a back cover, assembled into a sealed unit. The Optical Unit shall be certified as meeting the 2005/2007 ITE Specifications by Intertek Testing Services, Inc. (ITSNA, formerly ETL) or another organization currently recognized by the Occupational Safety and Health Administration (OSHA) as a Nationally Recognized Testing Laboratory (NRTL.) The Optical Unit shall perform to the requirements of the ITE Specification for a minimum of 60 months.

A "Swing Test" will be performed by the Department to ensure no significant dimming or blanking occurs, until the lamp is obscured by the visor. All L.E.D Lamps will be subjected to further field testing for reliable operation.

The Arrow Optical Unit shall be “Omni-Directional” so that it may be oriented in a right, left or straight configuration without degradation of performance.

**(b) Electrical Requirement:**

**Operating voltage:**

80 to 135 Volts AC with cutoff voltage (no visible indication) below 35Volts AC.

**Power requirements:**

Circular Indications: 12”, (300 mm) – no more than 16 Watts

Circular Indications: 8”, (200mm) - no more than 16 Watts

Arrows Indications: 12”, (300mm) - no more than 16 Watts

**Power Supply:**

Fused and filtered to provide excess current protection and over voltage protection from electrical surges and transient voltages.

**(c) Photometric Requirement:**

**Beam Color:**

Meet 2005/2007 ITE Specifications

**(d) Mechanical Requirements:**

**Diameter:**

The Circular Optical Unit shall fit into standard 12” (300mm) or 8” (200mm) housing.

The Arrow Optical Unit shall fit 12” (300mm) housings only.

**Enclosure:**

UV (Ultraviolet) stabilized polycarbonate back cover.

Clear lens cover for all Red, Yellow and Green Circular Optical Units.

For Arrow Optical Units the arrow indication segment of the lens shall be clear.

Enclosure sealed and waterproofed to eliminate dirt contamination and be suitable for installation in all weather conditions.

Clearly mark on the housing the following information:

- Manufacturer & model number
- Date of manufacture (must be within one year of installation)

The model number shall end with the number of LEDs used to comprise the unit as the last digits of the model number. Example, if the unit comprised of 3 LEDs and the model is x12y, then the new model number shall read x12y3.

**Operating temperature:**

Meet 2005/2007 ITE Specification

**Wiring:** L.E.D. lamps shall have **color coded 16 AWG wires** for identification of heads as follows:

RED L.E.D. Lamps	RED with WHITE neutral
------------------	------------------------



YELLOW L.E.D. Lamps	YELLOW with WHITE neutral
GREEN L.E.D. Lamps	GREEN or Brown with WHITE neutral
RED L.E.D. ARROWS	RED/WHITE with WHITE neutral
YELLOW L.E.D. ARROWS	YELLOW/WHITE with WHITE neutral
GREEN L.E.D. ARROWS	GREEN/WHITE or BROWN/WHITE with WHITE neutral
GREEN/YELLOW L.E.D ARROWS	GREEN/WHITE or BROWN/WHITE, YELLOW/WHITE, with WHITE neutral

Wires shall be terminated with a Block Spade, 6-8 stud/ 16-14 wire size.

All Circular Optical Units shall be supplied with a minimum 40" pigtail and all Arrow Optical Units Supplied with a minimum 60" pigtail.

**Sub Article 9 - Painting:**

**Third coat:** Replace the first two sentences with the following:

All brackets and hardware shall be painted black by the manufacturer. The color shall be Federal Standard No. 27038 conforming to Federal specification TT-E-489.

## **ITEM#1106001A- 1 WAY PEDESTRIAN SIGNAL POLE MOUNTED**

## **ITEM#1106003A- 1 WAY PEDESTRIAN SIGNAL PEDESTAL MOUNTED**

### **Section 11.06.02 Pedestrian Signal, Materials**

#### Section M.16.07 C. Optical Unit

Delete 2. LED: and replace with the following:

##### General

- Meet requirements of current MUTCD Section 4E.
- Meet current ITE specifications for Pedestrian Traffic Control Signal Indications - (PTCSI) Part 2: Light Emitting Diode (LED).
- Meet CT DOT, 2008 - 2010 Functional Specifications for Traffic Control Equipment; Section 5D, LED Pedestrian Signal with Countdown Timer.
- Meet EPA Energy Star® requirements for LED Pedestrian Signal Modules.

##### Operational

- Countdown display only during the flashing Pedestrian Clearance (Ped Clr) Interval. Timer goes blank at end of flashing ped clr even if countdown has not reached zero.

##### Physical

- Sealed optical module to prevent entrance of moisture and dust.
- Self-contained optical module, including necessary power supplies.
- Designed to securely fit into standard housing without the use of special tools or modifications to the housing.
- Identification information on module: manufacturer's name, model number, serial number, and date code.

##### Optical

- Multiple LED sources; capable of partial loss of LED's without loss of symbol or countdown message.
- Two complete self contained optical systems. One to display the walking person symbol (walk) and the hand symbol (don't walk). One to display the countdown timer digits.
- Visual Image similar to incandescent display; smooth, non-pixelated.
- Symbol and countdown digit size as shown on the plan.
- Solid hand/person symbol; outline display not allowed.
- Overlaid hand/person symbols and countdown digits arranged side by side.
- Countdown digit display color: Portland Orange in accordance with ITE requirements.
- Countdown digits comprised of two seven segments, each in a figure 8 pattern.
- Photometric Requirements: Luminance, Uniformity, and Distribution in accordance with ITE requirements.
- Color Uniformity in accordance with ITE requirements.
- Blank-Out design; symbols and digits illegible even in direct sunlight when not illuminated.

#### Electrical

- Operating voltage: 89 VAC to 135 VAC.
- Low Voltage Turn-Off: 35 VAC.
- Turn-On and Turn-Off times in accordance with ITE specifications.
- Combined Hand – Countdown Digits wattage:  $\geq 20$  Watts.
- Input impedance at 60 Hertz sufficient to satisfy Malfunction Management Unit (MMU) requirements.
- Two separate power supplies. One to power the walking person symbol. One to power the hand symbol and the countdown digits.
- Meet Federal Communication Commission (FCC) regulations concerning electronic noise.
- Filtered and protected against electrical transients and surges.

#### Warranty

- Five years from date ownership is accepted.

#### Section M.16.07 F. Painting:

**Third coat:** Replace the first two sentences with the following:

All brackets and hardware shall be painted black by the manufacturer. The color shall be Federal Standard No. 27038 conforming to Federal Specification TT-E-489.

## **ITEM #1107011A - ACCESSIBLE PEDESTRIAN SIGNAL AND DETECTOR (TYPE A)**

### **Description:**

Furnish and install an Accessible Pedestrian Signal and Detector (APS&D). The APS&D provides audio and tactile information to augment the visual pedestrian signal.

Type A provides a low frequency percussive tone during the walk interval and is used where there is an exclusive pedestrian phase or  $\geq 10$  foot separation between APS&Ds.

### **Material:**

#### **A. General:**

- Conform to applicable sections of the current MUTCD Chapter 4E, Pedestrian Control Features as specified herein.
- All features fully operational when the traffic signal is in colors mode.
- All features non-operational when the traffic signal is in flash mode.
- Interchangeable with a non-accessible type pedestrian pushbutton with no modifications to the Controller Assembly (CA) or Controller Unit.
- Audible transducer integral with the APS&D housing, adjacent to the pushbutton.
- Operation programming method: Either or combination of:
  - Mechanically by dip switches or circuit board jumpers
  - Infrared remote-control hand-held device

#### **B. Electrical:**

- Metallic components either grounded or insulated to preclude an electrical hazard to pedestrians under all weather conditions.
- All features powered by the 110VAC Walk signal and the 110VAC Don't Walk signal so that additional conductors from the CA are not needed.

#### **C. Audible Pushbutton Locator Tone**

- Frequency: repeating tone at one (1) second intervals
- Tone duration:  $\leq 0.15$  seconds
- Volume:
  - Minimum setting of zero
  - Manually adjustable initial setting
  - Automatically adjusted after initial setting. Volume increased in response to a temporary increase in ambient noise and subsequently decreased with a decrease in ambient noise.
  - Maximum volume: 100 dBA which is the approximate sound pressure of a gasoline powered lawn mower nearby.
  - Automatic volume adjustment independent of other APS&Ds at the intersection.
  - May be disabled without affecting operation of other features.
- Silent only during walk interval. Active all other times.

#### **D. Vibrotactile Arrow Pushbutton**

- Pushbutton contained in a circular assembly which fits inside the housing and is attached to the housing with 4 screws.
- Actuation of pushbutton initiates speech message "Wait".
- ADA compliant: Size:  $\geq 2.0$ " (50) diameter, Actuation force:  $\leq 5$  ft-lb (22.2 N)

- Shape: Circular, raised slightly above housing so that it may be actuated with the back of a hand
- Tamper-proof, vandal-proof, weatherproof, freeze-proof, impact-resistant design and construction.
- Operation: Vibrates only during the walk interval (when the walk indication is displayed).
- Tactile Arrow:
  - Attached to surface of the button assembly by a tamperproof method.
  - Raised slightly above surface of pushbutton, minimum 0.125" (0.3)
  - Size: Length  $\geq$  1.5" (38), Height  $\geq$  1.0" (25)
  - Color: Sharp contrast to background color of pushbutton and housing

#### E. Audible Walk Interval

##### 1. General:

- Operation independent of other APS&Ds at intersection.
- Active only during the walk interval (when the walk indication is displayed).
- Volume:
  - Minimum setting of zero
  - Manually adjustable initial setting
  - Automatically adjusted after initial setting. Volume increased in response to a temporary increase in ambient noise and subsequently decreased with a decrease in ambient noise.
  - Automatic volume adjustment independent of other APS&Ds at the intersection.
  - Maximum volume: 100 dBA which is the approximate sound pressure of a gasoline powered lawn mower nearby.
- Duration:
  - Default method: Automatically set by the duration of the visual walk signal display.
  - When selected: Manually set when rest-in-walk is used for a concurrent pedestrian movement.
- Audible sounds that mimic any bird call are not allowed.

##### 2. Type A, Percussive Tone:

- Repeating tone at eight (8) to ten (10) ticks per second.
- Tone frequency: Multiple frequencies with a dominant component at 880 Hz which creates a "tick - tick - tick..." sound.

#### F. Pushbutton Housing/Sign Frame/Sign

- One piece die cast aluminum meeting requirements of ASTM B85.
- Sign frame designed to accept 9" x 12" (230 x 300) four-hole advisory sign.
- Flat back to facilitate surface mount.
- Available brackets to either pedestal top-mount or pole side-mount on pole diameter range of 3½" (89) to 15" (380).
- Available brackets to allow mounting two (2) APS&Ds to the same 3½" (89) pole, facing  $\geq$  60 degrees apart, at the same height.
- Available extension bracket of a size indicated on the plan – 18" maximum.
- Wire entrance through the rear.
- Stainless steel mounting hardware.
- Color: The color shall be black No. 27038, Federal Standard No. 595.
- Finish: Housing/Frame and all mounting brackets either:
  1. Painted with 3 coats of infrared oven-baked paint before assembly.
    - Primer: Baked iron oxide which meets or exceeds FS TT-P-636.
    - Second coat: Exterior-baking enamel, light gray, which meets or exceeds FS TT-E-527.

- Third coat: Exterior-baking enamel, which meets or exceeds FS TT-E-489.
- 2. Electrostatic powder coated after chemically cleaned.
- Sign: CT DOT Sign No. 31-0845

**Construction Methods:**

Install the APS&D according to the manufacturer’s instructions. Position the ASP&D so the plane of the sign face is parallel to the crossing (sign is facing perpendicular) and the arrow is pointing in the same direction as the crossing, not necessarily at the ramp. Notify the Engineer if there is any discrepancy or ambiguity between the plans and field conditions that prevent placement of the ASP&D as shown on the plan. Set the minimum sound levels of the locator tone and the audible walk indication when there is little or no ambient noise as in night time operation. Set the volume of audible walk indications and pushbutton locator tones to a maximum of 5dBA louder than ambient sound. The locator tone should be audible 6’ to 12’ (1.8 m to 3.6 m) from the pushbutton or to the building line, whichever is less. Confirm the volume of both audible walk indication and the locator tone increases with an increase in ambient sound and subsequently decreases when the ambient noise decreases.

If programming method is remote, by an infrared hand-held device, provide one device and operation manual for each intersection where APS&D is installed.

**Method of Measurement:**

This work is measured by the number of APS&Ds of the type specified, installed, tested, fully operational, and accepted.

**Basis of Payment:**

Payment for this work is based on the installation, inspection, successful completion of the 30 day test period, and final acceptance of the Accessible Pedestrian Signal and Detector of the type specified. Payment includes the sign, mounting brackets for adjacent buttons on the same structure, extension brackets, all necessary cable, all incidental materials, labor, tools, and equipment necessary to complete the installation. Payment also includes the warrantee, installation manual, and operation manual.

If programming method is remote by an infrared hand-held device, the total bid price of all APS&Ds includes one remote programming device and accompanying operation manual for each intersection where APS&D is installed.

Pay Item	Pay Unit
Accessible Pedestrian Signal and Detector (Type A)	Each

## **ITEM #1108115A - FULL ACTUATED CONTROLLER 8 PHASE**

**Article 11.08.01 - Description:** Delete the second paragraph and replace with the following:

This item shall consist of furnishing and installing an actuated controller, which shall be a completely digital solid state unit, for controlling the operation of the traffic signals.

The controller shall be completely furnished with the number of phases called for in the item. The cabinet to house the controller shall be completely wired and all sub-bases shall be complete with load switches and flash relays as specified in the **Functional Specifications For Traffic Control Equipment**. The cabinet shall also have all necessary auxiliary equipment required to provide the sequence and timing indicated on the plans. A time switch shall be installed in each cabinet.

**Article 11.08.03 – Construction Methods:** Delete the entire second paragraph.

**Article M.16.09 - Controllers:** Add the following sub-articles:

2. Actuated Controllers: The purpose of this sub-article is to set forth minimum design and operating requirements for the materials and components for a digitally timed actuated controller.

Ventilation:

For cabinets that will be painted other than Department-approved gray, the cabinet ventilation shall include two intakes, exhausts, filtrations, two fans, and one thermostat assembly. Each electric fan shall be equipped with ball or roller bearings and with a capacity of at least 100 cfm. The fans shall be mounted inside the front top of the cabinet ventilation holes. The fans shall be controlled by one manually adjustable thermostat.

The Connecticut Department of Transportation Functional Specifications for Traffic Control Equipment, current edition governs the material for the Controller Assembly. The Functional Specifications are advertised biennial for vendors to provide equipment to the State on a low bid basis. All underlined text indicates an addition or revision to these specifications from the previous version. The Functional Specifications are available on the Departments website.

The following sections of the **Notice to Bidders**, pages 1 - 10, shall apply to contract supplied traffic controllers: 12, 15, 16, 17, 18, & 19.

Item 1108115A – FULL ACTUATED CONTROLLER 8 PHASE shall conform to the requirements of Section 1, pages 11 – 94. The Controller Unit (CU) shall conform to the requirements of Item 1D1, CONTROLLER (PRE-EMPTION TYPE), pages 29 – 31. All cabinets shall conform to the specifications of the “D” CABINET REQUIREMENTS, pages 78 – 84.

Controllers in a closed loop system shall conform to the requirements of Section 27, INTERNAL CLOSED LOOP SYSTEM FOR EXISTING NAZTEC SYSTEM, pages 162 – 185, in addition to the above requirements.

The solid state time switch shall conform to Section 13. FOUR CIRCUIT SOLID STATE TIME CLOCK WITH TIME BASE COORDINATION OPTION TC/TBC, pages 140 - 143.

Traffic signal equipment which has not been previously approved to meet the requirements of the Functional Specifications for the above items, will not be approved for use on this contract.

Several parts of Item 1 of the Functional Specifications do not apply to contract supplied and developer supplied traffic controllers. The specifications which are to be disregarded are listed below.

- Item 1A-1 - Controller, Two Phase Microprocessor Keyboard Entry  
- Type 6 Conflict Monitor
- Item 1A-2 - Two Phase Type "A" Cabinet

Supplemental specifications listed below, have been added for material and controller operations which the Department of Transportation does not include in the Functional Specifications for Traffic Control Equipment.

- U.C.F. Time Switch Flash Command Procedure
- Time Clock/Time Base Installation Requirements
- 24 Volt Relay                   Type A
- 110 Volt Relay                Type F
- Type G
- Time Delay Relay
- Non-Actuated Advance Green Phase
- Actuated Advance Green Phase
- Non-Actuated Clearance / Lag Green Phase
- Actuated Clearance / Lag Green Phase
- Flashing Stop Ahead Sign
- Max II Actuation By Pedestrian Call



## UNIFORM CODE FLASH COMMAND PROCEDURE

1. Activate the **MINIMUM RECALL** input to the controller to ensure cycling prior to transferring to flashing operation.
2. Omit all non-actuated and actuated artery advance phases.
3. Omit phases 1 & 5 of all quad sequences.
4. Activate the **STOP TIME** input to the controller, upon entering flash, to prevent cycling.
5. Transfer to flash at the end of the last side street all red condition (at the point the artery **ON** output becomes active).
6. Special technical notes on the intersection plan supercede the above requirements.

### TC/TBC INSTALLATION REQUIREMENTS

The following requirements are to be observed when engineering the installation of TC/TBC:

1.
  - a. Circuit 1 shall be designated FLASH and be reserved for night flash command.
  - b. Circuit 2 shall be designated MAX 2 and be reserved for Max 2 command.
  - c. Circuit 3 shall be designated COORD and shall select coordinated operation of the intersection.
  - d. Circuit 4 shall be the yield, and force off command to the controller.
2. All clock outputs shall be active to select the function specified. For example; If the TC/TBC were removed for repair, no inputs would be applied to the controller. The intersection will then operate non-coordinated, in Max 1. Programming the TC/TBC without cycle and offset is not an acceptable method to create a non-coordinated operation. Refer to the typical hookup diagram.
3. All TC/TBC clock installations shall be wired as detailed in figure 1. This method is used for both full and semi actuated operation.
4. Midnight resync shall occur at 12:00 AM.
5. A program card shall be completed indicating all input steps and settings. Four copies shall be provided. One copy left in the cabinet. Three delivered to the engineer along with the cabinet wiring diagrams.

### TIME CLOCK / TIME BASE COORDINATION

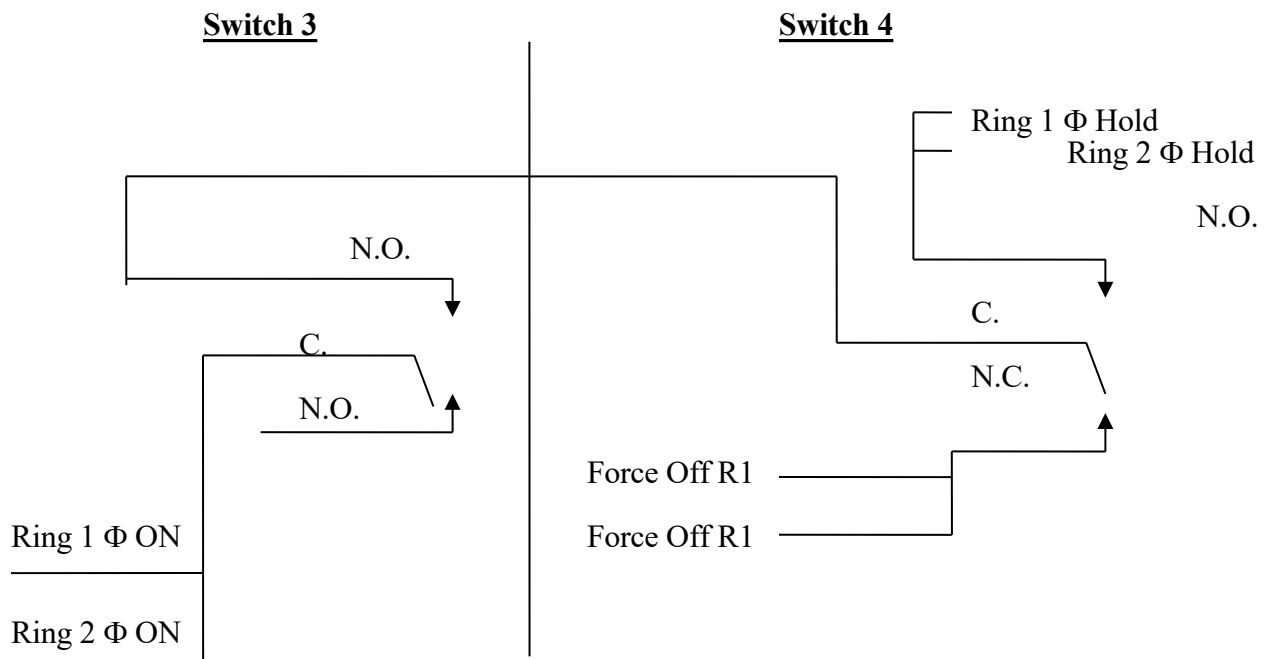

FIG. 1

## 24 VOLT RELAY

All 24 Volt relays shall meet the requirements of one of the following two types. Diodes shall be installed across the coils of all direct current relays to shunt the reverse voltage generated when the coil de-energizes. All diodes shall be general purpose ECG 125 1000prv @ 25A or equivalent, rated at least .5 amp forward biased. Diodes shall be external to the relay, not enclosed in the dust cover.

**TYPE A: Midland Ross, Midtex 155-92 or equivalent.**

### **DESCRIPTION:**

This relay shall be enclosed in a clear polycarbonate removable dust cover. It shall have a mechanical life of more than 100,000 operations at rated load.

### **CONTACTS:**

The contacts shall be 2 form C (D.P.D.T), U.L. rated at 5 amps 120 volts A.C. The contacts shall be pure fine silver (gold flash). There shall be no tungsten (lamp) load on the contacts of this relay.

**COIL:** The coil shall operate on 24 V.D.C. and have no less than 450 OHMS impedance.

**SIZE:** The relay shall be no larger than 65mm(2.5") H x 40mm(1.5") L x 40mm(1.5") W.

**BASE:** This relay shall have an eight pin octal plug-in base with the pin designation shown below:

1. Common (1)
2. Coil
3. Normally open (1)
4. Normally closed (1)
5. N.C. (2)
6. N.O. (2)
7. Coil (2)
8. Comm.

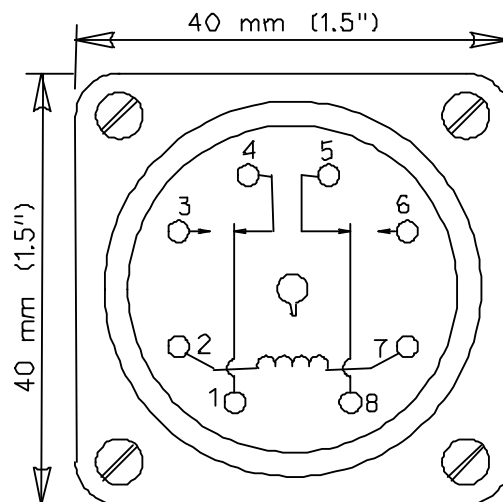

Bottom View And Wiring Diagram

**SOCKET:** The socket shall be a closed back, screw terminal type. The front mounted screws shall be 6-32 capable of accepting #14 AWG wire.

## 110 VOLT RELAY

All 110 volt relays shall meet the requirements of one of the following two types. Across the coil of each relay there shall be a molded suppressor rated at .1uf - 47 ohm @ 600V to suppress electrical noise created by the energization / de-energization of the relay.

**TYPE F:** Midland Ross, Midtex 136-62T3A1 or equivalent

**DESCRIPTION:**

Relays of this type shall function as flash transfer, power switching and signal drive. Other uses are acceptable, however, type G relays cannot be used for the above applications.

**CONTACTS:**

The contacts shall be in the D.P.D.T. form and consist of 10mm(3/8") diameter silver cadmium oxide, rated at 20 Amps @ 117 VAC resistive.

**COIL:**

The coil shall operate on 110 VAC. No semi-conductors will be allowed in the coil circuit of this relay.

**SIZE:**

The relay shall be enclosed in a clear plastic dust cover. The overall dimensions shall be no larger than 63mm(2 1/2") x 94mm(3 3/4") x 47mm(1 7/8") as illustrated below.

**BASE:**

This relay shall have an eight blade plug-in base, Ventron Beau Plug P-5408 or equivalent with the pin designations as shown below:

- 1. Coil
- 2. Coil
- 3. N.C. 1
- 4. N.C. 2
- 5. Comm. 1
- 6. Comm. 2
- 7. N.O. 1
- 8. N.O. 2

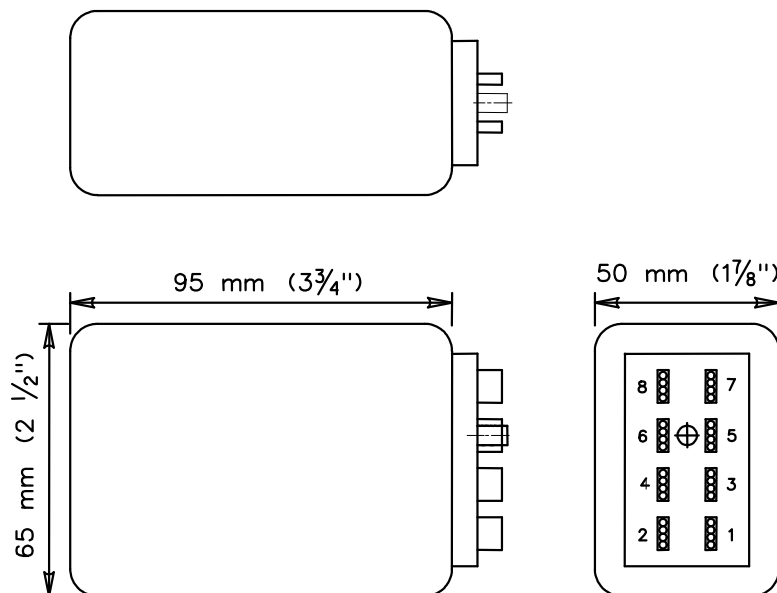

**SOCKET:**

The socket shall be Ventron Beau Plug S-5408 or equivalent, contacts rated at 15 Amps @ 1750 VRMS.

**TYPE G:** Magnecraft, W 88 ACXP-8 or equivalent

**DESCRIPTION:**

Relays of this type shall function in low current switching applications such as interconnect interface or pre-emption circuits. A clear polycarbonate plastic enclosure shall cover the relay mechanism.

**CONTACTS:**

The contacts shall be in the D.P.D.T. form and consist of 5mm (3/16") diameter gold flashed, silver alloy, rated at 10 Amps @ 120 VAC resistive.

**COIL:**

The coil shall operate on 120 Volts AC and require a nominal 3 VA.

**SIZE:**

Height, length and width dimensions shall be the same as the 24 volt relay Type A: 35mm (1 3/8") x 60mm (2 3/8") x 35mm (1 3/8").

**BASE:**

The base shall be an octal plug with the pin designations the same as the 24 volt relay Type A.

**SOCKET:**

The socket shall be the same as that for the 24 volt relay Type A.

### TIME DELAY RELAY

120 VAC      SSAC TDM120A or equivalent  
24 VDC      SSAC TDM24DL or equivalent

#### **DESCRIPTION:**

The time delay relays shall be self enclosed, plug-in, delay on operate type. They shall be digitally timed and adjustable by the use of dip switches located on the top of the case. The timing range shall be 1 to 1023 seconds in 1 second intervals. The time delay relays shall have an internal double pole double throw relay with form "C" contacts rated at 10 amps 120 volts AC. They shall operate accurately in a temperature range of -20 to +65 degrees C. A 120 volt AC input shall initiate timing of the 120 VAC TDR and a 24 VDC input shall initiate timing of the 24 VDC TDR. Removal of the input voltage shall reset the timer. Maximum dimensions of the case shall be as shown below.

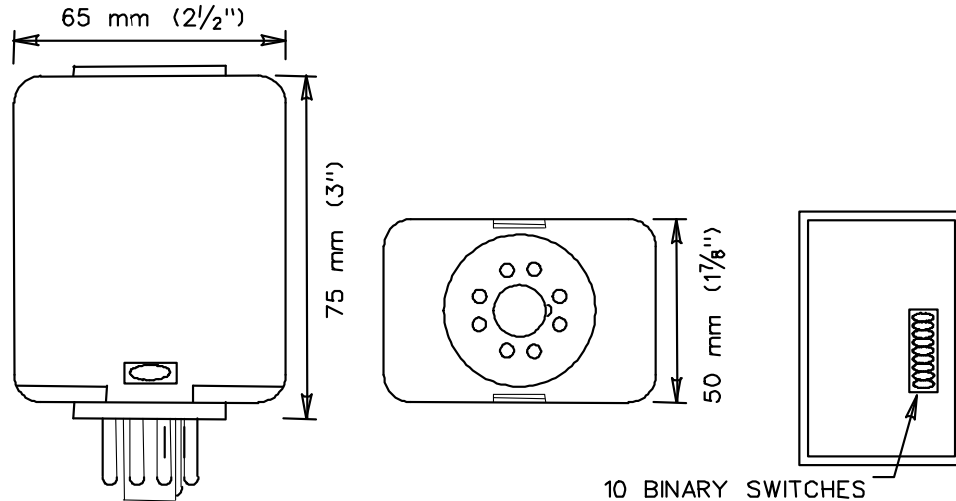

#### **SOCKET:**

The socket shall be a standard octal base (8 pin) with screw terminal connectors. The pin designation shall be as shown below.

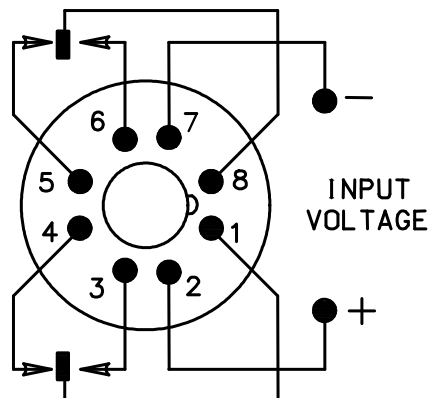

OCTAL (8 PIN) BASE

### NON-ACTUATED ADVANCE GREEN PHASE

Where the timing and sequence indicates an advance green phase that always precedes the phase in recall (usually phase 2), and that either is fixed timed or is to be extended only, the following guidelines shall be in effect:

1. The parent phase ON output shall be diode connected to the advance phase OMIT input.
2. If the advance phase is to be extendable, it shall be in minimum recall. If the advance phase is fixed timed, it shall be in maximum recall. A different advance time may be selected by switching to maximum 2.

Example: Phase 1 is the advance phase (extendable), in minimum recall.  
Phase 2 is the artery, in recall.  
Phase 4 is the minor street, in non-lock.

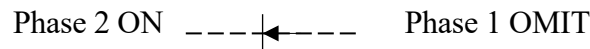

Where the timing and sequence indicates an advance phase that is fixed timed (not extendable), and that always precedes either a phase other than phase 2 or a phase not in recall, the following guidelines shall be in effect:

1. The recall phase (usually Phase 2) ON output shall be diode connected to the advance phase's, parent phase OMIT input.
2. The parent phase CHECK output shall be diode connected to the advance phase vehicle detector input.
3. The advance phase ON output shall be diode connected to the following parent phase vehicle detector input. This is to insure a green indication on the parent phase.
4. The advance phase shall be in the non-lock mode. The advance time shall be selected from the maximum interval.

Example: Phase 2 is the artery, in recall.  
Phase 3 is the advance for phase 4, in non-lock mode.  
Phase 4 (parent phase) is the minor street, in non-lock mode.

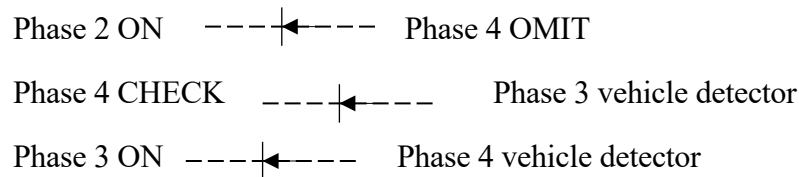

**ACTUATED ADVANCE GREEN**

Where the timing and sequence indicates an advance green phase that is to be extended only, and is to always precede either a phase other than phase 2 or a phase not in recall, the following guidelines shall be in effect:

1. The phase ON outputs of all phases that could precede the advance phase, shall be diode connected to the parent phase OMIT input.
2. The parent phase CHECK output shall be diode connected, through the normally closed contacts of a relay, to the advance phase vehicle detector input. The advance phase loop detector output shall be connected to the normally open contacts.
3. The relay coil shall be energized by the advance phase ON output, which in turn will switch the vehicle detector input from the parent phase CHECK circuit to the loop detector.
4. The advance phase ON output shall be diode connected to the following parent phase vehicle detector input. This is to insure a green indication from the parent phase.
5. The advance phase shall be in the non-lock mode.

Example: Phase 2 is the artery, in recall.  
Phase 3 is the pedestrian phase.  
Phase 4 is the advance for phase 5, in non-lock.  
Phase 5 (parent phase) is the minor street, in non-lock.

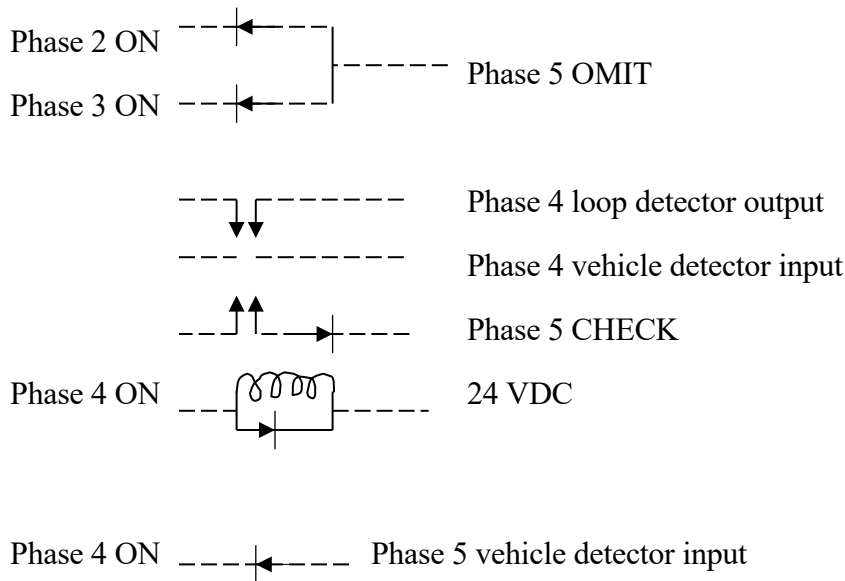

The 24 volt relay shall be Type C as previously described in these specifications.



**NON-ACTUATED CLEARANCE PHASE**

**NON-ACTUATED LAG GREEN PHASE**

Where the timing and sequence indicates a non-actuated clearance phase or a lagging green phase that always follows the phase in recall, the following guidelines shall be in effect:

1. The parent phase ON output shall be diode connected to all appropriate phase OMIT inputs except the clearance phase.
2. The remaining actuated phases shall have their CHECK outputs diode connected to the clearance phase vehicle detector input.
3. The clearance phase ON output shall be diode connected to the following phases vehicle detector input (if the phase is in non-lock mode). This will prevent the controller from returning to the parent phase from the clearance phase without servicing the minor street.
4. The clearance phase shall be in the non-lock mode.
5. The clearance, or lag green time shall be selected from the maximum interval.

Example: Phase 2 is the artery, in recall.  
Phase 3 is the clearance phase, in non-lock.  
Phase 4 is the pedestrian phase.  
Phase 5 is the minor street, in non-lock.

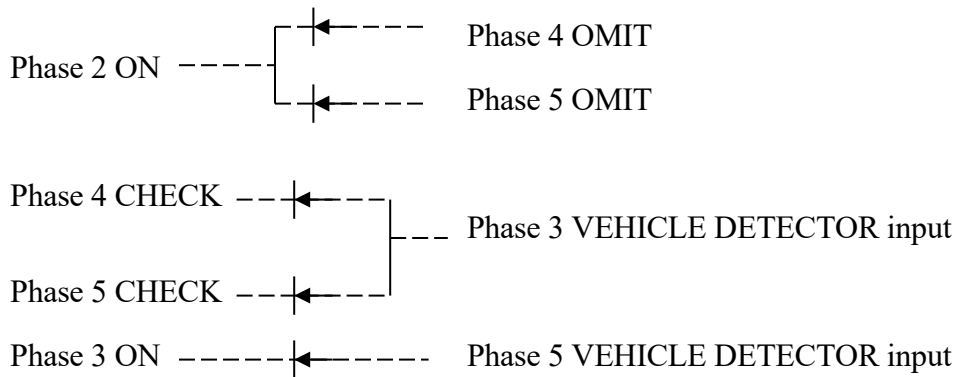

Where the timing and sequence shows a non-actuated clearance phase or lagging green phase following either a phase other than phase 2 or a phase not in recall, the following guidelines shall be in effect:

1. The parent phase ON output shall be diode connected to the following clearance phase vehicle detector input. This insures the clearance phase will always follow the parent phase.
2. The clearance phase shall be in the non-lock mode.
3. The clearance, or lag green time shall be selected from the minimum green interval.



**ACTUATED CLEARANCE PHASE**

**ACTUATED LAG GREEN PHASE**

Where the timing and sequence indicates an actuated lagging green phase that is to be extended only, and always follows another phase, the following guidelines shall be in effect:

1. The parent phase (usually phase 2) ON output shall be diode connected to the phase OMIT inputs of all phases that could follow the lag phase.
2. The CHECK outputs of all phases that could follow the lag phase shall be diode connected, through the normally closed contacts of a relay, to the lag phase vehicle detector input. The lag phase loop detector output shall be connected to the normally open contacts.
3. The relay coil shall be energized by the lag phase ON output which in turn will switch the phase detector input from the CHECK circuits to the loop detector.
4. The lag phase shall be in the non-lock mode.

Example: Phase 2 (parent phase) is the artery, in recall.  
Phase 3 is the lag phase, in non-lock.  
Phase 4 is the pedestrian phase.  
Phase 5 is the minor street, in non-lock.

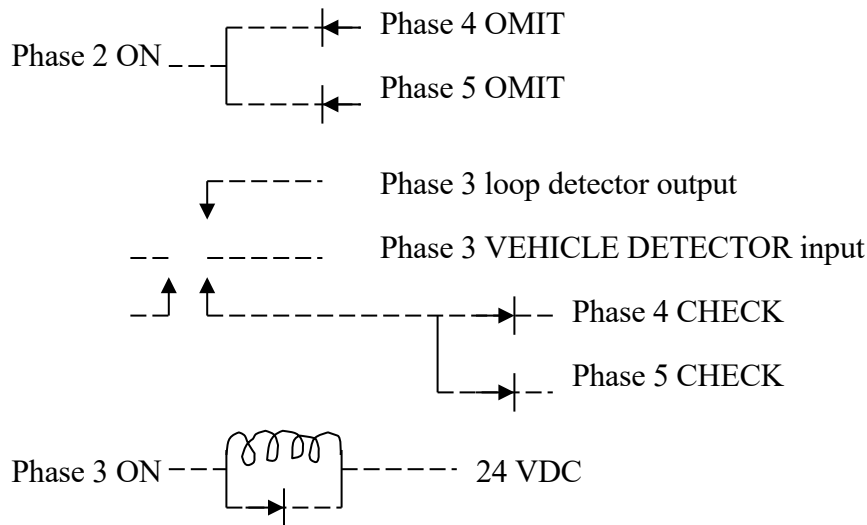

The 24 VDC relay shall be Type C as previously described in these specifications.

**FLASHING STOP AHEAD SIGN**

Where the timing and sequence indicates a flashing stop ahead sign, the clearance interval following the phase that the sign is off shall be timed by the following method.

The following phase shall be used for the clearance time. These phases shall be overlapped. The green indication will be maintained by the overlap feature and the following phase green time will be the stop ahead sign clearance.

The artery phase ON output shall be diode connected to all other phase OMIT inputs except the clearance phase and the artery phase. The CHECK outputs from the remaining phases (as needed) shall be diode connected to the sign clearance phase vehicle detector input. The clearance phase shall be in the non-lock mode.

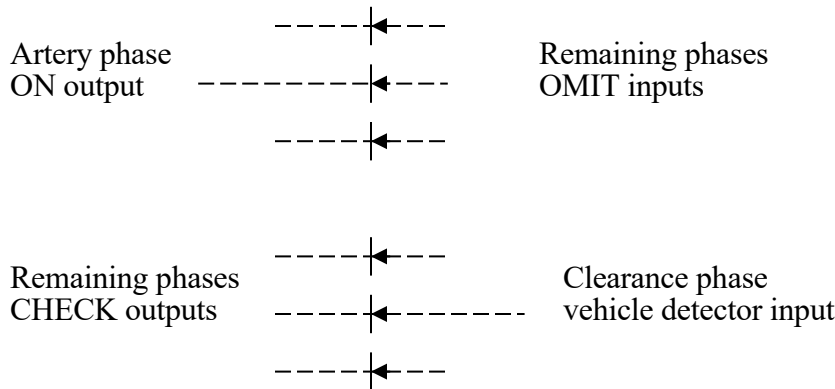

If the non-artery phases are in the non-lock mode, a call must be forced to the non-artery phase once the controller leaves the artery Hold interval (either artery walk or artery green). This prevents a false "Stop Ahead" indication if a vehicle turns right on red during the flashing sign clearance interval.

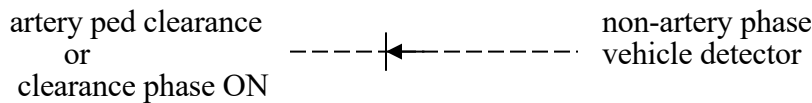

Unless otherwise shown on the plans, the 110 VAC flash power shall be from a spare load switch in the controller cabinet. The load switch input shall be driven with the flashing logic output from the controller. The flashing logic output shall be disconnected from the load switch during the intervals the sign is inactive.

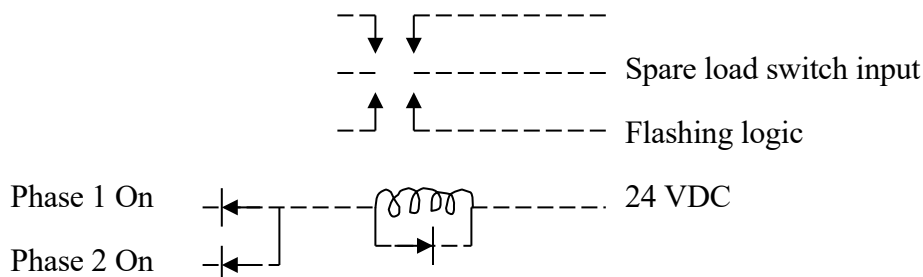

Typical drive circuit for "WHEN FLASHING STOP AHEAD" sign

### TIME BASE COORDINATION MAX II ACTUATION BY PEDESTRIAN CALL

When the sum of the split times, including the walk and don't walk, exceed the background cycle length, the designer may choose to either allow a double cycle of the background timer or reduce the phase timings when the ped phase is called. Reduction of the phase timing by switching to MAX 2 avoids double cycling.

Where indicated on the plans the exclusive pedestrian phase will call MAX II. The minor movement max 2 times are set low so that the total phase times do not exceed the coordination cycle length.

Install a 24 volt relay connected to the inputs and outputs as shown on the following schematic.

Operation: When the controller advances to the exclusive pedestrian phase, the relay is actuated and latched. MAX II timing is selected for one complete cycle, until the relay is unlatched by the artery yellow (absence of red or green).

Example: Phase 2 is the artery. Phase 3 is the exclusive pedestrian phase.

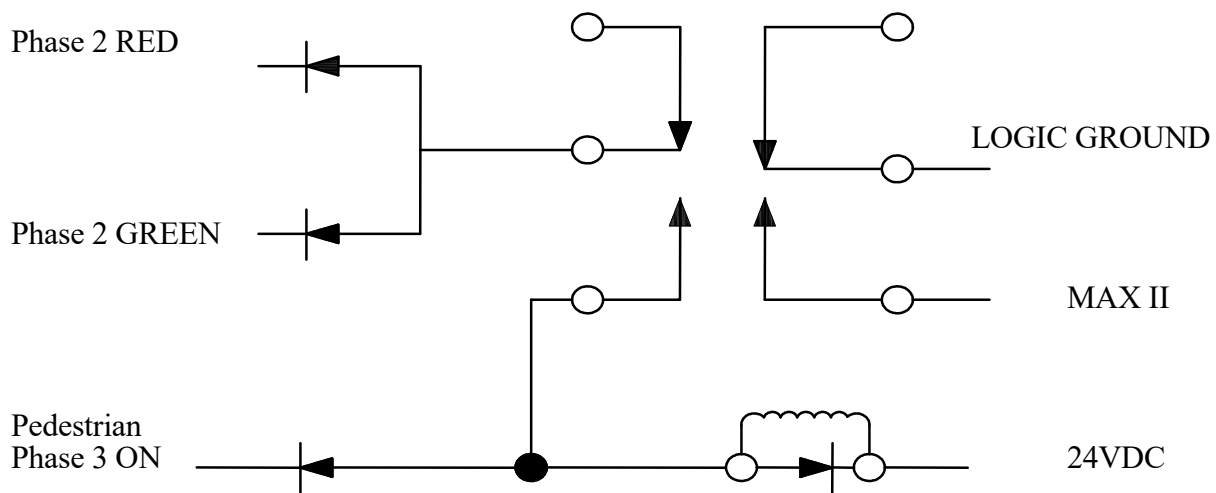

**ITEM #1108724A - PHASE SELECTOR**

**ITEM #1112410A - DETECTOR (TYPE A)**

**ITEM #1112470A - PRE-EMPTION SYSTEM CHASSIS**

**ITEM #1113550A - DETECTOR CABLE (OPTICAL)**

**SYSTEM DESCRIPTION:**

The emergency vehicle traffic signal priority control system shall enable designated vehicles to remotely cause the traffic signal controller to advance to and/or hold a desired traffic signal display by using existing controller functions. The control shall be activated at a minimum distance of 1,800 feet (548.6m) along an unobstructed "line of sight" path. The control shall not terminate until the vehicle is within 40 feet (12.2m) of the detector or at the intersection.

The system shall consist of the following components:

- A. Phase Selector (minimum 2 channel) which shall cause the signal controller to advance to and/or hold the desired traffic signal display for the emergency vehicle. A pre-emption system chassis shall house two phase selectors.
- B. Optical Detector which shall be mounted on or near a traffic signal and shall receive the optical energy signals generated by the Vehicle Emitter.

Detector (Type A), 1 Direction, 1 Channel

- C. Detector Cable (Optical).

**System Operation:**

- A. The operating sequence shall be initiated when the optical detector receives the required optical energy signal from the Emitter.
- B. The phase selector shall cause the traffic signal controller to advance to and/or hold the desired traffic signal display for the emergency vehicle.
- C. The phase selector shall cause the controller to advance to and/or hold the desired traffic signal display even if the optical energy signals cease before the desired display is obtained.
- D. The phase selector shall allow the traffic signal controller to resume normal operation within ten seconds after optical energy signals cease if the optical energy signals cease after the desired traffic signal display is obtained.

- E. The phase selector shall not respond to optical energy signals from an emergency vehicle if it is already processing optical energy signals from another emergency vehicle.

### **System Components:**

#### A. Optical Detector:

The optical detector receives the high intensity optical pulses produced by the emitter. These optical energy pulses are transformed by the detector into appropriate electrical signals which are transmitted to the phase selector. The optical detector is mounted at or near the intersection in a location which permits an unobstructed line of sight to vehicular approaches. The units may be mounted on signal span wires, mast arms or other appropriate structures.

1. Shall be of solid state construction.
2. Shall operate over an ambient temperature range of minus 30<sup>o</sup> F. to plus 165<sup>o</sup> F. (minus 34<sup>o</sup> C to plus 74<sup>o</sup> C)
3. Shall have internal circuitry potted in a semi-flexible compound to ensure moisture resistance.
4. Shall operate in 5 to 95 % humidity.
5. Shall have a cone of detection of not more than 13 degrees. The detector and/or phase selector shall not sense a pre-emption signal from an emitter outside this cone.

#### B. Phase Selector:

The phase selector supplies power to and receives electrical signals from the optical detector. When detector signals are recognized as a valid call, the phase selector causes the signal controller to advance to and/or hold the desired traffic signal display. This is accomplished by activating the pre-empt input to the controller.

The phase selector is capable of assigning priority traffic movement to one of two channels on a first-come, first-serve basis. Each channel is connected to select a particular traffic movement from those normally available within the controller. Once a call is recognized, "commit to green" circuitry in the phase selector functions so that the desired green indication will be obtained even if optical communication is lost. After serving a priority traffic demand, the phase selector will release the controller to follow normal sequence operation.

1. Shall include an internal power supply to supply power to the optical detectors.
2. Shall have minimum two-channel operation with the capability of interfacing with an additional phase selector for expansion of channels of operation.
3. Shall have adjustable detector range controls for each channel of operation, from 40 feet (12m) to 1800 feet (548m).

4. Shall have solid state indicator lights for power on and channel called.
5. Shall operate over an ambient temperature range of minus 30<sup>o</sup> F. to plus 165<sup>o</sup> F.  
(minus 34<sup>o</sup> C to plus 74<sup>o</sup> C)
6. Shall operate in 5 to 95 % humidity.

C. Pre -Emption System Chassis:

1. Card cage/slot shall provide all the necessary hardware and harnessing required to allow simple wiring of phase selector to detector outputs and controller inputs..
2. Shall have harness to carry 115VAC and card outputs.
3. Shall include terminal block/strip for connecting the detectors.

D. Detector Cable (Optical):

1. 3-Conductor cable with shield and ground wire.
2. AWG #20 (7x28) stranded.
3. Individually tinned copper strands.
4. Conductor insulation: 600 volt, 167<sup>o</sup> F. (75 deg. C).
5. 1 Conductor-yellow; 1 Conductor-blue; 1 Conductor-orange.
6. Aluminized mylar shield tape or equivalent.
7. AWG #20 (7x28) stranded uninsulated drain wire
8. DC resistance not to exceed 11.0 ohms per 1000 feet (305m).
9. Capacitance from one conductor to other two conductors and shield not to exceed 48 pf/ft. (157pf/m).
10. Jacket: 600 volts, 176<sup>o</sup> F. (80 deg. C), minimum average wall thickness – 0.045” (1.14mm).
11. Finished O.D.: 0.3” (7.62mm) max.

**System Interface:**

System shall be capable of operating in a computerized traffic management system when appropriate interfacing is provided by the computer supplier.

**General:**

The Contractor shall furnish the manufacturer the phasing diagrams indicating controller sequence and timing.

The Contractor shall secure from the manufacturer a guarantee for the equipment for a period of sixty (60) months, which time shall commence from the date of delivery. Manufacturer shall certify upon request that all materials furnished will conform to this specification. The manufacturer or his designated representative shall be responsible for determining and setting all required range and emitter intensity for the emergency vehicle operation.

## **Construction Methods:**

All equipment except the vehicle emitter assembly shall be installed and wired in a neat and orderly manner in conformance with the manufacturers' instructions. Installation of the vehicle emitter assembly shall be the responsibility of the town.

Traffic signals owned and maintained by the State that have optical pre-emption equipment owned and maintained by the town shall have an Auxiliary Equipment Cabinet (AEC) attached to the controller cabinet. The optical pre-emption equipment shall be housed in the AEC. Traffic signals owned and maintained by the town do not require an AEC to house the pre-emption equipment.

Detector cables shall be continuous with no splices between the optical detector and the AEC.

Detector locations shown on the plan are for illustration purposes only. Exact location shall be determined by the contractor or the designated representative for the best possible line of sight.

If not present in an existing traffic controller cabinet, the following items shall be installed and connected, in conformance with the current Functional Specifications for Traffic Control Equipment, "D" Cabinet Requirements (Pre-emption Type):

- Controller "D" harness and adapter.
- Pre-emption termination panel with terminal block and relay bases.
- Pre-emption disconnect switch, mounted on the emergency switch panel (on inside of cabinet door).
- Pre-emption test buttons, mounted on the pre-emption termination panel.

All connections from the phase selector to the "D" harness and to the cabinet wiring shall be made at the termination panel. The termination panel shall have AC+ Lights, AC-, and a switched logic ground. The switched logic ground feeds all the pre-empt inputs to the phase selector. When switched off by the pre-emption disconnect switch, the traffic controller shall not be affected by pre-empt calls from the optical pre-emption system. A minimum of two test buttons shall be provided. If there are more than two pre-empt runs, a button for each shall be installed. A chart or print out indicating the program steps and settings shall be provided along with the revised cabinet wiring diagrams.

## **Test the Pre-emption System at the semi-final inspection According to the following Guidelines:**

1. Notify the system owner/user, such as the municipal fire chief or public works director, of the scheduled inspection
2. Request a fire department representative and an emergency vehicle, which has an emitter to conduct the test. If not available, the contractor shall provide an emitter.
3. In the presence of the Engineer and the municipal representative, test each pre-empted approach with the emergency vehicle. Test the following items of the system:
  - \* Confirm that the emitter activates the phase selector and the phase selector activates the correct pre-emption input to the controller.



- \* Confirm adequate range. The traffic signal must be pre-empted to green sufficiently in advance of the emergency vehicle arrival. The vehicle emitter shall initiate pre-emption at a minimum distance of 1800 FT. (548.6m).
  - \* Confirm there are no false calls. Keep the emitter active as the emergency vehicle passes through the intersection. No other optical detectors shall sense the strobe.
4. Document the test. Provide the Engineer and, upon request, the municipality copies of the test results.

If a malfunction is found or the system needs adjustment (such as range, emitter intensity, or detector location), schedule a follow-up test. Repeat the above steps for all approaches that did not pass.

All adjustments such as emitter intensity, phase selector range, sensitivity, detector placement, shall be made at the intersection by the contractor so that the optical pre-emption operates correctly with other major manufacturers' equipment currently owned by the town.

**Method of Measurement:**

Optical Detectors, Phase Selectors, System Chassis will be measured for payment by the number of each supplied, installed and accepted. Detector Cable (Optical) will be measured by the number of linear feet (meters) supplied, installed and accepted.

**Basis of Payment:**

Payment for Optical Detectors, Phase Selector, System Chassis and Detector Cable (Optical) will include the item unit cost, including all manufacturer's required mounting hardware and the cost of installation and supervision by the manufacturer or his designated representative, including travel and subsistence, and all materials, equipment and labor incidental thereto. Payment for termination panel, "D" harness, test buttons, program chart (or print out) and revised cabinet wiring diagrams shall be included in the item PRE-EMPTION SYSTEM CHASSIS.

<u>Pay Items</u>	<u>Pay Units</u>
Detector (TYPE A)	Ea.
Phase Selector	Ea.
Detector Cable (Optical)	L.F. (m)
Pre-Emption System Chassis	Ea.

## **ITEM NO. 1111201A – TEMPORARY DETECTION (SITE NO. 1)**

### **Description:**

Provide a Temporary Detection (TD) system at signalized intersections throughout the duration of construction, as noted on the contract plans or directed by the Engineer. TD is intended to provide an efficient traffic-responsive operation which will reduce unused time for motorists travelling through the intersection. A TD system shall consist of all material, such as pedestrian pushbutton, accessible pedestrian signal, conduit, handholes, cable, messenger, sawcut, loop amplifier, microwave detector, Video Image Detection System (VIDS), Self-Powered Vehicle Detector (SPVD), and any additional components needed to achieve an actuated traffic signal operation.

### **Materials:**

Material used for TD is either owned by the Contractor and in good working condition, or existing material that will be removed upon completion of the contract. Approval by the Engineer is needed prior to using existing material that will be incorporated into the permanent installation. New material that will become part of the permanent installation is not included or paid for under TD.

### **Construction Methods:**

The work for this item includes furnishing, installation, relocating, realigning, and maintaining the necessary detection systems as to provide vehicle and pedestrian detection during each phase of construction. If not shown on the plan, program the TD modes (pulse or presence) as the existing detectors or as directed by the Engineer. If the TD method (loops, SPVD, microwave, VIDS, pushbutton, or other) it may be the Contractor's choice. The method chosen for TD must be indicated on the TD Plan submission.

The traffic signal plan-of-record, if not in the controller cabinet will be provided upon request. Ensure the controller phase mode (recall, lock, non-lock) and phase timing are correct for the TD. Adjust these settings as needed or as directed by the Engineer.

At least 30 days prior to implementation of each phase of construction submit a TD proposal to the Engineer for approval. Submit the TD proposal at the same time as the Temporary Signalization plan. Indicate the following information for each intersection approach:

- Phase Mode
- Temporary Detection Method
- Area of Detection
- Detector Mode

Submit the proposed temporary phase timing settings and the TD installation schedule with the TD proposal. See the example below.

Example Proposed Temporary Detection and Timing

**Site 1**

Warren, Rt. 45 at Rt. 341, Location #149-201

Approach	Phase	Phase Mode	TD Method	Area of Detection	Det Mode
<i>Rt. 45 NB</i>	<i>2</i>	<i>Min Recall</i>	<i>VIDS</i>	<i>150' from Stop Bar</i>	<i>Pulse</i>
<i>Rt. 45 SB</i>	<i>2</i>	<i>Min Recall</i>	<i>SPVD</i>	<i>150' from Stop Bar</i>	<i>Pulse</i>
<i>Rt. 341</i>	<i>4</i>	<i>Lock</i>	<i>Microwave</i>	<i>30' from Stop Bar</i>	<i>Pulse</i>
<i>Rt. 341</i>	<i>4</i>	<i>Lock</i>	<i>Pushbutton</i>	<i>At SE &amp; SW corners</i>	<i>n/a</i>

Temporary Phase Timing Settings:

Phase	Min	Ped	Ped Clr	Ext	Max 1	Max2	Yel	Red
<i>2</i>	<i>20</i>	<i>0</i>	<i>0</i>	<i>6</i>	<i>45</i>	<i>60</i>	<i>4</i>	<i>1</i>
<i>4</i>	<i>14</i>	<i>7</i>	<i>9</i>	<i>3</i>	<i>27</i>	<i>35</i>	<i>3</i>	<i>1</i>

Scheduled TD: *July 4, 2011* **Site 2**

Scotland, Rt. 14 at Rt. 97, Location #123-201

Approach	Phase	Phase Mode	TD Method	Area of Detection	Det Mode
<i>Rt. 15 WB Left Turn</i>	<i>1</i>	<i>Non-Lock</i>	<i>VIDS</i>	<i>5' in front to 10' Behind Stop Bar</i>	<i>Presence</i>
<i>Rt. 14 EB</i>	<i>2</i>	<i>Min Recall</i>	<i>Existing Loop</i>	<i>150' from Stop Bar</i>	<i>Pulse</i>
<i>Ped Phase</i>	<i>3</i>	<i>Non-Lock</i>	<i>Pushbutton</i>	<i>At all corners</i>	<i>n/a</i>
<i>Rt. 14 WB</i>	<i>6</i>	<i>Min Recall</i>	<i>VIDS</i>	<i>150' from Stop Bar</i>	<i>Pulse</i>
<i>Rt. 97</i>	<i>4</i>	<i>Lock</i>	<i>Loop, Pre-formed</i>	<i>20' from Stop Bar</i>	<i>Pulse</i>

Temporary Phase Timing Settings:

Phase	Min	Ped	Ped Clr	Ext	Max 1	Max2	Yel	Red
<i>1</i>	<i>5</i>	<i>0</i>	<i>0</i>	<i>2</i>	<i>12</i>	<i>18</i>	<i>3</i>	<i>0</i>
<i>2 &amp; 6</i>	<i>24</i>	<i>0</i>	<i>4</i>	<i>4</i>	<i>26</i>	<i>36</i>	<i>4</i>	<i>1</i>
<i>3</i>	<i>16</i>	<i>7</i>	<i>9</i>	<i>0</i>	<i>16</i>	<i>16</i>	<i>4</i>	<i>1</i>
<i>4</i>	<i>14</i>	<i>7</i>	<i>9</i>	<i>3</i>	<i>27</i>	<i>35</i>	<i>3</i>	<i>1</i>

Scheduled TD: *July 4, 2011*

When at any time during construction the existing vehicle or pushbutton detection becomes damaged, removed, or disconnected, install TD to actuate the affected approaches. Install and make TD operational prior to removing existing detection. TD must be operational throughout all construction phases.

Provide a list of telephone numbers of personnel who will be responsible for the TD to the Engineer. If the TD malfunctions or is damaged, notify the Engineer and place the associated phase on max recall. Respond to TD malfunctions by having a qualified representative at the site within three (3) hours. Restore detection to the condition prior to the malfunction within twenty-four (24) hours.

If the Engineer determines that the nature of a malfunction requires immediate attention and the Contractor does not respond within three (3) hours following the initial contact, then an alternative maintenance service will be called to restore TD. Expenses incurred by the State for alternative service will be deducted from monies due to the Contractor with a minimum deduction of \$500.00 for each service call. The alternate maintenance service may be the traffic signal owner or another qualified Contractor.

TD shall be terminated when the detection is no longer required. This may be either when the temporary signal is taken out of service or when the permanent detectors are in place and fully operational.

Any material and equipment supplied by the Contractor specifically for TD shall remain the Contractor's property. Existing material not designated as scrap or salvage shall become the property of the Contractor. Return and deliver to the owner all existing equipment used as TD that is removed and designated as salvage.

**Method of Measurement:**

Temporary Detection will be paid only once per site as a percentage of the contract Lump Sum price. Fifty percent (50%) will be paid when Temporary Detection is initially set up, approved, and becomes fully operational, and fifty percent (50%) will be paid when Temporary Detection terminates and all temporary equipment is removed to the satisfaction of the Engineer.

**Basis of Payment:**

This work will be paid at the contract Lump Sum price for "Temporary Detection (Site No.)". The price includes furnishing, installing, relocating, realigning, maintaining, and removing, the necessary detection systems and all incidental material, labor, tools, and equipment. This price also includes any detector mode setting changes, timing or program modifications to the controller

that are associated with TD. All Contractor supplied material that will remain the Contractor's property will be included in the contract Lump Sum price for "Temporary Detection (Site No.)." Any items installed for TD that will become part of the permanent installation will not be paid for under this item but are paid for under the bid item for that work.

<u>Pay Item</u>	<u>Pay Unit</u>
Temporary Detection (Site No.)	L. S.

## **ITEM #1111401A - LOOP VEHICLE DETECTOR**

## **ITEM #1111451A - LOOP DETECTOR SAWCUT**

Replace Section 11.11, LOOP VEHICLE DETECTOR AND SAWCUT, with the following:

### **11.11.01 – Description:**

1. Furnish and install a loop vehicle detector amplifier.
2. Sawcut pavement. Furnish and install loop detector wire in sawcut.

### **11.11.02 – Materials:**

Article M.16.12

## **M.16.12 - LOOP VEHICLE DETECTOR AND SAWCUT**

### **1. Loop Vehicle Detector:**

- Comply with National Electrical Manufacturers Association (NEMA) standards, Section 6.5, Inductive Loop Detectors.
- Comply with the current CT DOT Functional Specifications for Traffic Control Equipment, Section 3 B, Loop Vehicle Detector with Delay/Extend Option.

### **2. Sawcut:**

#### **(a) Wire in sawcut:**

- International Municipal Signal Association (IMSA) Specification 51-7, single conductor cross-linked polyethylene insulation inside polyethylene tube.
- # 14 AWG

#### **(b) Sealant:**

##### **(1) Polyester Resin Compound**

- Two part polyester which to cure, requires a liquid hardener.
- Use of a respirator not necessary when applied in an open air environment.
- Cure time dependent on amount of hardener mixed.
- Flow characteristics to guarantee encapsulation of loop wires.
- Viscosity: 4000 CPS to 7000 CPS at 77 degrees Fahrenheit (25° C).
- Form a tack-free skin within 25 minutes and full-cure within 60 minutes at 77 degrees Fahrenheit (25° C).
- When cured, resist effects of weather, vehicular abrasion, motor oil, gasoline, antifreeze, brake fluid, de-icing chemicals, salt, acid, hydrocarbons, and normal roadway encounters.
- When cured, maintain physical characteristics throughout the ambient temperature ranges experienced within the State of Connecticut.
- When cured, bonds (adheres) to all types of road surfaces.
- Weight per Gallon (3.8 l): 11 lbs ±1 lb (5kg ± .45kg)

- Show no visible signs of shrinkage after curing.
- 12 month shelf life of unopened containers when stored under manufacturers specified conditions.
- Cured testing requirements:
  - Gel time at 77 degrees F (25° C): 15 - 20 minutes, ASTM C881, D-2471
  - Shore D Hardness at 24 hours: 55-78, ASTM D-2240
  - Tensile Strength: > 1000 psi (6895 kPa), ASTM D-638
  - Elongation: 18 - 20 %, ASTM D-638
  - Adhesion to steel: 700 - 900 psi (4826 - 6205 kPa), ASTM D-3163
  - Absorption of water, sodium chloride, oil, and gasoline: < 0.2%, ASTM D-570
- Include in the Certificate of Compliance:
  - Manufacturer's confirmation of the uncured and cured physical properties stated above.
  - Material Safety Data Sheet (MSDS) stating sealant may be applied without a respirator in an open air environment.
- Designed to allow clean-up without the use of solvent that is harmful to the workers and the environment.

(2) Elastomeric Urethane Compound:

- One part urethane which to cure, does not require a reactor initiator, or a source of thermal energy prior to or during its installation.
- Use of a respirator not necessary when applied in an open air environment.
- Cure only in the presence of moisture.
- Flow characteristics to guarantee encapsulation of loop wires.
- Viscosity such that it does not run out of the sawcut in sloped pavement during installation; 5000 CPS to 85,000 CPS.
- Form a tack-free skin within 24 hours and 0.125 inch (0.33mm) cure within 30 hours at 75 degrees Fahrenheit (24° C).
- When cured, resist effects of weather, vehicular abrasion, motor oil, gasoline, antifreeze, brake fluid, de-icing chemicals, salt, acid, hydrocarbons, and normal roadway encounters.
- When cured, maintain physical characteristics throughout the ambient temperature ranges experienced within the State of Connecticut.
- Show no visible signs of shrinkage after curing.
- Shelf life when stored under manufacturers specified conditions:
  - Caulk type cartridges: minimum 9 months
  - Five gallon containers: minimum 12 months
- Designed for application when the pavement surface temperature is between 40 and 100 degrees Fahrenheit (4° and 38° C).
- Uncured testing requirements:
  - Weight/Gallon: ASTM D-1875
  - Determination of Non-volatile Content: ASTM D-2834
  - Viscosity: ASTM D-1048B
  - Tack-free Time: ASTM D-1640
- Cured testing requirements:
  - Hardness: ASTM D-2240
  - Tensile Strength & Elongation: ASTM D-412A
- Include in the Certificate of Compliance:
  - Manufacturer's confirmation of the uncured and cured physical properties stated above.
  - Material Safety Data Sheet (MSDS) stating sealant may be applied without a respirator in an open air environment.

- Designed to allow clean-up without the use of solvent that is harmful to the workers and the environment.

### 3. Miscellaneous:

- (a) Liquidtight Flexible Nonmetallic Conduit
  - UL listed for direct burial
  - UL 1660
  - Smooth polyvinyl chloride inner surface
- (b) Water Resistant Pressure Type Wire Connector
  - UL listed for direct burial and wet locations
  - UL 486D

### 11.11.03 - Construction methods:

#### 1. Loop Vehicle Detector

- Shelf-mount the detector amplifier in the controller cabinet.
- Terminate the harness conductors with crimped spade connectors. Connect conductors to appropriate terminals, eg, black wire to 110vac, white wire to 110vac neutral.
- Tie loop harness and conductors to controller cabinet wiring harness. Leave enough slack in loop harness so that amplifier may be moved around on cabinet shelf;  $\pm 2$  feet (0.6 meter) slack.
- Attach a loop identification tag to the harness. Record pertinent detector information on the tag with indelible ink. See example below.
  - Loop No.: *D4*
  - Phase Call: *Phase 4*
  - Field Location: *Rt. 411(West St.)*
  - *Eastbound, Left Lane*
  - Detector No.: *4*
  - Cabinet Terminals: *234, 235*

#### 2. Loop Detector Sawcut

- Loop size, number of turns, and location is shown on the intersection plan.
- Do not cut through a patched trench, damaged or poor quality pavement without the approval of the Engineer.
- Wet-cut pavement with a power saw using a diamond blade  $\frac{3}{8}$  inch (9.5mm) wide. Dry-cut is not allowed.
- Ensure slot depth is between 1  $\frac{3}{4}$  inch to 2.0 inch (45mm to 50mm).
- Overlap corners to ensure full depth of cut.
- To prevent wire kinking and insulation damage, chamfer inside of corners that are  $\leq 120$  degrees.
- Clean all cutting residue and moisture from slot with oil-free compressed air. Ensure slot is dry before inserting wire and sealing sawcut.
- Cut home-run, from loop to curb or edge-of-road, as shown on the typical installation sheet.
- To prevent cross-talk and minimize electrical interference, twist home-run wires, from edge of road to handhole, with at least 5 turns per foot (16 turns per meter). Tape together twisted home-run wires at 2 foot (0.6 meter)  $\pm$  intervals.
- In new or resurfaced pavement, install loops in the wearing course. If the wearing course is not scheduled for immediate placement (within 24 hours) after the base course, provide temporary detection when directed by the Engineer. Temporary detection may be sawcut



loops, preformed loops, microwave sensor, video, or other method approved by the Engineer.

- Splice(s) not allowed anywhere in loop wire either in loop or in home-run.
- Ensure wires are held in place at bottom of slot by inserting at 2 foot (0.6 m) intervals, 1 inch sections of foam backer rod or wedges formed from 1 inch (25mm) sections of the polyethylene tubing. Loop detectors with wires that have floated to the top of the sealant will not be accepted.
- To create a uniform magnetic field in the detection zone, wind adjacent loops in opposite directions.
- Use **polyester compound** as the sealant unless another type is allowed by the Engineer.
- Mix hardening agent into polyester resin with a power mixer or in an application machine designed for this type of sealant in accordance with the manufacturer's instructions.
- Apply the loop sealant in accordance with the manufacturer's instructions and the typical installation sheet. Do not apply sealant when pavement temperature is outside the manufacturer's recommended application range.
- Solder splice the loop wires to the lead-in cable and install water resistant connector as shown on the typical installation sheet.
- Test the loop circuit resistance, inductance, and amplifier power-interruption as shown on the typical installation sheet. Document all test results.

### 3. Damaged, Patched, or Excessively Worn Pavement

- Where the existing pavement is damaged, patched or excessively worn and is found to be not suitable for reliable loop detection, notify the Engineer.
- When directed by the Engineer, remove and replace an area of pavement to allow the proper installation of the loop.
- Remove a minimum of 3 inches (75mm) depth.
- Comply with the applicable construction methods of Section 2.02 Roadway Excavation, Formation Of Embankment and Disposal of Surplus Material, and Section 4.06 Bituminous Concrete, such as:
  - Cut Bituminous Concrete
  - Material for Tack Coat
  - Bituminous Concrete Class 1

### 4. Re-surface/Overlay Project

- Prior to disconnecting the existing loop confirm that the amplifier is operating properly and is programmed according to plan. Document loop operation. Report any discrepancies and malfunctions to Engineer.
- Remove all abandoned sawcut home-run wire from handhole.
- Sawcut new loop according to plan.
- Solder splice new loop wires to the existing lead-in cable and install new water resistant twist connectors as shown on the typical installation sheet. Do not re-use the removed connectors.
- Test the loop circuit resistance and inductance. Document results.
- Ensure the existing loop amplifier has re-tuned to the new loop and is operating according to plan.

**11.11.04 – Method of Measurement:**

1. Loop Vehicle Detector is measured by the number of installed, operating, tested, and accepted vehicle detector amplifiers of the type specified.
2. Loop Detector Sawcut is measured by the number of linear feet (meters) of installed, tested, operating, and accepted sawcut only where there is loop wire. Over-cuts at corners that do not contain wire are not measured.

**11.11.05 – Basis of Payment:**

1. Loop Vehicle Detector is paid at the contract unit price each of the type specified.
2. Loop Detector Sawcut is paid at the contract unit price per linear foot (meter). The price includes sawcut, loop wire, sealant, liquidtight flexible nonmetallic conduit, duct seal, water resistant splice connectors, testing, incidental material, equipment, and labor.

<u>Pay Item</u>	<u>Pay Unit</u>
Loop Vehicle Detector	ea. (ea.)
Loop Detector Sawcut	l.f. (m)

## **ITEM#1118012A REMOVAL AND/OR RELOCATION OF TRAFFIC SIGNAL EQUIPMENT**

Section 11.18: Replace the entire section with the following:

### **11.18.01 – Description:**

Remove all abandon traffic signal equipment. Restore the affected area. Where indicated on the plans remove and reinstall existing traffic signal equipment to the location(s) shown.

### **11.18.02 – Materials:**

The related sections of the following specifications apply to all incidental and additional material required for the proper relocation of existing equipment and the restoration of any area affected by this work.

- Division III, “Materials Section” of the Standard Specifications.
- Current Supplemental Specifications to the Standard Specifications.
- Applicable Special Provisions to the Standard Specifications.
- Current Department of Transportation, Functional Specifications for Traffic Control Equipment.

### **Article 11.18.03 - Construction Methods:**

Schedule/coordinate the removal and/or relocation of existing traffic signal equipment with the installation of new equipment to maintain uninterrupted traffic signal control. This includes but is not limited to vehicle signals and detectors, pedestrian signals and pushbuttons, co-ordination, and pre-emption.

#### **Abandoned Equipment**

The contract traffic signal plan usually does not show existing equipment that will be abandoned. Consult the existing traffic signal plan for the location of abandoned material especially messenger strand, conduit risers, and handholes that are a distance from the intersection. A copy of the existing plan is usually in the existing controller cabinet. If not, a plan is available from the Division of Traffic Engineering upon request.

Unless shown on the plans it is not necessary to remove abandoned conduit in-trench and conduit under-roadway

When a traffic signal support strand, rigid metal conduit, down guy, or other traffic signal equipment is attached to a utility pole, secure from the pole custodian permission to work on the pole. All applicable Public Utility Regulatory Authority (PURA) regulations and utility company requirements govern. Keep utility company apprised of the schedule and the nature of the work.

Remove all abandoned hardware, conduit risers, and down guys, Remove anchor rods, to 6” (150mm) below grade.

When underground material is removed, backfill the excavation with clean fill material. Compact the fill to eliminate settling. Remove entirely the following material: pedestal foundation; controller foundation; handhole; pressure sensitive vehicle detector complete with concrete base. Unless otherwise shown on the plan, remove steel pole and mast arm foundation to a depth of 2 feet (600mm) below grade. Restore the excavated area to a grade and condition compatible with the surrounding area.

- If in an unpaved area apply topsoil and establish turf in accordance with Section 9.44 and Section 9.50 of the Standard Specifications.
- If in pavement or sidewalk, restore the excavated area in compliance with the applicable Sections of Division II, “Construction Details” of the Standard Specifications.

Relocated Equipment

In the presence of the Engineer, verify the condition of all material that will be relocated and reused at the site. Carefully remove all material, fittings, and attachments in a manner to safeguard parts from damage or loss. Replace at no additional cost, all material which becomes damaged or lost during removal, storage, or reinstallation.

**Article 11.18.04 – Method of Measurement:**

This work will be measured as a Lump Sum.

**Article 11.18.05 – Basis of Payment:**

This work will be paid for at the contract lump sum price for “Removal and/or Relocation of Traffic Signal Equipment” which price shall include relocating signal equipment and associated hardware, all equipment, material, tools and labor incidental thereto. This price shall also include removing, loading, transporting, and unloading of signal equipment/materials designated for salvage and all equipment, material, tools and labor incidental thereto. This price shall also include removing and disposing of traffic signal equipment not to be salvaged and all equipment, material, tools and labor incidental thereto.

Payment is at the contract lump sum price for “Removal and/or Relocation of Traffic Signal Equipment” inclusive of all labor, vehicle usage, storage, and incidental material necessary for the complete removal of abandoned equipment/material and/or relocation of existing traffic signal equipment/material. Payment will also include the necessary labor, equipment, and material for the complete restoration of all affected areas.

Pay Item	Pay Unit
Removal and/or Relocation of Traffic Signal Equipment	L.S. (L.S.)

## **ITEM NO. 1118051A – TEMPORARY SIGNALIZATION (SITE NO. 1)**

### **Description:**

Provide Temporary Signalization (TS) at the intersections shown on the plans or as directed by the Engineer.

1. Existing Signalized Intersection: Keep each traffic signal completely operational at all times during construction through the use of existing signal equipment, temporary signal equipment, new signal equipment, or any combination thereof once TS has started as noted in the section labeled Duration.

2. Unsignalized Intersection: Provide TS during construction activities and convert the temporary condition to a permanent traffic signal upon project completion. Furnish, install, maintain, and relocate equipment to provide a complete temporary traffic signal, including but not limited to the necessary support structures, electrical energy, vehicle and pedestrian indications, vehicle and pedestrian detection, pavement markings, and signing.

### **Materials:**

- Pertinent articles of the Standard Specifications
- Supplemental Specifications and Special Provisions contained in this contract

### **Construction Methods:**

#### Preliminary Inspection

In the presence of the Engineer and a representative from the DOT Electrical Maintenance Office (Town representative for a Town owned signal), inspect and document the existing traffic signal's physical and operational condition prior to Temporary Signalization. Include but do not limit the inspection to the following:

- Controller Assembly (CA)
  - Controller Unit (CU)
  - Detection Equipment
  - Pre-emption Equipment
  - Coordination Equipment
- Vehicle and Pedestrian Signals
- Vehicle and Pedestrian Detectors
- Emergency Vehicle Pre-emption System (EVPS) \*
- Interconnect Cable and Splice Enclosures
- Support Structures
- Handholes, Conduit and Cable

It may be necessary to repair or replace equipment that is missing, damaged, or malfunctioning. Develop a checklist of items for replacement or repair after the inspection. If authorized by the Engineer, this work will be considered "Extra Work" under Article 1.09.04.

\* At a State owned signal the EVPS equipment is usually owned by the municipality. It is recommended to apprise the municipality of the inspection schedule and results.

### TS Plan

At least 30 days prior to implementation of each stage, submit a 1:40 (1:500 metric) scale TS plan for each location to the Engineer for review and comment. Include but do not limit the plan to the following:

- Survey Ties
- Dimensions of Lanes, Shoulders, and Islands
- Slope Limits
- Clearing and Grubbing Limits
- Signal Phasing and Timing
- Location of Signal Appurtenances such as Supports, Signal Heads, Pedestrian Push buttons, Pedestrian Signals
- Location of Signing and Pavement Markings (stop bars, lane lines, etc.)
- Location, method, and mode of Temporary Detection

Review of the TS plan does not relieve the Contractor of ensuring the TS meets the requirements of the MUTCD. A copy of the existing traffic signal plan for State-owned traffic signals is available from the Division of Traffic Engineering upon request. Request existing traffic signal plans for Town-owned traffic signals from the Town. Do not implement the TS plan until all review comments have been addressed.

### Earthwork

Perform the necessary clearing and grubbing and the grading of slopes required for the installation, maintenance, and removal of the TS equipment. After TS terminates restore the affected area to the prior condition and to the satisfaction of the Engineer.

### Maintenance and Protection of Traffic

Furnish, install, maintain, relocate, and remove signal-related signing (lane-use, signal ahead, NTOR, etc.) and pavement markings as needed. Install, relocate, and/or remove equipment in a manner to cause no hazard to pedestrians, traffic or property. Maintain traffic as specified in the Special Provisions "Prosecution and Progress" and "Maintenance and Protection of Traffic."

### Electrical Service and Telephone Service at Existing Signalized Intersections

If the electrical service or the telephone service source must be changed or relocated make all arrangements with the utility company and assume all charges. The party previously responsible for the monthly payment of service shall continue to be responsible during TS.

### Electrical Service at Unsignalized Intersections

Assume all charges and make all arrangements with the power company, including service requests, scheduling, and monthly bills in accordance with Section 10.00.12 and Section 10.00.13 of the Standard Specifications,. A metered service is recommended where TS equipment will be removed when no longer needed.

### Temporary Signalization

Furnish, install, maintain, relocate, and remove existing, temporary, and proposed traffic signal equipment and all necessary hardware; modify or furnish a new CA; reprogram the CU

phasing and timing; as many times as necessary for each stage/phase of construction to maintain and protect traffic and pedestrian movements as shown on the plans or as directed by the Engineer.

Inspection

When requested by the Engineer, the TS will be subject to a field review by a representative of the Division of Traffic Engineering and/or the Town, which may generate additional comments requiring revisions to the temporary signal.

Detection

Provide vehicle detection on the existing, temporary, and/or new roadway alignment for all intersection approaches that have existing detection, that have detection in the final condition as shown on the signal plan, or as directed by the Engineer. Keep existing pedestrian pushbuttons accessible and operational at all times during TS. Temporary Detection is described and is paid for under Item # 11112XXA - Temporary Detection (Site No. X)

Emergency Vehicle Pre-emption System (EVPS)

Furnish, install, maintain, relocate, and remove the equipment necessary to keep the existing EVPS operational as shown on the plan. Do not disconnect or alter the EVPS without the knowledge and concurrence of the Engineer and the EVPS owner. Schedule all EVPS relocations so that the system is out of service only when the Contractor is actively working. Ensure EVPS is returned to service and is completely operational at the end of the work day. Keep the EVPS owner apprised of all changes to the EVPS.

Coordination

Furnish, install, maintain, relocate, and remove the equipment necessary to keep the intersection coordinated to adjacent signals as shown on the plan. Do not disconnect the interconnect without the approval of the Engineer.

- Closed Loop System: If it is necessary to disconnect the communication cable, notify the Engineer and the Bridgeport Operation Center (BOC) or the Newington Operation Center (NOC) prior to disconnect and also after it is reconnected.
- Time Base System: Program and synchronize all Time Clock/Time Base Coordination (TC/TBC) units as necessary.

Maintenance

Once TS is in effect, assume maintenance responsibilities of the entire installation in accordance with Section 1.07.12 of the Standard Specifications. Notify the Engineer for the project records the date that Temporary Signalization begins. Notify the following parties that maintenance responsibility has been transferred to the Contractor:

Signal Owner  
CT DOT Electrical Maintenance Office or  
Town Representative

### Local Police Department

Provide the Engineer a list of telephone numbers of personnel who will be on-call during TS. Respond to traffic signal malfunctions by having a representative at the site within three hours from the initial contact. Within twenty-four (24) hours have the traffic signal operating according to plan.

If the Engineer determines that the nature of a malfunction requires immediate attention and/or the Contractor does not respond within three (3) hours, then an alternate maintenance service will be called to repair the signal. Expenses incurred by the alternate maintenance service for each call will be deducted from monies due to the Contractor with a minimum deduction of \$1,000. The alternate maintenance service may be the owner of the signal or another qualified electrical contractor.

### Duration

Temporary Signalization shall commence when any existing signal equipment is disturbed, relocated, or altered based on the inspection checklist in any way for the TS.

For intersections with a State furnished controller, TS terminates when the inspection of the permanent signal is complete and operational and is accepted by the Engineer. For intersections with a Contractor furnished controller, Temporary Signalization terminates at the beginning of the 30 day test period for the permanent signal.

### Ownership

Existing equipment, designated as salvage, remains the property of the owner. Salvable equipment will be removed and delivered to the owner upon completion of use. Temporary equipment supplied by the Contractor remains the Contractor's property unless noted otherwise.

### **Method of Measurement:**

Temporary Signalization shall be paid only once per site on a percentage of the contract Lump Sum price. Fifty percent (50%) shall be paid when TS is operational as shown on the plan or to the satisfaction of the Engineer. Fifty percent (50%) shall be paid when TS terminates.

### **Basis of Payment:**

This work shall be paid at the contract Lump Sum price for "Temporary Signalization (Site No.)" for each site. This price includes the preliminary inspection, TS plan for each stage/phase, furnishing, installing, maintaining, relocating and revising traffic signal equipment, controller assembly modifications, controller unit program changes such as phasing and timing, removing existing, temporary, and proposed traffic signal equipment, arrangements with utility companies, towns or cities including the fees necessary for electric and telephone service, clearing and grubbing, grading, area restoration and all necessary hardware, materials, labor, and work incidental thereto.

All material and work for signing and pavement markings is paid for under the appropriate Contract items.



All material and work necessary for vehicle and pedestrian detection for TS is paid for under item 11112XXA - Temporary Detection (Site No. X).

All Contractor supplied items that will remain the Contractor's property shall be included in the contract Lump Sum price for "Temporary Signalization."

Any items installed as part of the permanent installation are not paid for under this item but are paid for under the bid item for that work.

<u>Pay Item</u>	<u>Pay Unit</u>
Temporary Signalization (Site No.)	L.S.

**ITEM NO. 1206023A - REMOVAL AND RELOCATION OF EXISTING SIGNS**

Section 12.06 is supplemented as follows:

**Article 12.06.01 – Description is supplemented with the following:**

Work under this item shall consist of the removal and/or relocation of designated side-mounted extruded aluminum and sheet aluminum signs, sign posts, sign supports, and foundations where indicated on the plans or as directed by the Engineer. Work under this item shall also include furnishing and installing new sign posts and associated hardware for signs designated for relocation.

**Article 12.06.03 – Construction Methods is supplemented with the following:**

The Contractor shall take care during the removal and relocation of existing signs, sign posts, and sign supports that are to be relocated so that they are not damaged. Any material that is damaged shall be replaced by the Contractor at no cost to the State.

Foundations and other materials designated for removal shall be removed and disposed of by the Contractor as directed by the Engineer and in accordance with existing standards for Removal of Existing Signing.

Sheet aluminum signs designated for relocation are to be re-installed on new sign posts.

**Article 12.06.04 – Method of Measurement is supplemented with the following:**

Payment under Removal and Relocation of Existing Signs shall be at the contract lump sum price which shall include all extruded aluminum and sheet aluminum signs, sign posts, and sign supports designated for relocation, all new sign posts and associated hardware for signs designated for relocation, all extruded aluminum signs, sheet aluminum signs, sign posts and sign supports designated for scrap, and foundations and other materials designated for removal and disposal, and all work and equipment required.

**Article 12.06.05 – Basis of Payment is supplemented with the following:**

This work will be paid for at the contract lump sum price for “Removal and Relocation of Existing Signs” which price shall include relocating designated extruded aluminum and sheet aluminum signs, sign posts, and sign supports, providing new posts and associated hardware for relocated signs, removing and disposing of foundations and other materials, and all equipment, material, tools and labor incidental thereto. This price shall also include removing, loading, transporting, and unloading of extruded aluminum signs, sheet aluminum signs, sign posts, and sign supports designated for scrap and all equipment, material, tools and labor incidental thereto.

<u>Pay Item</u>	<u>Pay Unit</u>
Removal and Relocation of Existing Signs	L.S.

**ITEM #1208932A—SIGN FACE - SHEET ALUMINUM (TYPE IV  
RETROREFLECTIVE SHEETING)**

*Section 12.08 is supplemented and amended as follows:*

**12.08.01—Description:**

*Add the following:*

This item shall also include field testing of metal sign base posts as directed by the Engineer.

**12.08.03—Construction Methods:**

*Delete the last sentence and add the following:*

Metal sign base posts shall be whole and uncut. Sign base post embedment and reveal lengths shall be as shown on the plans. The Contractor shall drive the metal sign base posts by hand tools, by mechanical means or by auguring holes. If an obstruction is encountered while driving or placing the metal sign base post, the Contractor shall notify the Engineer who will determine whether the obstruction shall be removed, the sign base post or posts relocated, or the base post installation in ledge detail shall apply. Backfill shall be thoroughly tamped after the posts have been set level and plumb.

**Field Testing of Metal Sign Posts:** When the sign installations are complete, the Contractor shall notify the Engineer the Project is ready for field testing. Based on the number of posts in the Project, the Engineer will select random sign base posts which shall be removed by the Contractor for inspection and measurement by the Engineer. After such inspection is completed at each base post location, the Contractor shall restore or replace such portions of the work to the condition required by the Contract. Refer to the table in 12.08.05 for the number of posts to be field tested.

**12.08.04—Method of Measurement:**

*Add the following:*

The work required to expose and measure sign base post length and embedment depth using field testing methods, and restoration of such work, will not be measured for payment and shall be included in the general cost of the work.

**12.08.05—Basis of Payment:**

*Replace the entire Article with the following:*

This work will be paid for at the Contract unit price per square foot for “Sign Face - Sheet Aluminum” of the type specified complete in place, adjusted by multiplying by the applicable Pay Factor listed in the table below. The price for this work shall include the completed sign, metal sign post(s), span-mounted sign brackets and mast arm-mounted brackets, mounting hardware, including reinforcing plates, field testing, restoration and replacement of defective base post(s), and all materials, equipment, and work incidental thereto.

**Pay Factor Scale:** Work shall be considered defective whenever the base post length or base post embedment depth is less than the specified length by more than 2 inches. If the number of defects results in rejection, the Contractor shall remove and replace all metal sign base posts on the Project, at no cost to the Department.

**Number of Posts to be Tested and Pay Factors (Based on Number of Defects)**

<b>Number of Posts in Project =&gt;</b>	<b>51-100</b>	<b>101-250</b>	<b>251-1000</b>	<b>&gt;1000</b>
<b>Sample Size=&gt;</b>	<b>5 Posts</b>	<b>10 Posts</b>	<b>40 Posts</b>	<b>60 Posts</b>
0 Defects	1.0	1.0	1.025	1.025
1 Defect	0.9	0.95	0.975	0.983
2 Defects	Rejection	0.9	0.95	0.967
3 Defects	Rejection	Rejection	0.925	0.95
4 Defects	Rejection	Rejection	0.9	0.933
5 Defects	Rejection	Rejection	Rejection	0.917
6 Defects	Rejection	Rejection	Rejection	0.9
7 or more Defects	Rejection	Rejection	Rejection	Rejection

Note: Projects with 50 or fewer posts will not include field testing.

**ITEM #1302047A –RESET GATE BOXES**

**Description:** This work consists of resetting utility gate boxes to the required elevation and grades.

**Materials:** All materials conform to local utilities standards. CT Water Co. agrees to supply all materials required to reset a gate box.

**Construction Methods:**

General: The Contractor submits all required applications to the local utility companies for all work required to reset a gate box. Contact local utility companies prior to all work. All work must comply with local utility companies' standards and regulations. Work includes performing test pits, dewatering, excavation, making connections, and all other tasks required to reset a gate box.

**Method of Measurement:** "Reset Gate Box" will be measured for payment by the number of Gate Box that have been reset, in place, and approved by the local utility companies and/or the engineer.

**Basis of Payment:** "Reset Gate Box" will be paid for at the Contract Unit Price each, including all required work.

**Pay Item**  
RESET GATE BOX

**Pay Unit**  
EA.

**ITEM #1403501A – RESET MANHOLE (SANITARY SEWER)**

**Description:** This item shall consist of the adjustment to final grade the manhole frames and covers on Sanitary and Water Manholes, all as shown, specified or directed. It shall also consist of the furnishing and the installation of additional manhole riser sections, brick masonry, where necessary, and metal manhole extension rings to manhole frame; where indicated on the plans or directed by the engineer.

Reference to the “District” in this item refers to “The Borough of Naugatuck”.

**Materials:** Materials shall conform to the following:

BRICK UNITS – Shall conform to ASTM C-32, Grade MS

MORTAR – Shall conform to Section M.11

MANHOLE RISER SECTIONS – Shall conform to ASTM C-478

MANHOLE RUNGS (STEPS) – Shall be 14 inches x 10 7/8 inches forged aluminum safety rung fabricated from 6061-T6 aluminum alloy as manufactured by ALCOA, or equal; or copolymer polypropylene steps in conformance with ASTM D4101, Grade 60 steel reinforcing rod, ASTM A615, with epoxy coating, ASTM A-934/M-95. The steps shall be either Model PS-1B or PS2-PFSL as manufactured by M.A. Industries, Inc. or equal.

MANHOLE EXTENSION RINGS – Shall conform to Article M.08.02-5 Metal for Drainage Structures. The type of manhole extension rings will be designed so that the existing manhole cover, when set in place, will have substantially the same bearing, fitness and load carrying capacity as existed in the existing manhole frame. The extension rings shall be designed to fit into the original manhole frame resting specifically on the flange area that originally supported the manhole cover.

**Construction Methods:** The Contractor shall carefully excavate the manhole frame and cover and add or delete brick masonry as necessary to reset the frame and cover to the final grade.

The present cover slab or cone section may be reused if it is not damaged. If the cover slab or cone section is damaged, it shall be replaced by the Contractor, at his expense.

The Contractor may be required to “un-stack” the existing cone section so that riser sections can be added or deleted, where the change in grade is greater than 12 inches.

The distance between the proposed elevation of the manhole cover and the first manhole step shall be a minimum of 12 inches and a maximum of 16 inches.

Any material damaged by the Contractor shall be repaired or replaced by the Contractor at no cost to the Town, State or District.

Where the change in grade is 3 inches or less, metal manhole extension rings shall be used to raise and support the existing manhole covers to the grade of the proposed roadway surface without disturbing the existing manhole frame.

**Method of Measurement:** The work for “Reset Manhole (Sanitary Sewer)” and “Reset Manhole (Water)” will be measured for payment by the actual number of each manhole reset to grade and accepted by the Engineer.

**Basis of Payment:** This work will be paid for at the Contract unit price for each contract price for “Reset Manhole (Sanitary Sewer)” and “Reset Manhole (Water)” complete in place, which price shall include all labor and equipment necessary to incorporate the manhole into the work. It shall also include the clearing,

trenching, excavation and disposal of excavated materials, refilling trenches, furnishing additional material for refilling, grading, sheeting, bracing, pumping, and temporary and permanent resurfacing of disturbed areas.

The maximum 3 feet vertical adjustments shall not apply to adjusting sanitary sewer manholes, and there will be no extra compensation for adjusting a sanitary sewer manhole in excess of 3 feet.

**Pay Item**

Reset Manhole (Sanitary Sewer)

**PAY UNIT**

EA

## **ITEM #1507000A – PROTECTION AND SUPPORT OF EXISTING UTILITIES**

**Description:** Work under this item shall consist of protecting and providing temporary support of or relocating existing utilities located within and around the work zones of the new structure, as necessary, during excavation and construction of the culvert and or wingwalls, or as shown on the plans. Where directed by the Engineer and/or as necessary, the Contractor shall be responsible for providing protection and temporary support or relocation of the affected water and gas main(s) during construction of the culvert.

Work under this item shall also include coordination with the utility owners, determination of actual location of the utilities, and assessment of actual condition of the utilities to determine required protection and appropriate temporary support for the existing utilities.

**Construction Methods:** The Contractor shall design and construct the temporary support system for the utilities necessary to complete the new structure and shall be solely responsible for the adequacy of his design and erection scheme. The Contractor shall make himself aware of the actual condition of the utility pipes to assess required protection and to determine an appropriate means and method of temporarily supporting utilities. Should the Contractor propose to relocate utilities as an alternative in lieu of providing temporary support, the Contractor shall coordinate with and obtain full approval from the utility company. The relocation of the existing utilities will be accomplished in coordination with the utility company. The Contractor shall obtain all necessary permits for the performance of the work and shall assume all liabilities in connection therewith.

The Contractor shall coordinate all other construction activities with the utility company and allow them adequate time to perform whatever work, if any, is required of them. The Contractor shall insure that the utility service remains uninterrupted if and as required by the utility company.

The Contractor shall prepare and submit to the Engineer or any regulatory agency, working drawings showing the plan for construction of temporary support system or the plan for relocating utilities. Working drawings shall be developed and submitted in accordance with Article 1.05.02. These drawings shall bear the seal and signature of a Professional Engineer licensed in the State of Connecticut. No work pertaining to the protection and temporary support or relocation of utilities shall be started until approval from the Engineer and the utility company has been obtained. Approval from the Engineer or the utility company shall not serve to relieve the Contractor of any responsibility for the adequacy and safety of the proposed means and method, and to carry out the work in full accordance with the plans and specifications.

All parts of any temporary structure(s) used in this work shall be removed and properly disposed of off the site after work requiring its use is completed.

**Method of Measurement:** Work on this item will be paid for on a lump sum basis and will not be measured for payment.

**Basis of Payment:** This work will be paid for at the contract lump sum price for “Protection and Support of Existing Utilities”, which price shall include all coordination, materials, equipment,



tools, labor and work incidental thereto for the protection and temporary support or relocation of affected utilities during construction of the new structure. Work shall also include removal and proper disposal of any and all components of the constructed temporary support structures.

Pay Item

Protection and Support of Existing Utilities

Pay Unit

L.S.

**CTDOT PROJECT #87-146**  
**RUBBER AVENUE AT HOADLEY STREET AND MELBOURNE STREET**  
**TRAFFIC SIGNAL REPLACEMENT PROJECT**

**Naugatuck, CT**  
PROPOSAL continued

**SECTION I**

DBE Requirements

**Schedule 1**

**SPECIAL PROVISIONS**  
**DISADVANTAGED BUSINESS ENTERPRISES**  
**FOR FEDERAL FUNDED PROJECTS**

(For Municipal Advertised and Awarded Projects Only)

Revised – February 26, 2009

NOTE: Certain of the requirements and procedures stated in this special provision are applicable prior to the execution of the Contract document.

**I. ABBREVIATIONS AND DEFINITIONS AS USED IN THIS SPECIAL PROVISION**

- A. “CDOT” means the Connecticut Department of Transportation.
- B. “DOT” means the U.S. Department of Transportation, including the Office of the Secretary, the Federal Highway Administration (“FHWA”), the Federal Transit Administration (“FTA”), and the Federal Aviation Administration (“FAA”).
- C. “Broker” means a party acting as an agent for others in negotiating contracts, agreements, purchases, sales, etc., in return for a fee or commission.
- D. “Contract,” “agreement” or “subcontract” means a legally binding relationship obligating a seller to furnish supplies or services (including, but not limited to, construction and professional services) and the buyer to pay for them. For the purposes of this provision a lease for equipment or products is also considered to be a Contract.
- E. “Contractor,” means a consultant, second party or any other entity doing business with CDOT or, as the context may require, with another Contractor.
- F. “Disadvantaged Business Enterprise” (“DBE”) means a small business concern:
  - 1. That is at least 51 percent owned by one or more individuals who are both socially and economically disadvantaged or, in the case of a corporation, in which 51 percent of the stock of which is owned by one or more such individuals; and
  - 2. Whose management and daily business operations are controlled by one or more of the socially and economically disadvantaged individuals who own it.
- G. “DOT-assisted Contract” means any Contract between a recipient and a Contractor (at any tier) funded in whole or in part with DOT financial assistance, including letters of credit or loan guarantees.
- H. “Good Faith Efforts” means efforts to achieve a DBE goal or other requirement of this part which, by their scope, intensity, and appropriateness to the objective, can reasonably be expected to fulfill the program requirement. Refer to Appendix A of 49 Code of Federal Regulation (“CFR”)’ Part 26 - “Guidance Concerning Good Faith Efforts,” a copy of which is attached to this provision, for guidance as to what constitutes good faith efforts.

- I. “Small Business Concern” means, with respect to firms seeking to participate as DBEs in DOT-assisted Contracts, a small business concern as defined pursuant to Section 3 of the Small Business Act and Small Business Administration (“SBA”) regulations implementing it (13 CFR Part 121) that also does not exceed the cap on average annual gross receipts specified in 49 CFR Part 26, Section 26.65(b).
- J. “Socially and Economically Disadvantaged Individuals” means any individual who is a citizen (or lawfully admitted permanent resident) of the United States and who is -
  1. Any individual who CDOT finds on a case-by-case basis to be a socially and economically disadvantaged individual.
  2. Any individuals in the following groups, members of which are rebuttably presumed to be socially and economically disadvantaged:
    - i. “Black Americans,” which includes persons having origins in any of the Black racial groups of Africa;
    - ii. “Hispanic Americans,” which includes persons of Mexican, Puerto Rican, Cuban, Dominican, Central or South American, or other Spanish or Portuguese culture or origin, regardless of race;
    - iii. “Native Americans,” which includes persons who are American Indians, Eskimos, Aleuts, or Native Hawaiians;
    - iv. “Asian-Pacific Americans,” which includes persons whose origins are from Japan, China, Taiwan, Korea, Burma (Myanmar), Vietnam, Laos, Cambodia (Kampuchea), Thailand, Malaysia, Indonesia, the Philippines, Brunei, Samoa, Guam, the U.S. Trust Territories of the Pacific Islands (Republic of Palau), the Commonwealth of the Northern Marianas Islands, Macao, Fiji, Tonga, Kirbati, Juvalu, Nauru, Federated States of Micronesia, or Hong Kong;
    - v. “Subcontinent Asian Americans,” which includes persons whose origins are from India, Pakistan, Bangladesh, Bhutan, the Maldives Islands, Nepal or Sri Lanka;
    - vi. Women;
    - vii. Any additional groups whose members are designated as socially and economically disadvantaged by the SBA, at such time as the SBA designation becomes effective.

## II. GENERAL REQUIREMENTS

- A. The Contractor, sub-recipient or subcontractor shall not discriminate on the basis of race, color, national origin, or sex in the performance of this Contract. The Contractor shall carry out applicable requirements of 49 CFR Part 26 in the award and administration of DOT-assisted Contracts. Failure by the Contractor to carry out these requirements is a material breach of this Contract, which may result in the termination of this Contract or such other remedy, as the DOT deems appropriate.
- B. The Contractor shall cooperate with the Municipality, CDOT and DOT in implementing the requirements concerning DBE utilization on this Contract in accordance with Title 49 of the Code of Federal Regulations, Part 26 entitled “Participation by Disadvantaged Business Enterprises in Department of Transportation Financial Assistance Programs” (“49 CFR Part 26”), as revised. The Contractor shall also cooperate with the Municipality, CDOT and DOT in reviewing the Contractor’s activities relating to this Special Provision. This Special Provision is

in addition to all other equal opportunity employment requirements of this Contract

- C. The Contractor shall designate a liaison officer who will administer the Contractor's DBE program. Upon execution of this Contract, the name of the liaison officer shall be furnished in writing to the Municipality.
- D. For the purpose of this Special Provision, DBEs to be used to satisfy the DBE goal must be certified by CDOT's Division of Contract Compliance for the type(s) of work they will perform.
- E. If the Contractor allows work designated for DBE participation required under the terms of this Contract and required under III-B to be performed by other than the named DBE organization without concurrence from the Municipality, the Municipality will not pay the Contractor for the value of the work performed by organizations other than the designated DBE.
- F. At the completion of all Contract work, the Contractor shall submit a final report to the Municipality, indicating the work done by, and the dollars paid to DBEs. If the Contractor does not achieve the specified Contract goals for DBE participation, the Contractor shall also submit written documentation to the Municipality, detailing its good faith efforts to satisfy the goal that were made during the performance of the Contract. Documentation is to include but not be limited to the following:
  - 1. A detailed statement of the efforts made to select additional subcontracting opportunities to be performed by DBEs in order to increase the likelihood of achieving the stated goal.
  - 2. A detailed statement, including documentation of the efforts made to contact and solicit bids/proposals with CDOT certified DBEs, including the names, addresses, dates and telephone numbers of each DBE contacted, and a description of the information provided to each DBE regarding the scope of services and anticipated time schedule of work items proposed to be subcontracted and nature of response from firms contacted.
  - 3. Provide a detailed statement for each DBE that submitted a subcontract proposal, which the Contractor considered not to be acceptable stating the reasons for this conclusion.
  - 4. Provide documents to support contacts made with CDOT requesting assistance in satisfying the Contract specified goal.
  - 5. Provide documentation of all other efforts undertaken by the Contractor to meet the defined goal.
- G. Failure of the Contractor at the completion of all Contract work to have at least the specified percentage of this Contract performed by DBEs as required in III-B will result in the reduction in Contract payments to the Contractor by an amount determined by multiplying the total Contract value by the specified percentage required in III-B and subtracting from that result, the dollar payments for the work actually performed by DBEs. However, in instances where the Contractor can adequately document or substantiate its good faith efforts made to meet the specified percentage to the satisfaction of the Municipality, no reduction in payments will be imposed.
- H. All records must be retained for a period of three (3) years following acceptance by the Municipality of the Contract and shall be available at reasonable times and places for inspection by authorized representatives of the Municipality, CDOT and Federal agencies. If any litigation, claim, or audit is started before the expiration of the three (3) year period, the records shall be retained until all litigation, claims, or audits findings involving the records are resolved.
- I. Nothing contained herein, is intended to relieve any Contractor or subcontractor or material supplier or manufacturer from compliance with all applicable Federal and State legislation or provisions concerning equal employment opportunity, affirmative action, nondiscrimination and related subjects during the term of this Contract

### III. SPECIFIC REQUIREMENTS:

In order to increase the participation of DBEs, the Municipality requires the following

- A. The Contractor shall assure that certified DBEs will have an opportunity to compete for subcontract work on this Contract, particularly by arranging solicitations and time for the preparation of proposals for services to be provided so as to facilitate the participation of DBEs regardless if a Contract goal is specified or not.
- B. The DBE contact goal percentage for the Project is 10% (Construction) and 0% (Construction Inspection). The goal shall be based upon the total contract value. Compliance with this provision may be fulfilled when a DBE or any combination of DBEs perform work under Contract in accordance with 49 CFR Part 26, Subpart C, Section 26.55, as revised. Only work actually performed by and/or services provided by DBEs which are certified for such work and/or services can be counted toward the DBE goal. Supplies and equipment a DBE purchases or leases from the prime Contractor or Its affiliate can not be counted toward the goal.

If the Contractor does not document commitments, by subcontracting and/or procurement of material and/or services that at least equal the goal, it must document the good faith efforts that outline the steps it took to meet the goal in accordance with VII.

- C. Within 7 days after the bid opening, the low bidder shall indicate in writing to the Municipality, on the forms provided, the DBE(s) it will use to achieve the goal indicated in III-B. The submission shall include the name and address of each DBE that will participate in this Contract, a description of the work each will perform, the dollar amount of participation, and the percentage this is of the bid amount. This information shall be signed by the named DBE and the low bidder. The named DBE shall be from a list of certified DBEs available from CDOT. In addition, the named DBE(s) shall be certified to perform the type of work they will be contracted to do.
- D. The prime Contractor shall submit to the Municipality all requests for subcontractor approvals on the standard forms provided by the Municipality.

If the request for approval is for a DBE subcontractor for the purpose of meeting the Contract DBE goal, a copy of the legal Contract between the prime and the DBE subcontractor must be submitted along with the request for subcontractor approval. Any subsequent amendments or modifications of the Contract between the prime and the DBE subcontractor must also be submitted to the Municipality with an explanation of the change(s). The Contract must show items of work to be performed, unit prices and, if a partial item, the work involved by all parties.

In addition, the following documents are to be attached:

1. An explanation indicating who will purchase material.
  2. A statement explaining any method or arrangement for renting equipment. If rental is from a prime, a copy of the rental Agreement must be submitted.
  3. A statement addressing any special arrangements for manpower.
- E. The Contractor is required, should there be a change in a DBE they submitted in III-C, to submit documentation to the Municipality which will substantiate and justify the change, (i.e., documentation to provide a basis for the change for review and approval by the Municipality) prior to the implementation of the change. The Contractor must demonstrate that the originally named DBE

is unable to perform in conformity to the scope of service or is unwilling to perform, or is in default of its Contract, or is overextended on other jobs. **The Contractor's ability to negotiate a more advantageous agreement with another subcontractor is not a valid basis for change.** Documentation shall include a letter of release from the originally named DBE indicating the reason(s) for the release.

- F. Contractors subcontracting with DBEs to perform work or services as required by this Special Provision shall not terminate such firms without advising the Municipality in writing, and providing adequate documentation to substantiate the reasons for termination if the DBE has not started or completed the work or the services for which it has been contracted to perform.
- G. When a DBE is unable or unwilling to perform or is terminated for just cause the Contractor shall make good faith efforts to find other DBE opportunities to increase DBE participation to the extent necessary to at least satisfy the goal required by III-B.
- H. In instances where an alternate DBE is proposed, a revised submission to the Municipality together with the documentation required in III-C, III-D, and III-E, must be made for its review and approval.
- I. Each quarter after execution of the Contract, the Contractor shall submit a report to the Municipality indicating the work done by, and the dollars paid to the DBE for the current quarter and to date.
- J. Each contract that the Municipality signs with a contractor and each subcontract the Contractor signs with a subcontractor must include the following assurance: The contractor, sub-recipient or subcontractor shall not discriminate on the basis of race, color, national origin, or sex in the performance of this contract. The contractor shall carry out applicable requirements of 49CFR part 26 in the award and administration of DOT-assisted contract. Failure by the contractor to carry out these requirements is a material breach of this contract, which may result in the termination of this contract or such other remedy as the recipient deems appropriate.

#### IV. MATERIAL SUPPLIERS OR MANUFACTURERS

- A. If the Contractor elects to utilize a DBE supplier or manufacturer to satisfy a portion or all of the specified DBE goal, the Contractor must provide the Municipality with:
  - 1. An executed "Connecticut Department of Transportation DBE Supplier/Manufacturer Affidavit" (sample attached), and
  - 2. Substantiation of payments made to the supplier or manufacturer for materials used on the project.
- B. Credit for DBE suppliers is limited to 60% of the value of the material to be supplied, provided such material is obtained from a regular DBE dealer. A regular dealer is a firm that owns, operates, or maintains a store, warehouse or other establishment in which the materials or supplies required for the performance of the Contract are bought, kept in stock and regularly sold or leased to the public in the usual course of business. To be a regular dealer, the firm must engage in, as its principal business, and in its own name, the purchase and sale of the products in question. A regular dealer in such bulk items as steel, cement, gravel, stone and petroleum products, need not keep such products in stock if it owns or operates distribution equipment Brokers and packagers shall not be regarded as material suppliers or manufacturers.
- C. Credit for DBE manufacturers is 100% of the value of the manufactured product. A manufacturer is a firm that operates or maintains a factory or establishment that produces on the premises the materials or supplies obtained by the Municipality, Department of Transportation or Contractor.

#### V. NON-MANUFACTURING OR NON-SUPPLIER DBE CREDIT:

- A. Contractors may count towards their DBE goals the following expenditures with DBEs that are not

manufacturers or suppliers:

1. Reasonable fees or commissions charged for providing a bona fide service such as professional, technical, consultant or managerial services and assistance in the procurement of essential personnel, facilities, equipment materials or supplies necessary for the performance of the Contract provided that the fee or commission is determined by the Municipality to be reasonable and consistent with fees customarily allowed for similar services.
2. The fees charged for delivery of materials and supplies required on a job site (but not the cost of the materials and supplies themselves) when the hauler, trucker, or delivery service is a DBE but is not also the manufacturer of or a regular dealer in the materials and supplies, provided that the fees are determined by the Municipality to be reasonable and not excessive as compared with fees customarily allowed for similar services.
3. The fees or commissions charged for providing bonds or insurance specifically required for the performance of the Contract, provided that the fees or commissions are determined by the Municipality to be reasonable and not excessive as compared with fees customarily allowed for similar services.

## VI. BROKERING

- A. Brokering of work by DBEs who have been approved to perform subcontract work with their own workforce and equipment is not allowed, and is a Contract violation.
- B. DBEs involved in the brokering of subcontract work that they were approved to perform may be decertified.
- C. Firms involved in the brokering of work whether they are DBEs and/or majority firms who engage in willful falsification, distortion or misrepresentation with respect to any facts related to the project shall be referred to the U.S. Department of Transportation's Office of the Inspector General for prosecution under Title 18, U.S. Code, Section 10.20.

## VII. REVIEW OF PRE-AWARD GOOD FAITH EFFORTS

- A. If the Contractor does not document commitments by subcontracting and/or procurement of material and/or services that at least equal the goal stipulated in III-B, the Contractor must document the good faith efforts that outline the specific steps it took to meet the goal. The Contract will be awarded to the Contractor if its good faith efforts are deemed satisfactory and approved by CDOT. To obtain such an exception, the Contractor must submit an application to the Municipality, which documents the specific good faith efforts that were made to meet the DEE goal. **Application form for Review of Pre-Award Good Faith Efforts is attached hereto.**

The application must include the following documentation:

1. a statement setting forth in detail which parts, if any, of the Contract were reserved by the Contractor and not available for subcontracting;
2. a statement setting forth all parts of the Contract that are likely to be sublet;
3. a statement setting forth in detail the efforts made to select subcontracting work in order to likely achieve the stated goal;
4. copies of all letters sent to DBEs;



5. a statement listing the dates and DBEs that were contacted by telephone and the result of each contact;
6. a statement listing the dates and DBEs that were contacted by means other than telephone and the result of each contact;
7. copies of letters received from DBEs in which they declined to bid;
8. a statement setting forth the facts with respect to each DBE bid received and the reason(s) any such bid was declined;
9. a statement setting forth the dates that calls were made to CDOT's Division of Contract Compliance seeking DBE referrals and the result of each such call; and
10. any information of a similar nature relevant to the application.

The review of the Contractor's good faith efforts may require an extension of time for award of the Contract. In such a circumstance, and in the absence of other reasons not to grant the extension or make the award, the Municipality will agree to the needed extension(s) of time for the award of the Contract, provided the Contractor and the surety also agree to such extension(s).

- B. Upon receipt of the submission of an application for review of pre-award good faith efforts, the Municipality shall submit the documentation to CDOT initiating unit for submission to the CDOT Division of Contract Compliance. CDOT Division of Contract Compliance will review the documents and determine if the package is complete, accurate and adequately documents the Contractor's good faith efforts. Within fourteen (14) days of receipt of the documentation the CDOT Division of Contract Compliance shall notify the Contractor by certified mail of the approval or denial of its good faith efforts.
- C. If the Contractor's application is denied, the Contractor shall have seven (7) days upon receipt of written notification of denial to request administrative reconsideration. The Contractor's request for administrative reconsideration should be sent in writing to the Municipality. The Municipality will forward the Contractor's reconsideration request to the CDOT initiating unit for submission to the DBE Screening Committee. The DBE Screening Committee will schedule a meeting within fourteen (14) days from receipt of the Contractor's request for administrative reconsideration and advise the Contractor of the date, time and location of the meeting. At this meeting the Contractor will be provided with the opportunity to present written documentation and/or argument concerning the issue of whether it made adequate good faith efforts to meet the goal. Within seven (7) days following the reconsideration meeting, the chairperson of the DBE Screening Committee will send the contractor via certified mail a written decision on its reconsideration request, explaining the basis of finding either for or against the request. The DBE Screening Committee's decision is final. **If the reconsideration is denied, the Contractor shall indicate in writing to the Municipality within fourteen (14) days of receipt of written notification of denial, the DBEs it will use to achieve the goal indicated in III-B.**
- D. Approval of pre-execution good faith efforts does not relieve the Contractor from its obligation to make additional good faith efforts to achieve the DBE goal should contracting opportunities arise during actual performance of the Contract work.

- I. When, as a recipient, you establish a Contract goal on a DOT-assisted Contract, a Bidder/Contractor must, in order to be responsible and/or responsive, make good faith efforts to meet the goal. The Bidder/Contractor can meet this requirement in either of two ways. First, the Bidder/Contractor can meet the goal, documenting commitments for participation by DBE firms sufficient for this purpose. Second, even if it doesn't meet the goal, the Bidder/Contractor can document adequate good faith efforts. This means that the Bidder/Contractor must show that it took all necessary and reasonable steps to achieve a DBE goal or other requirement of this part which, by their scope, intensity, and appropriateness to the objective, could reasonably be expected to obtain sufficient DBE participation, even if they were not fully successful.
- II. In any situation in which you have established a Contract goal, Part 26 requires you to use the good faith efforts mechanism of this part. As a recipient, it is up to you to make a fair and reasonable judgment whether a Bidder/Contractor that did not meet the goal made adequate good faith efforts. It is important for you to consider the quality, quantity, and intensity of the different kinds of efforts that the Bidder/Contractor has made. The efforts employed by the Bidder/Contractor should be those that one could reasonably expect a Bidder/Contractor to take if the Bidder/Contractor were actively and aggressively trying to obtain DBE participation sufficient to meet the DBE Contract goal. Mere pro forma efforts are not good faith efforts to meet the DBE Contract requirements. We emphasize, however, that your determination concerning the sufficiency of the firm's good faith efforts is a judgment call: meeting quantitative formulas is not required.
- III. The Department also strongly cautions you against requiring that a Bidder/Contractor meet a Contract goal (i.e., obtain a specified amount of DBE participation) in order to be awarded a Contract, even though the Bidder/Contractor makes an adequate good faith efforts showing. This rule specifically prohibits you from ignoring bona fide good faith efforts.
- IV. The following is a list of types of actions which you should consider as part of the Bidder/Contractor's good faith efforts to obtain DBE participation. it is not intended to be a mandatory checklist, nor is it intended to be exclusive or exhaustive. Other factors or types of efforts may be relevant in appropriate cases.
  - A. Soliciting through all reasonable and available means (e.g. attendance at pre-bid meetings, advertising and/or written notices) the interest of all certified DBEs who have the capability to perform the work of the Contract. The Bidder/Contractor must solicit this interest within sufficient time to allow the DBEs to respond to the solicitation. The Bidder/Contractor must determine with certainty if the DBEs are interested by taking appropriate steps to follow up initial solicitations.
  - B. Selecting portions of the work to be performed by DBEs in order to increase the likelihood that the DBE goals will be achieved. This includes, where appropriate, breaking out Contract work items into economically feasible units to facilitate DBE participation, even when the prime Contractor might otherwise prefer to perform these work items with its own forces.
  - C. Providing interested DBEs with adequate information about the plans, specifications, and requirements of the Contract in a timely manner to assist them in responding to a solicitation.
  - D. (1) Negotiating in good faith with interested DBEs. It is the Bidder/Contractor's responsibility to make a portion of the work available to DBE subcontractors and suppliers and to select those portions of the work or material needs consistent with the available DBE subcontractors and suppliers, so as to facilitate DBE participation. Evidence of such negotiation includes the names, addresses, and telephone numbers of DBEs that were considered; a description of the information provided regarding the plans and specifications for the work selected for subcontracting; and evidence as to why additional agreements could not be reached for DBEs to perform the work.  
  
(2) A Bidder/Contractor using good business judgment would consider a number of factors in negotiating with subcontractors, including DBE subcontractors, and would take a firm's price and capabilities as

well as Contract goals into consideration. However, the fact that there may be some additional costs involved in finding and using DBEs is not in itself sufficient reason for a Bidder/Contractor's failure to meet the Contract DBE goal, as long as such costs are reasonable. Also, the ability or desire of a prime Contractor to perform the work of a Contract with its own organization does not relieve the Bidder/Contractor of the responsibility to make good faith efforts. Prime Contractors are not, however, required to accept higher quotes from DBEs if the price difference is excessive or unreasonable.

- E. Not rejecting DBEs as being unqualified without sound reasons based on a thorough investigation of their capabilities. The Contractor's standing within its industry, membership in specific groups, organizations, or associations and political or social affiliations (for example union vs. non-union employee status) are not legitimate causes for the rejection or non-solicitation of bids/proposals in the Contractor's efforts to meet the project goal.
- F. Making efforts to assist interested DBEs in obtaining bonding, lines of credit, or insurance as required by the recipient or Contractor.
- G. Making efforts to assist interested DBEs in obtaining necessary equipment, supplies, materials, or related assistance or services.
- H. Effectively using the services of available minority/women community organizations; minority/women Contractors' groups local, state, and Federal minority/women business assistance offices; and other organizations as allowed on a case-by-case basis to provide assistance in the recruitment and placement of DBEs.
- V. In determining whether a Bidder/Contractor has made good faith efforts, you may take into account the performance of other Bidder/Contractors in meeting the Contract For example, when the apparent successful Bidder/Contractor fails to meet the Contract goal, but others meet it, you may reasonably raise the question of whether, with additional reasonable efforts, the apparent successful Bidder/Contractor could have met the goal. If the apparent successful Bidder/Contractor fails to meet the goal, but meets or exceeds the average DBE participation obtained by other Bidder/Contractors, you may view this, in conjunction with other factors, as evidence of the apparent successful Bidder/Contractor having made good faith efforts.

CONNECTICUT DEPARTMENT OF TRANSPORTATION  
DBE SUPPLIER/MANUFACTURER AFFIDAVIT

This affidavit must be completed by the State Contractor's DBE notarized and attached to the Contractor's request to utilize a DBE supplier a manufacturer as a credit towards its DBE Contract requirements: failure to do so will result in not receiving credit towards the Contract DBE requirement.

State Project No. \_\_\_\_\_

Federal Aid Project No. \_\_\_\_\_

Description of Project \_\_\_\_\_

I, \_\_\_\_\_, acting in behalf of \_\_\_\_\_  
(Name of person signing Affidavit) (DBE person, firm, association or organization)  
of which I am the \_\_\_\_\_ certify and affirm that \_\_\_\_\_  
(Title of Person) (DBE person, firm, association or organization)

is a certified Connecticut Department of Transportation DBE. I further certify and affirm that I have read and understand 49 CFR Sec. 26.55(e)(2), as the same may be revised.

I further certify and affirm that \_\_\_\_\_ will assume the actual  
(DBE person, firm, association or organization)  
contractual responsibility for the provision of the materials and/or supplies sought by \_\_\_\_\_.  
(State Contractor)

If a manufacturer, I produce goods from raw materials or substantially alter them before resale, or if a supplier, I perform a commercially use function in the supply process.

I understand that false statements made herein are punishable by Law (Sec. 53a-157), CGS, as revised).

\_\_\_\_\_  
(Name of Organization or Firm)

\_\_\_\_\_  
(Signature & Title of Official making the Affidavit)

Subscribed and sworn to before me, this \_\_\_\_\_ day of \_\_\_\_\_ 20 \_\_\_\_.

Notary Public (Commissioner of the Superior Court)  
My Commission Expires

**CERTIFICATE OF CORPORATION**

I, \_\_\_\_\_, certify that I am the \_\_\_\_\_ (Official)  
of the Organization named in the foregoing instrument; that I have been duly authorized to affix the  
seal of the Organization to such papers as require the seal; that \_\_\_\_\_, who signed  
said instrument on behalf of the Organization, was then \_\_\_\_\_ of said Organization;  
that said instrument was duly signed for and in behalf of said Organization by authority of its governing body  
and is within the scope of its organizational powers.

\_\_\_\_\_  
(Signature of Person Certifying)

\_\_\_\_\_  
(Date)

**CTDOT PROJECT #87-146**  
**RUBBER AVENUE AT HOADLEY STREET AND MELBOURNE STREET**  
**TRAFFIC SIGNAL REPLACEMENT PROJECT**  
**Naugatuck, CT**  
**PROPOSAL continued**

**SECTION J**

CTDOT Requirements  
(To Be Completed by Low Bidder)

# CONTRACTOR'S PROPOSED PROGRESS CHART – HIGHWAY CONSTRUCTION BAR CHART

Project Number(s): \_\_\_\_\_

Town(s) of: \_\_\_\_\_

Date Submitted: \_\_\_\_\_

Description: \_\_\_\_\_

Operation	Quantity	Duration
Organization		
Clearing & Grubbing		
Earth Excavation		
Rock Excavation		
Channel Excavation		
Borrow		
Drainage (Trench, Pipe)		
Pile Driving		
Footing		
Abutments & Wings		
Steel Erection		
Floor Slabs		
Concrete Pavement		
Bit. Conc. Pavement		
Bridge Railing		
Curbing		
Sidewalk		
Fencing		
Electrical Work		
Traffic Items		
Misc. & Clean up		

Equipment to expect to use:  
 \_\_\_\_\_  
 \_\_\_\_\_  
 \_\_\_\_\_

Calendar Days  
 Total Calendar Days: \_\_\_\_\_  
 Signed By: \_\_\_\_\_

**ANTICIPATED SOURCE  
OF MATERIAL**

REV. 8/98  
PRINTED ON RECYCLED PAPER

STATE OF CONNECTICUT  
**DEPARTMENT OF TRANSPORTATION**  
P.O. BOX 317546  
NEWINGTON, CT 06111-7546

PROJECT NUMBER
TOWN

MATERIALS	SOURCE OF SUPPLY AND MAILING ADDRESS PG. 1 of 2
AGGREGATES:	
Coarse	
Fine	
BITUMINOUS CONCRETE	
BITUMEN:	
Asphalt Cement	
Asphalt Cutbacks	
Emulsion	
Tar	
BRICK	
CEMENT - PORTLAND	
Type I	
Type II	
Type 1A	
Type IIA	
TYPE OF DELIVERY:	
Truck	
R.R. Car	
CONCRETE BLOCKS	
CONCRETE, PORTLAND CEMENT	
CURING MATERIAL:	
Mats	
Paper	
Compound	
Other	
DAMP PROOFING and/or WATERPROOFING:	
Primer	
Seal	
Fabric	
FENCE:	
Property or Wire	
Posts: Steel	
Wood	
Chain Link	
Fittings for Chain Link	
GRAVEL	
GUIDE RAIL:	
Wire Rope	
Fittings	
Posts:	
Metal	
Wood	
JOINT FILLER	
JOINT SEALER	
LOAD TRANSFER UNIT	
METAL FLASHING	
METAL BEAM TYPE RAIL (BRIDGE)	
METAL BEAM TYPE RAIL	
METAL BRIDGE RAIL	
OVERHEAD SIGN SUPPORTS	
PAINT:	
2nd Prime Coat (Field)	
1st Field Coat	

MATERIALS	SOURCE OF SUPPLY AND MAILING ADDRESS PG. 2 of 2
PILING:	
Sheets	
Bearing	
Pipe	
Wood (Pressure Treated)	
Precast, Prestressed	
PIPE:	
C.C.M.	
Cast Iron	
Reinf. Concrete	
Vitrified Clay	
PRECAST, PRESTRESSED UNITS	
STEEL:	
Bar Mat Fabric and/or Wire Mesh	
Metal Cribbing	
Reinforcement	
Scuppers	
SHEAR CONNECTORS:	
Spiral	
Welded	
STRUCTURAL (BRIDGES)	
STRUCTURAL (Side mounted sign supports)	
CONTRACTOR	
SIGNED BY	
DATE	

NOTE: Items not listed above shall be listed below.



**STATE OF CONNECTICUT**  
**Certificate of Compliance with**  
**Connecticut General Statute Section 31 - 57b**

I hereby certify that all of the statements herein contained below have been examined by me, and to the best of my knowledge and belief are true and correct.

The \_\_\_\_\_ **HAS / HAS NOT**  
*Company Name* (Cross out Non-applicable)

been cited for three (3) or more willful or serious or serious violations of any Occupational Safety and Health Act (OSHA) or of any standard, order or regulation promulgated pursuant to such act, during the three year period preceding the bid, provided such violations were cited in accordance with the provisions of any State Occupational Safety and Health Act of 1970, and not abated within the time fixed by the citation and such citation has not been set aside following appeal to the appropriate agency of court having jurisdiction or **HAS / HAS NOT** (Cross out Non-applicable) received one or more criminal convictions related to the injury or death of any employee in the three-year period preceding the bid.

The list of violations (if applicable) is attached.

\_\_\_\_\_  
*(Name of Firm, Organization or Corporation)*

**Signed:**

\_\_\_\_\_  
*Written Signature:*

\_\_\_\_\_  
*Name Typed:*

\_\_\_\_\_  
*(Corporation Seal)*

**Title:**

\_\_\_\_\_  
*(Title of Above Person, typed)*

**Dated:**

*State of* \_\_\_\_\_ )

*County of* \_\_\_\_\_ )

*ss:*

*A.D., 20* \_\_\_\_\_ )

Sworn to and personally appeared before me for the above, \_\_\_\_\_,  
*(Name of Firm, Organization, Corporation)*

Signer and Sealer of the foregoing instrument of and acknowledged the same to be the free act and deed of

\_\_\_\_\_, and his/her free act and deed as  
*(Name of Person appearing in front of Notary or Clerk)*

\_\_\_\_\_  
*(Title of Person appearing in front of Notary or Clerk)*

My Commission Expires:

\_\_\_\_\_  
*(Notary Public)*

\_\_\_\_\_  
*(Seal)*

**AFFIRMATIVE ACTION PROGRAM CERTIFICATION**

City/Town of \_\_\_\_\_  
\_\_\_\_\_

Firm Name: \_\_\_\_\_  
\_\_\_\_\_

Address: \_\_\_\_\_  
\_\_\_\_\_

Project Description: \_\_\_\_\_  
\_\_\_\_\_  
\_\_\_\_\_

Bid Amount: \_\_\_\_\_

Date: \_\_\_\_\_

I \_\_\_\_\_ of \_\_\_\_\_  
(Name of Person) (Name of Firm)

intend to honor our Affirmative Action Program on file with the Connecticut Department of Transportation, Office of Contract Compliance. I further certify that our Affirmative Action Program is current and that the last approval was on (Date) \_\_\_\_\_, 20\_\_\_\_ and it expires on (Date) \_\_\_\_\_, 20\_\_\_\_.

Signed By: \_\_\_\_\_

Title: \_\_\_\_\_

EEO Officer: \_\_\_\_\_

CON-32 REV. 11/07  
STATE OF CONNECTICUT  
DEPARTMENT OF TRANSPORTATION

**CERTIFICATE OF INSURANCE**

This is to certify that the Insurance Company named herein has issued to the named insured the policies listed below, that these policies are written in accordance with the Insurance Company's standard policies and endorsements, except as indicated below or as noted in the attachments hereto, which policies and endorsements will be made available to the Department of Transportation upon request, that they provide coverages and limits of liability shown with respect to the hazards indicated, that they are in force on this date, and that this Certificate is furnished in accordance with and for the purpose of satisfying the requirements of the Department of Transportation in connection with the award and the performance of any contract or agreement, or the issuance of any permit or authorization by the Transportation Commissioner or duly authorized agent.

The Insurance Company has a right and duty to defend the insured against any suit seeking damages (or under Workers' Compensation benefits) to which the referenced insurance policy applies and may investigate and settle any claim or suit as they deem appropriate. The Insurance Company's duty to defend or settle any claim or suit ends when the applicable limit of liability has been exhausted in the payment of judgments or settlements.

NAME OF INSURED \_\_\_\_\_  
ADDRESS \_\_\_\_\_ CITY \_\_\_\_\_ STATE \_\_\_\_\_

HAZARDS	POLICY NUMBER	EFFECTIVE DATE	EXPIRATION DATE	COVERAGES AND LIMITS OF LIABILITY BODILY INJURY LIABILITY AND PROPERTY DAMAGE LIABILITY	
				ALL PERSONS / ALL DAMAGES EACH ACCIDENT or OCCURRENCE	AGGREGATE
<b>A</b> OWNER'S AND CONTRACTOR'S PROTECTIVE LIABILITY FOR AND IN THE NAME OF THE STATE OF CONN. (1)(2) SEE BELOW					
<b>*B</b> COMMERCIAL GENERAL LIABILITY (1) SEE BELOW					
<b>*C</b> EXPLOSION, COLLAPSE, OR UNDERGROUND DAMAGE LIABILITY(1) SEE BELOW					
<b>*D</b> AUTOMOBILE LIABILITY OWNED AUTOMOBILES HIRED AUTOMOBILES NON-OWNED AUTOMOBILES (1) SEE BELOW					
<b>*E</b> RAILROAD PROTECTIVE LIABILITY (1) (2) SEE BELOW					
<b>*F</b> EXCESS/UMBRELLA LIABILITY (1) SEE BELOW					
<b>G</b> VALUABLE PAPERS and RECORDS	XXXXXXXXXXXXXX	XXXXXXX	XXXXXXX	POSSESSION	ALL OTHER
VALUABLE PAPERS and RECORDS					
<b>H</b> BLASTING (1) SEE BELOW					
<b>I</b> ** WORKERS' COMPENSATION				STATUTORY COVERAGES AND LIMITS	
<b>J</b>					

\* State of Connecticut Is Named as Additional Insured.

\*\* Compensation Commissioner's Certificate shall be supplied herewith by self-insured party.

**Note: If Excess/Umbrella Liability Insurance is needed to meet the Agreement/Contract, etc. minimum requirements, complete Section F above.**

**Check** This Certificate is issued in accordance with the terms of:

- Construction Contracts     
  Lease Agreement Rights of Way     
  Demolition Contracts  
 Permit Work No. \_\_\_\_\_     
  Project No. \_\_\_\_\_     
  Agree No. \_\_\_\_\_  
 Engineering     
  Other Specify & including all operations incidental thereto.

PARTY FOR NOTICE Bureau: \_\_\_\_\_ Unit: \_\_\_\_\_ Name: \_\_\_\_\_

(1) It is agreed that the herein named Insurance Company will not use the defense of sovereign immunity in the adjustment of claims or in the defense of any suit brought against the State, unless requested to do so in writing by the State.

(2) It is agreed that the Insurance Company will bill premiums and audit charges earned under the protective liability policy(ies) to the above named insured; however, if named insured is different from the vendor, consultant, contractor or party of record, the vendor, consultant, contractor or party of record will be billed.

IN THE EVENT OF ANY REDUCTION IN LIMITS, CANCELLATION OF OR FAILURE TO RENEW ANY ONE OR MORE OF SAID POLICIES THE \_\_\_\_\_ (INSURANCE COMPANY) SHALL GIVE NOT LESS THAN THIRTY DAYS WRITTEN NOTICE TO THE PARTY FOR NOTICE TO WHOM THIS CERTIFICATE IS ISSUED OF SUCH REDUCTION IN LIMITS, CANCELLATION, OR FAILURE TO RENEW.

DATED THIS \_\_\_\_\_ DAY OF \_\_\_\_\_ \_\_\_\_\_ (Insurance Company)

ISSUED TO: CONNECTICUT DEPARTMENT OF TRANSPORTATION  
CONTRACT ADMINISTRATION  
2800 BERLIN TURNPIKE  
NEWINGTON, CT 06111

 Printed on recycled or recovered paper. \_\_\_\_\_ (Address)  
 \_\_\_\_\_ (Agency)  
 \_\_\_\_\_ (Address)  
 \_\_\_\_\_ (Authorized Agent's Name & Signature)

## CONNECTICUT DEPARTMENT OF TRANSPORTATION (CTDOT)

### PRE-AWARD DBE COMMITMENT APPROVAL REQUEST

TO BE SUBMITTED WITHIN THE TIME FRAME INDICATED IN THE BID DOCUMENTS

Only certified DBE firms and only for work which they have been certified for will be approved by CDOT toward the goal. Department's DBE directory is available on CTDOT's website or by calling 860-594-2171

Sheet \_\_\_\_\_ of \_\_\_\_\_

CDOT Project Number (s): \_\_\_\_\_

DBE Subcontractor: \_\_\_\_\_ FEIN Number: \_\_\_\_\_

Town(s) of: \_\_\_\_\_

NAICS Code (s) associated with this submission: \_\_\_\_\_

Submitted By (Prime): \_\_\_\_\_

Address: \_\_\_\_\_

Original Bid (\$): \_\_\_\_\_

Is this DBE firm a 1st or 2nd tier subcontractor? 1st 2nd\*

Dollar amount subcontracted to this DBE firm (\$): \_\_\_\_\_

Dollar amount requested for CREDIT for this DBE Firm (\$): \_\_\_\_\_ \*\*

\* The CDOT prefers 1st tier subcontractors; however, credit for 2nd tier DBE firms will be approved provided this page is signed by both the prime and the DBE firm, the 1st tier subcontractor is identified, the extent of the 2nd tier work is clearly identified, and the prime makes the assertion that regardless of its arrangement with the 1st tier subcontractor, this DBE firm will be used and its replacement is subject to the conditions of the DBE specification and contract requirements.

\*\* Please be advised that by submitting this form you (the prime) agree that the total Credited amount will be the amount of commitment and will be measured by the Commercially Useful Function the Subcontractor performs.

<u>Item Number &amp; Description</u>	<u>Is This item Partial Yes No</u>	<u>Firm Type Code</u> <b>***</b>	<u>Quantity and Unit of item as bid</u>	<u>Contract Unit Price</u>	<u>Quantity and Unit for item Subcontracted</u>	<u>Subcontract Unit Price</u>	<u>Total Item price subcontracted****</u>	<u>Total item prices credited to the subcontractor*****</u>

If any of the items above are checked **Yes** as to **Partial**, please use the space provided or use an attachment to offer an explanation of the work involved. Also please identify who is responsible for the remainder of the partial items.

**\*\*\*** Firm Type Code: **S** (subcontractor), **M** (manufacturer), **P** (supplier), **T** (trucking), **V** (services) Any DBE Trucking firm (**T**) nominated on this form must self-perform not less than 30% of their contract value.

**\*\*\*\*** In instances where the Prime is paying the Subcontractor a higher unit price than the bid, by submitting this form the Prime agrees to the higher subcontracted price without additional costs to the Department.

**\*\*\*\*\*** The credited amount includes adjustments for supply items (60%) or items further subcontracted to NON-DBE firms.

**\*\*\*\*** Is this DBE Purchasing any Material or Leasing any Equipment from the Prime or any of the Prime's Affiliates?      YES      If YES, state the amount and DO NOT include the Amount: \$ \_\_\_\_\_  
NO      amount in the amount toward the goal.

\_\_\_\_\_  
Signature of Prime Contractor, Title

\_\_\_\_\_  
Date

\_\_\_\_\_  
Signature of Subcontractor, Title

\_\_\_\_\_  
Date

After this submittal is approved by the Department, any proposed changes to it must be submitted to the Department for approval.

**CTDOT PROJECT #87-146**  
**RUBBER AVENUE AT HOADLEY STREET AND MELBOURNE STREET**  
**TRAFFIC SIGNAL REPLACEMENT PROJECT**  
**Naugatuck, CT**  
**PROPOSAL continued**

**SECTION K**

FHWA Requirements and Prevailing Wage Rates

## **Construction Contracts - Required Contract Provisions (FHWA Funded Contracts)**

### **Index**

1. Federal Highway Administration (FHWA) Form 1273 (Revised May 1, 2012)
2. Title VI of the Civil Rights Act of 1964 / Nondiscrimination Requirements
3. Contractor Work Force Utilization (Federal Executive Order 11246) / Specific Equal Employment Opportunity
4. Requirements of Title 49, CFR , Part 26, Participation by DBEs
5. Contract Wage Rates
6. Americans with Disabilities Act of 1990, as Amended
7. Connecticut Statutory Labor Requirements
  - a. Construction, Alteration or Repair of Public Works Projects; Wage Rates
  - b. Debarment List - Limitation on Awarding Contracts
  - c. Construction Safety and Health Course
  - d. Awarding of Contracts to Occupational Safety and Health Law Violators Prohibited
  - e. Residents Preference in Work on Other Public Facilities (Not Applicable to Federal Aid Contracts)
8. Tax Liability - Contractor's Exempt Purchase Certificate (CERT – 141)
9. Executive Orders (State of CT)
10. Non Discrimination Requirement (pursuant to section 4a-60 and 4a-60a of the Connecticut General Statutes, as revised)
11. Whistleblower Provision
12. Connecticut Freedom of Information Act
  - a. Disclosure of Records
  - b. Confidential Information
13. Service of Process
14. Substitution of Securities for Retainages on State Contracts and Subcontracts
15. Health Insurance Portability and Accountability Act of 1996 (HIPAA)
16. Forum and Choice of Law
17. Summary of State Ethics Laws

18. Audit and Inspection of Plants, Places of Business and Records
19. Campaign Contribution Restriction
20. Tangible Personal Property
21. Bid Rigging and/or Fraud – Notice to Contractor
22. Consulting Agreement Affidavit
23. Federal Cargo Preference Act Requirements (46 CFR 381.7(a)-(b))

**Index of Exhibits**

- EXHIBIT A – FHWA Form 1273 (Begins on page 14)
- EXHIBIT B – Title VI Contractor Assurances (page 35)
- EXHIBIT C – Contractor Work Force Utilization (Federal Executive Order 11246) / Equal Employment Opportunity (page 36)
- EXHIBIT D – Health Insurance Portability and Accountability Act of 1996 (HIPAA) (page 43)
- EXHIBIT E - Campaign Contribution Restriction (page 51)
- EXHIBIT F – Federal Wage Rates (Attached at the end)
- EXHIBIT G - State Wage Rates (Attached at the end)

### **1. Federal Highway Administration (FHWA) Form 1273**

The Contractor shall comply with the Federal Highway Administration (FHWA), Form 1273 attached at Exhibit A, as revised, which is hereby made part of this contract. The Contractor shall also require its subcontractors to comply with the FHWA – Form 1273 and include the FHWA – Form 1273 as an attachment to all subcontracts and purchase orders.

### **2. Title VI of the Civil Rights Act of 1964 / Nondiscrimination Requirements**

The Contractor shall comply with Title VI of the Civil Rights Act of 1964 as amended (42 U.S.C. 2000 et seq.), all requirements imposed by the regulations of the United States Department of Transportation (49 CFR Part 21) issued in implementation thereof, and the Title VI Contractor Assurances attached hereto at Exhibit B, all of which are hereby made a part of this Contract.

### **3. Contractor Work Force Utilization (Federal Executive Order 11246) / Equal Employment Opportunity**

- (a) The Contractor shall comply with the Contractor Work Force Utilization (Federal Executive Order 11246) / Equal Employment Opportunity requirements attached at Exhibit C and hereby made part of this Contract, whenever a contractor or subcontractor at any tier performs construction work in excess of \$10,000. These goals shall be included in each contract and subcontract. Goal achievement is calculated for each trade using the hours worked under each trade.
- (b) Companies with contracts, agreements or purchase orders valued at \$10,000 or more will develop and implement an Affirmative Action Plan utilizing the ConnDOT Affirmative Action Plan Guideline. This Plan shall be designed to further the provision of equal employment opportunity to all persons without regard to their race, color, religion, sex or national origin, and to promote the full realization of equal employment opportunity through a positive continuation program. Plans shall be updated as required by ConnDOT.

### **4. Requirements of Title 49, Code of Federal Regulations (CFR), Part 26, Participation by DBEs**

Pursuant to 49 CFR 26.13, the following paragraph is part of this Contract and shall be included in each subcontract the Contractor enters into with a subcontractor:

“The Contractor, subrecipient or subcontractor shall not discriminate on the basis of race, color, national origin, or sex in the performance of this contract. The Contractor shall carry out applicable requirements of 49 CFR Part 26, Participation by DBEs, in the award and administration of U.S. DOT-assisted contracts. Failure by the Contractor to carry out these requirements is a material breach of this Contract, which may result in the termination of this contract or such other remedy as ConnDOT (recipient) deems appropriate.”

### **5. Contract Wage Rates**

The Contractor shall comply with:

The Federal and State wage rate requirements indicated in Exhibits F and G hereof, as revised, are hereby made part of this Contract. The Federal wage rates (Davis-Bacon Act) applicable to this Contract shall be the Federal wage rates that are current on the US Department of Labor website



(<http://www.wdol.gov/dba.aspx>) as may be revised 10 days prior to bid opening. These applicable Federal wage rates will be physically incorporated in the final contract document executed by both parties. The Department will no longer physically include revised Federal wage rates in the bid documents or as part of addenda documents, prior to the bid opening date. During the bid advertisement period, bidders are responsible for obtaining the appropriate Federal wage rates from the US Department of Labor website.

To obtain the latest Federal wage rates go to the US Department of Labor website (link above). Under Davis-Bacon Act, choose “Selecting DBA WDs” and follow the instruction to search the latest wage rates for the State, County and Construction Type. Refer to the Notice to Contractor (NTC) - Federal Wage Determinations (Davis Bacon Act).

If a conflict exists between the Federal and State wage rates, the higher rate shall govern.

Prevailing Wages for Work on State Highways; Annual Adjustments. With respect to contracts for work on state highways and bridges on state highways, the Contractor shall comply with the provisions of Section 31-54 and 31-55a of the Connecticut General Statutes, as revised.

As required by Section 1.05.12 (Payrolls) of the State of Connecticut, Department of Transportation’s Standard Specification for Roads, Bridges and Incidental Construction (FORM 816), as may be revised, every Contractor or subcontractor performing project work on a Federal aid project is required to post the relevant prevailing wage rates as determined by the United States Secretary of Labor. The wage rate determinations shall be posted in prominent and easily accessible places at the work site.

## **6. Americans with Disabilities Act of 1990, as Amended**

This provision applies to those Contractors who are or will be responsible for compliance with the terms of the Americans with Disabilities Act of 1990, as amended (42 U.S.C. 12101 et seq.), (Act), during the term of the Contract. The Contractor represents that it is familiar with the terms of this Act and that it is in compliance with the Act. Failure of the Contractor to satisfy this standard as the same applies to performance under this Contract, either now or during the term of the Contract as it may be amended, will render the Contract voidable at the option of the State upon notice to the contractor. The Contractor warrants that it will hold the State harmless and indemnify the State from any liability which may be imposed upon the State as a result of any failure of the Contractor to be in compliance with this Act, as the same applies to performance under this Contract.

## **7. Connecticut Statutory Labor Requirements**

**(a) Construction, Alteration or Repair of Public Works Projects; Wage Rates.** The Contractor shall comply with Section 31-53 of the Connecticut General Statutes, as revised. The wages paid on an hourly basis to any person performing the work of any mechanic, laborer or worker on the work herein contracted to be done and the amount of payment or contribution paid or payable on behalf of each such person to any employee welfare fund, as defined in subsection (i) of section 31-53 of the Connecticut General Statutes, shall be at a rate equal to the rate customary or prevailing for the same work in the same trade or occupation in the town in which such public works project is being constructed. Any contractor who is not obligated by agreement to make payment or contribution on behalf of such persons to any such employee welfare fund shall pay to each mechanic, laborer or worker as part of such person’s wages the amount of payment or contribution for such person’s classification on each pay day.

**(b) Debarment List. Limitation on Awarding Contracts.** The Contractor shall comply with Section 31-53a of the Connecticut General Statutes, as revised.

**(c) Construction Safety and Health Course.** The Contractor shall comply with section 31-53b of the Connecticut General Statutes, as revised. The contractor shall furnish proof to the Labor Commissioner with the weekly certified payroll form for the first week each employee begins work on such project that any person performing the work of a mechanic, laborer or worker pursuant to the classifications of labor under section 31-53 of the Connecticut General Statutes, as revised, on such public works project, pursuant to such contract, has completed a course of at least ten hours in duration in construction safety and health approved by the federal Occupational Safety and Health Administration or, has completed a new miner training program approved by the Federal Mine Safety and Health Administration in accordance with 30 CFR 48 or, in the case of telecommunications employees, has completed at least ten hours of training in accordance with 29 CFR 1910.268.

Any employee required to complete a construction safety and health course as required that has not completed the course, shall have a maximum of fourteen (14) days to complete the course. If the employee has not been brought into compliance, they shall be removed from the project until such time as they have completed the required training.

Any costs associated with this notice shall be included in the general cost of the contract. In addition, there shall be no time granted to the contractor for compliance with this notice. The contractor's compliance with this notice and any associated regulations shall not be grounds for claims as outlined in Section 1.11 – "Claims".

**(d) Awarding of Contracts to Occupational Safety and Health Law Violators Prohibited.** The Contract is subject to Section 31-57b of the Connecticut General Statutes, as revised.

**(e) Residents Preference in Work on Other Public Facilities. NOT APPLICABLE TO FEDERAL AID CONTRACTS.** Pursuant to Section 31-52a of the Connecticut General Statutes, as revised, in the employment of mechanics, laborers or workmen to perform the work specified herein, preference shall be given to residents of the state who are, and continuously for at least six months prior to the date hereof have been, residents of this state, and if no such person is available, then to residents of other states

## **8. Tax Liability - Contractor's Exempt Purchase Certificate (CERT – 141)**

The Contractor shall comply with Chapter 219 of the Connecticut General Statutes pertaining to tangible personal property or services rendered that is/are subject to sales tax. The Contractor is responsible for determining its tax liability. If the Contractor purchases materials or supplies pursuant to the Connecticut Department of Revenue Services' "Contractor's Exempt Purchase Certificate (CERT-141)," as may be revised, the Contractor acknowledges and agrees that title to such materials and supplies installed or placed in the project will vest in the State simultaneously with passage of title from the retailers or vendors thereof, and the Contractor will have no property rights in the materials and supplies purchased.

Forms and instructions are available anytime by:

Internet: Visit the DRS website at [www.ct.gov/DRS](http://www.ct.gov/DRS) to download and print Connecticut tax forms; or

Telephone: Call 1-800-382-9463 (Connecticut calls outside the Greater Hartford calling area only) and select Option 2 or call 860-297-4753 (from anywhere).

## 9. Executive Orders

This contract is subject to the provisions of Executive Order No. Three of Governor Thomas J. Meskill, promulgated June 16, 1971, concerning labor employment practices, Executive Order No. Seventeen of Governor Thomas J. Meskill, promulgated February 15, 1973, concerning the listing of employment openings and Executive Order No. Sixteen of Governor John G. Rowland promulgated August 4, 1999, concerning violence in the workplace, all of which are incorporated into and are made a part of the contract as if they had been fully set forth in it. The contract may also be subject to Executive Order No. 14 of Governor M. Jodi Rell, promulgated April 17, 2006, concerning procurement of cleaning products and services and to Executive Order No. 49 of Governor Dannel P. Malloy, promulgated May 22, 2015, mandating disclosure of certain gifts to public employees and contributions to certain candidates for office. If Executive Order No. 14 and/or Executive Order No. 49 are applicable, they are deemed to be incorporated into and are made a part of the contract as if they had been fully set forth in it. At the Contractor's request, the Department shall provide a copy of these orders to the Contractor.

## **10. Non Discrimination Requirement (pursuant to section 4a-60 and 4a-60a of the Connecticut General Statutes, as revised): References to "minority business enterprises" in this Section are not applicable to Federal-aid projects/contracts. Federal-aid projects/contracts are instead subject to the Federal Disadvantaged Business Enterprise Program.**

(a) For purposes of this Section, the following terms are defined as follows:

- i. "Commission" means the Commission on Human Rights and Opportunities;
- ii. "Contract" and "contract" include any extension or modification of the Contract or contract;
- iii. "Contractor" and "contractor" include any successors or assigns of the Contractor or contractor;
- iv. "gender identity or expression" means a person's gender-related identity, appearance or behavior, whether or not that gender-related identity, appearance or behavior is different from that traditionally associated with the person's physiology or assigned sex at birth, which gender-related identity can be shown by providing evidence including, but not limited to, medical history, care or treatment of the gender-related identity, consistent and uniform assertion of the gender-related identity or any other evidence that the gender-related identity is sincerely held, part of a person's core identity or not being asserted for an improper purpose.
- v. "good faith" means that degree of diligence which a reasonable person would exercise in the performance of legal duties and obligations;
- vi. "good faith efforts" shall include, but not be limited to, those reasonable initial efforts necessary to comply with statutory or regulatory requirements and additional or substituted efforts when it is determined that such initial efforts will not be sufficient to comply with such requirements;
- vii. "marital status" means being single, married as recognized by the State of Connecticut, widowed, separated or divorced;
- viii. "mental disability" means one or more mental disorders, as defined in the most recent edition of the American Psychiatric Association's "Diagnostic and Statistical Manual of Mental Disorders", or a record of or regarding a person as having one or more such disorders;

- ix. "minority business enterprise" means any small contractor or supplier of materials fifty-one percent or more of the capital stock, if any, or assets of which is owned by a person or persons: (1) who are active in the daily affairs of the enterprise, (2) who have the power to direct the management and policies of the enterprise, and (3) who are members of a minority, as such term is defined in subsection (a) of Connecticut General Statutes § 32-9n; and
- x. "public works contract" means any agreement between any individual, firm or corporation and the State or any political subdivision of the State other than a municipality for construction, rehabilitation, conversion, extension, demolition or repair of a public building, highway or other changes or improvements in real property, or which is financed in whole or in part by the State, including, but not limited to, matching expenditures, grants, loans, insurance or guarantees.

For purposes of this Section, the terms "Contract" and "contract" do not include a contract where each contractor is (1) a political subdivision of the State, including, but not limited to, a municipality, (2) a quasi-public agency, as defined in Conn. Gen. Stat. Section 1-120, (3) any other state, including but not limited to any federally recognized Indian tribal governments, as defined in Conn. Gen. Stat. Section 1-267, (4) the federal government, (5) a foreign government, or (6) an agency of a subdivision, agency, state or government described in the immediately preceding enumerated items (1), (2), (3), (4) or (5).

- (b) (1) The Contractor agrees and warrants that in the performance of the Contract such Contractor will not discriminate or permit discrimination against any person or group of persons on the grounds of race, color, religious creed, age, marital status, national origin, ancestry, sex, gender identity or expression, intellectual disability, mental disability or physical disability, including, but not limited to, blindness, unless it is shown by such Contractor that such disability prevents performance of the work involved, in any manner prohibited by the laws of the United States or of the State of Connecticut; and the Contractor further agrees to take affirmative action to insure that applicants with job-related qualifications are employed and that employees are treated when employed without regard to their race, color, religious creed, age, marital status, national origin, ancestry, sex, gender identity or expression, intellectual disability, mental disability or physical disability, including, but not limited to, blindness, unless it is shown by the Contractor that such disability prevents performance of the work involved; (2) the Contractor agrees, in all solicitations or advertisements for employees placed by or on behalf of the Contractor, to state that it is an "affirmative action-equal opportunity employer" in accordance with regulations adopted by the Commission; (3) the Contractor agrees to provide each labor union or representative of workers with which the Contractor has a collective bargaining Agreement or other contract or understanding and each vendor with which the Contractor has a contract or understanding, a notice to be provided by the Commission, advising the labor union or workers' representative of the Contractor's commitments under this section and to post copies of the notice in conspicuous places available to employees and applicants for employment; (4) the Contractor agrees to comply with each provision of this Section and Connecticut General Statutes §§ 46a-68e and 46a-68f and with each regulation or relevant order issued by said Commission pursuant to Connecticut General Statutes §§ 46a-56, 46a-68e and 46a-68f; and (5) the Contractor agrees to provide the Commission on Human Rights and Opportunities with such information requested by the Commission, and permit access to pertinent books, records and accounts, concerning the employment practices and procedures of the Contractor as relate to the provisions of this Section and Connecticut General Statutes § 46a-56. If the contract is a public works contract, the Contractor agrees and warrants that he will make good faith efforts to employ minority business enterprises as subcontractors and suppliers of materials on such public works projects.

- (c) Determination of the Contractor's good faith efforts shall include, but shall not be limited to, the following factors: The Contractor's employment and subcontracting policies, patterns and practices; affirmative advertising, recruitment and training; technical assistance activities and such other reasonable activities or efforts as the Commission may prescribe that are designed to ensure the participation of minority business enterprises in public works projects.
- (d) The Contractor shall develop and maintain adequate documentation, in a manner prescribed by the Commission, of its good faith efforts.
- (e) The Contractor shall include the provisions of subsection (b) of this Section in every subcontract or purchase order entered into in order to fulfill any obligation of a contract with the State and such provisions shall be binding on a subcontractor, vendor or manufacturer unless exempted by regulations or orders of the Commission. The Contractor shall take such action with respect to any such subcontract or purchase order as the Commission may direct as a means of enforcing such provisions including sanctions for noncompliance in accordance with Connecticut General Statutes §46a-56; provided if such Contractor becomes involved in, or is threatened with, litigation with a subcontractor or vendor as a result of such direction by the Commission, the Contractor may request the State of Connecticut to enter into any such litigation or negotiation prior thereto to protect the interests of the State and the State may so enter.
- (f) The Contractor agrees to comply with the regulations referred to in this Section as they exist on the date of this Contract and as they may be adopted or amended from time to time during the term of this Contract and any amendments thereto.
- (g) (1) The Contractor agrees and warrants that in the performance of the Contract such Contractor will not discriminate or permit discrimination against any person or group of persons on the grounds of sexual orientation, in any manner prohibited by the laws of the United States or the State of Connecticut, and that employees are treated when employed without regard to their sexual orientation; (2) the Contractor agrees to provide each labor union or representative of workers with which such Contractor has a collective bargaining Agreement or other contract or understanding and each vendor with which such Contractor has a contract or understanding, a notice to be provided by the Commission on Human Rights and Opportunities advising the labor union or workers' representative of the Contractor's commitments under this section, and to post copies of the notice in conspicuous places available to employees and applicants for employment; (3) the Contractor agrees to comply with each provision of this section and with each regulation or relevant order issued by said Commission pursuant to Connecticut General Statutes § 46a-56; and (4) the Contractor agrees to provide the Commission on Human Rights and Opportunities with such information requested by the Commission, and permit access to pertinent books, records and accounts, concerning the employment practices and procedures of the Contractor which relate to the provisions of this Section and Connecticut General Statutes § 46a-56.
- (h) The Contractor shall include the provisions of the foregoing paragraph in every subcontract or purchase order entered into in order to fulfill any obligation of a contract with the State and such provisions shall be binding on a subcontractor, vendor or manufacturer unless exempted by regulations or orders of the Commission. The Contractor shall take such action with respect to any such subcontract or purchase order as the Commission may direct as a means of enforcing such provisions including sanctions for noncompliance in accordance with Connecticut General Statutes § 46a-56; provided, if such Contractor becomes involved in, or is threatened with,

litigation with a subcontractor or vendor as a result of such direction by the Commission, the Contractor may request the State of Connecticut to enter into any such litigation or negotiation prior thereto to protect the interests of the State and the State may so enter.”

The Nondiscrimination Certifications can be found at the Office of Policy and Management website.

<http://www.ct.gov/opm/cwp/view.asp?a=2982&Q=390928>

## 11. Whistleblower Provision

The following clause is applicable if the Contract has a value of Five Million Dollars (\$5,000,000) or more.

**Whistleblowing.** This Contract may be subject to the provisions of Section 4-61dd of the Connecticut General Statutes. In accordance with this statute, if an officer, employee or appointing authority of the Contractor takes or threatens to take any personnel action against any employee of the Contractor in retaliation for such employee's disclosure of information to any employee of the contracting state or quasi-public agency or the Auditors of Public Accounts or the Attorney General under the provisions of subsection (a) of such statute, the Contractor shall be liable for a civil penalty of not more than five thousand dollars for each offense, up to a maximum of twenty per cent of the value of this Contract. Each violation shall be a separate and distinct offense and in the case of a continuing violation, each calendar day's continuance of the violation shall be deemed to be a separate and distinct offense. The State may request that the Attorney General bring a civil action in the Superior Court for the Judicial District of Hartford to seek imposition and recovery of such civil penalty. In accordance with subsection (f) of such statute, each large state contractor, as defined in the statute, shall post a notice of the provisions of the statute relating to large state contractors in a conspicuous place which is readily available for viewing by the employees of the Contractor.

## 12. Connecticut Freedom of Information Act

- (a) Disclosure of Records.** This Contract may be subject to the provisions of section 1-218 of the Connecticut General Statutes. In accordance with this statute, each contract in excess of two million five hundred thousand dollars between a public agency and a person for the performance of a governmental function shall (a) provide that the public agency is entitled to receive a copy of records and files related to the performance of the governmental function, and (b) indicate that such records and files are subject to FOIA and may be disclosed by the public agency pursuant to FOIA. No request to inspect or copy such records or files shall be valid unless the request is made to the public agency in accordance with FOIA. Any complaint by a person who is denied the right to inspect or copy such records or files shall be brought to the Freedom of Information Commission in accordance with the provisions of sections 1-205 and 1-206 of the Connecticut General Statutes.
- (b) Confidential Information.** The State will afford due regard to the Contractor's request for the protection of proprietary or confidential information which the State receives from the Contractor. However, all materials associated with the Contract are subject to the terms of the FOIA and all corresponding rules, regulations and interpretations. In making such a request, the Contractor may not merely state generally that the materials are proprietary or confidential in nature and not, therefore, subject to release to third parties. Those particular sentences, paragraphs, pages or sections that the Contractor believes are exempt from disclosure under the FOIA must be specifically identified as such. Convincing explanation and rationale sufficient to justify each exemption consistent with the FOIA must accompany the request. The rationale and explanation must be stated in terms of the prospective harm to the competitive position of the Contractor that would result if the identified material were to be released and the reasons why the materials are legally exempt

from release pursuant to the FOIA. To the extent that any other provision or part of the Contract conflicts or is in any way inconsistent with this section, this section controls and shall apply and the conflicting provision or part shall not be given effect. If the Contractor indicates that certain documentation is submitted in confidence, by specifically and clearly marking the documentation as “CONFIDENTIAL,” DOT will first review the Contractor’s claim for consistency with the FOIA (that is, review that the documentation is actually a trade secret or commercial or financial information and not required by statute), and if determined to be consistent, will endeavor to keep such information confidential to the extent permitted by law. See, *e.g.*, Conn. Gen. Stat. §1-210(b)(5)(A-B). The State, however, has no obligation to initiate, prosecute or defend any legal proceeding or to seek a protective order or other similar relief to prevent disclosure of any information that is sought pursuant to a FOIA request. Should the State withhold such documentation from a Freedom of Information requester and a complaint be brought to the Freedom of Information Commission, the Contractor shall have the burden of cooperating with DOT in defense of that action and in terms of establishing the availability of any FOIA exemption in any proceeding where it is an issue. In no event shall the State have any liability for the disclosure of any documents or information in its possession which the State believes are required to be disclosed pursuant to the FOIA or other law.

### **13. Service of Process**

The Contractor, if not a resident of the State of Connecticut, or, in the case of a partnership, the partners, if not residents, hereby appoints the Secretary of State of the State of Connecticut, and his successors in office, as agent for service of process for any action arising out of or as a result of this Contract; such appointment to be in effect throughout the life of this Contract and six (6) years thereafter.

### **14. Substitution of Securities for Retainages on State Contracts and Subcontracts**

This Contract is subject to the provisions of Section 3-112a of the General Statutes of the State of Connecticut, as revised.

### **15. Health Insurance Portability and Accountability Act of 1996 (HIPAA)**

The Contractor shall comply, if applicable, with the Health Insurance Portability and Accountability Act of 1996 and, pursuant thereto, the provisions attached at Exhibit D, and hereby made part of this Contract.

### **16. Forum and Choice of Law**

Forum and Choice of Law. The parties deem the Contract to have been made in the City of Hartford, State of Connecticut. Both parties agree that it is fair and reasonable for the validity and construction of the Contract to be, and it shall be, governed by the laws and court decisions of the State of Connecticut, without giving effect to its principles of conflicts of laws. To the extent that any immunities provided by Federal law or the laws of the State of Connecticut do not bar an action against the State, and to the extent that these courts are courts of competent jurisdiction, for the purpose of venue, the complaint shall be made returnable to the Judicial District of Hartford only or shall be brought in the United States District Court for the District of Connecticut only, and shall not be transferred to any other court, provided, however, that nothing here constitutes a waiver or compromise of the sovereign immunity of the State of Connecticut. The Contractor waives any objection which it may now have or will have to the laying of venue of any Claims in any forum and further irrevocably submits to such jurisdiction in any suit, action or proceeding.

## **17. Summary of State Ethics Laws**

Pursuant to the requirements of section 1-101qq of the Connecticut General Statutes, the summary of State ethics laws developed by the State Ethics Commission pursuant to section 1-81b of the Connecticut General Statutes is incorporated by reference into and made a part of the Contract as if the summary had been fully set forth in the Contract.

## **18. Audit and Inspection of Plants, Places of Business and Records**

- (a) The State and its agents, including, but not limited to, the Connecticut Auditors of Public Accounts, Attorney General and State's Attorney and their respective agents, may, at reasonable hours, inspect and examine all of the parts of the Contractor's and Contractor Parties' plants and places of business which, in any way, are related to, or involved in, the performance of this Contract. For the purposes of this Section, "Contractor Parties" means the Contractor's members, directors, officers, shareholders, partners, managers, principal officers, representatives, agents, servants, consultants, employees or any one of them or any other person or entity with whom the Contractor is in privity of oral or written contract and the Contractor intends for such other person or entity to Perform under the Contract in any capacity.
- (b) The Contractor shall maintain, and shall require each of the Contractor Parties to maintain, accurate and complete Records. The Contractor shall make all of its and the Contractor Parties' Records available at all reasonable hours for audit and inspection by the State and its agents.
- (c) The State shall make all requests for any audit or inspection in writing and shall provide the Contractor with at least twenty-four (24) hours' notice prior to the requested audit and inspection date. If the State suspects fraud or other abuse, or in the event of an emergency, the State is not obligated to provide any prior notice.
- (d) The Contractor shall keep and preserve or cause to be kept and preserved all of its and Contractor Parties' Records until three (3) years after the latter of (i) final payment under this Agreement, or (ii) the expiration or earlier termination of this Agreement, as the same may be modified for any reason. The State may request an audit or inspection at any time during this period. If any Claim or audit is started before the expiration of this period, the Contractor shall retain or cause to be retained all Records until all Claims or audit findings have been resolved.
- (e) The Contractor shall cooperate fully with the State and its agents in connection with an audit or inspection. Following any audit or inspection, the State may conduct and the Contractor shall cooperate with an exit conference.
- (f) The Contractor shall incorporate this entire Section verbatim into any contract or other agreement that it enters into with any Contractor Party.

## **19. Campaign Contribution Restriction**

For all State contracts, defined in Conn. Gen. Stat. §9-612(f)(1) as having a value in a calendar year of \$50,000 or more, or a combination or series of such agreements or contracts having a value of \$100,000 or more, the authorized signatory to this contract expressly acknowledges receipt of the State Elections Enforcement Commission's notice advising state contractors of state campaign contribution and solicitation prohibitions, and will inform its principals of the contents of the notice, as set forth in "Notice to Executive Branch State Contractors and Prospective State Contractors of Campaign Contribution and Solicitation Limitations," a copy of which is attached hereto and hereby made a part of this contract, attached as Exhibit E.

## **20. Tangible Personal Property**

- (a) The Contractor on its behalf and on behalf of its Affiliates, as defined below, shall comply with the provisions of Conn. Gen. Stat. §12-411b, as follows:



- (1) For the term of the Contract, the Contractor and its Affiliates shall collect and remit to the State of Connecticut, Department of Revenue Services, any Connecticut use tax due under the provisions of Chapter 219 of the Connecticut General Statutes for items of tangible personal property sold by the Contractor or by any of its Affiliates in the same manner as if the Contractor and such Affiliates were engaged in the business of selling tangible personal property for use in Connecticut and had sufficient nexus under the provisions of Chapter 219 to be required to collect Connecticut use tax;
  - (2) A customer's payment of a use tax to the Contractor or its Affiliates relieves the customer of liability for the use tax;
  - (3) The Contractor and its Affiliates shall remit all use taxes they collect from customers on or before the due date specified in the Contract, which may not be later than the last day of the month next succeeding the end of a calendar quarter or other tax collection period during which the tax was collected;
  - (4) The Contractor and its Affiliates are not liable for use tax billed by them but not paid to them by a customer; and
  - (5) Any Contractor or Affiliate who fails to remit use taxes collected on behalf of its customers by the due date specified in the Contract shall be subject to the interest and penalties provided for persons required to collect sales tax under chapter 219 of the general statutes.
- (b) For purposes of this section of the Contract, the word "Affiliate" means any person, as defined in section 12-1 of the general statutes, that controls, is controlled by, or is under common control with another person. A person controls another person if the person owns, directly or indirectly, more than ten per cent of the voting securities of the other person. The word "voting security" means a security that confers upon the holder the right to vote for the election of members of the board of directors or similar governing body of the business, or that is convertible into, or entitles the holder to receive, upon its exercise, a security that confers such a right to vote. "Voting security" includes a general partnership interest.
- (c) The Contractor represents and warrants that each of its Affiliates has vested in the Contractor plenary authority to so bind the Affiliates in any agreement with the State of Connecticut. The Contractor on its own behalf and on behalf of its Affiliates shall also provide, no later than 30 days after receiving a request by the State's contracting authority, such information as the State may require to ensure, in the State's sole determination, compliance with the provisions of Chapter 219 of the Connecticut General Statutes, including, but not limited to, §12-411b.

## **21. Bid Rigging and/or Fraud – Notice to Contractor**

The Connecticut Department of Transportation is cooperating with the U.S. Department of Transportation and the Justice Department in their investigation into highway construction contract bid rigging and/or fraud.

A toll-free "HOT LINE" telephone number 800-424-9071 has been established to receive information from contractors, subcontractors, manufacturers, suppliers or anyone with knowledge of bid rigging and/or fraud, either past or current. The "HOT LINE" telephone number will be available during normal working hours (8:00 am – 5:00 pm EST). Information will be treated confidentially and anonymity respected.

## **22. Consulting Agreement Affidavit**

The Contractor shall comply with Connecticut General Statutes Section 4a-81(a) and 4a-81(b), as revised. Pursuant to Public Act 11-229, after the initial submission of the form, if there is a change in the information contained in the form, a contractor shall submit the updated form, as applicable, either (i) not later than thirty (30) days after the effective date of such change or (ii) prior to execution of any new contract, whichever is earlier.

The Affidavit/Form may be submitted in written format or electronic format through the Department of Administrative Services (DAS) website.

### **23. Cargo Preference Act Requirements (46 CFR 381.7(a)-(b)) – Use of United States Flag Vessels**

The Contractor agrees to comply with the following:

(a) ***Agreement Clauses.***

- (1) Pursuant to Pub. L. 664 ([43 U.S.C. 1241\(b\)](#)) at least 50 percent of any equipment, materials or commodities procured, contracted for or otherwise obtained with funds granted, guaranteed, loaned, or advanced by the U.S. Government under this agreement, and which may be transported by ocean vessel, shall be transported on privately owned United States-flag commercial vessels, if available.
- (2) Within 20 days following the date of loading for shipments originating within the United States or within 30 working days following the date of loading for shipments originating outside the United States, a legible copy of a rated, ‘on-board’ commercial ocean bill-of-lading in English for each shipment of cargo described in paragraph (a)(1) of this section shall be furnished to both the Contracting Officer (through the prime contractor in the case of subcontractor bills-of-lading) and to the Division of National Cargo, Office of Market Development, Maritime Administration, Washington, DC 20590.

(b) ***Contractor and Subcontractor Clauses.*** The contractor agrees—

- (1) To utilize privately owned United States-flag commercial vessels to ship at least 50 percent of the gross tonnage (computed separately for dry bulk carriers, dry cargo liners, and tankers) involved, whenever shipping any equipment, material, or commodities pursuant to this contract, to the extent such vessels are available at fair and reasonable rates for United States-flag commercial vessels.
- (2) To furnish within 20 days following the date of loading for shipments originating within the United States or within 30 working days following the date of loading for shipments originating outside the United States, a legible copy of a rated, ‘on-board’ commercial ocean bill-of-lading in English for each shipment of cargo described in paragraph (b) (1) of this section to both the Contracting Officer (through the prime contractor in the case of subcontractor bills-of-lading) and to the Division of National Cargo, Office of Market Development, Maritime Administration, Washington, DC 20590.
- (3) To insert the substance of the provisions of this clause in all subcontracts issued pursuant to this contract.

## EXHIBIT A

FHWA-1273 -- Revised May 1, 2012

### REQUIRED CONTRACT PROVISIONS FEDERAL-AID CONSTRUCTION CONTRACTS

- I. General
- II. Nondiscrimination
- III. Nonsegregated Facilities
- IV. Davis-Bacon and Related Act Provisions
- V. Contract Work Hours and Safety Standards Act Provisions
- VI. Subletting or Assigning the Contract
- VII. Safety: Accident Prevention
- VIII. False Statements Concerning Highway Projects
- IX. Implementation of Clean Air Act and Federal Water Pollution Control Act
- X. Compliance with Governmentwide Suspension and Debarment Requirements
- XI. Certification Regarding Use of Contract Funds for Lobbying

### ATTACHMENTS

A. Employment and Materials Preference for Appalachian Development Highway System or Appalachian Local Access Road Contracts (included in Appalachian contracts only)

#### I. GENERAL

1. Form FHWA-1273 must be physically incorporated in each construction contract funded under Title 23 (excluding emergency contracts solely intended for debris removal). The contractor (or subcontractor) must insert this form in each subcontract and further require its inclusion in all lower tier subcontracts (excluding purchase orders, rental agreements and other agreements for supplies or services).

The applicable requirements of Form FHWA-1273 are incorporated by reference for work done under any purchase order, rental agreement or agreement for other services. The prime contractor shall be responsible for compliance by any subcontractor, lower-tier subcontractor or service provider.

Form FHWA-1273 must be included in all Federal-aid design-build contracts, in all subcontracts and in lower tier subcontracts (excluding subcontracts for design services, purchase orders, rental agreements and other agreements for supplies or services). The design-builder shall be responsible for compliance by any subcontractor, lower-tier subcontractor or service provider.

Contracting agencies may reference Form FHWA-1273 in bid proposal or request for proposal documents, however, the Form FHWA-1273 must be physically incorporated (not referenced) in all contracts, subcontracts and lower-tier subcontracts (excluding purchase orders, rental agreements and other agreements for supplies or services related to a construction contract).

2. Subject to the applicability criteria noted in the following sections, these contract provisions shall apply to all work performed on the contract by the contractor's own organization and with the

assistance of workers under the contractor's immediate superintendence and to all work performed on the contract by piecework, station work, or by subcontract.

3. A breach of any of the stipulations contained in these Required Contract Provisions may be sufficient grounds for withholding of progress payments, withholding of final payment, termination of the contract, suspension / debarment or any other action determined to be appropriate by the contracting agency and FHWA.

4. Selection of Labor: During the performance of this contract, the contractor shall not use convict labor for any purpose within the limits of a construction project on a Federal-aid highway unless it is labor performed by convicts who are on parole, supervised release, or probation. The term Federal-aid highway does not include roadways functionally classified as local roads or rural minor collectors.

## II. NONDISCRIMINATION

The provisions of this section related to 23 CFR Part 230 are applicable to all Federal-aid construction contracts and to all related construction subcontracts of \$10,000 or more. The provisions of 23 CFR Part 230 are not applicable to material supply, engineering, or architectural service contracts.

In addition, the contractor and all subcontractors must comply with the following policies: Executive Order 11246, 41 CFR 60, 29 CFR 1625-1627, Title 23 USC Section 140, the Rehabilitation Act of 1973, as amended (29 USC 794), Title VI of the Civil Rights Act of 1964, as amended, and related regulations including 49 CFR Parts 21, 26 and 27; and 23 CFR Parts 200, 230, and 633.

The contractor and all subcontractors must comply with: the requirements of the Equal Opportunity Clause in 41 CFR 60-1.4(b) and, for all construction contracts exceeding \$10,000, the Standard Federal Equal Employment Opportunity Construction Contract Specifications in 41 CFR 60-4.3.

Note: The U.S. Department of Labor has exclusive authority to determine compliance with Executive Order 11246 and the policies of the Secretary of Labor including 41 CFR 60, and 29 CFR 1625-1627. The contracting agency and the FHWA have the authority and the responsibility to ensure compliance with Title 23 USC Section 140, the Rehabilitation Act of 1973, as amended (29 USC 794), and Title VI of the Civil Rights Act of 1964, as amended, and related regulations including 49 CFR Parts 21, 26 and 27; and 23 CFR Parts 200, 230, and 633.

The following provision is adopted from 23 CFR 230, Appendix A, with appropriate revisions to conform to the U.S. Department of Labor (US DOL) and FHWA requirements.

**1. Equal Employment Opportunity:** Equal employment opportunity (EEO) requirements not to discriminate and to take affirmative action to assure equal opportunity as set forth under laws, executive orders, rules, regulations (28 CFR 35, 29 CFR 1630, 29 CFR 1625-1627, 41 CFR 60 and 49 CFR 27) and orders of the Secretary of Labor as modified by the provisions prescribed herein, and imposed pursuant to 23 U.S.C. 140 shall constitute the EEO and specific affirmative action standards for the contractor's project activities under this contract. The provisions of the Americans with Disabilities Act of 1990 (42 U.S.C. 12101 et seq.) set forth under 28 CFR 35 and 29 CFR 1630 are incorporated by reference in this contract. In the execution of this contract, the contractor agrees to comply with the following minimum specific requirement activities of EEO:

a. The contractor will work with the contracting agency and the Federal Government to ensure that it has made every good faith effort to provide equal opportunity with respect to all of its terms and conditions of employment and in their review of activities under the contract.

b. The contractor will accept as its operating policy the following statement:

"It is the policy of this Company to assure that applicants are employed, and that employees are treated during employment, without regard to their race, religion, sex, color, national origin, age or disability. Such action shall include: employment, upgrading, demotion, or transfer; recruitment or recruitment advertising; layoff or termination; rates of pay or other forms of compensation; and selection for training, including apprenticeship, pre-apprenticeship, and/or on-the-job training."

**2. EEO Officer:** The contractor will designate and make known to the contracting officers an EEO Officer who will have the responsibility for and must be capable of effectively administering and promoting an active EEO program and who must be assigned adequate authority and responsibility to do so.

**3. Dissemination of Policy:** All members of the contractor's staff who are authorized to hire, supervise, promote, and discharge employees, or who recommend such action, or who are substantially involved in such action, will be made fully cognizant of, and will implement, the contractor's EEO policy and contractual responsibilities to provide EEO in each grade and classification of employment. To ensure that the above agreement will be met, the following actions will be taken as a minimum:

a. Periodic meetings of supervisory and personnel office employees will be conducted before the start of work and then not less often than once every six months, at which time the contractor's EEO policy and its implementation will be reviewed and explained. The meetings will be conducted by the EEO Officer.

b. All new supervisory or personnel office employees will be given a thorough indoctrination by the EEO Officer, covering all major aspects of the contractor's EEO obligations within thirty days following their reporting for duty with the contractor.

c. All personnel who are engaged in direct recruitment for the project will be instructed by the EEO Officer in the contractor's procedures for locating and hiring minorities and women.

d. Notices and posters setting forth the contractor's EEO policy will be placed in areas readily accessible to employees, applicants for employment and potential employees.

e. The contractor's EEO policy and the procedures to implement such policy will be brought to the attention of employees by means of meetings, employee handbooks, or other appropriate means.

**4. Recruitment:** When advertising for employees, the contractor will include in all advertisements for employees the notation: "An Equal Opportunity Employer." All such advertisements will be placed in publications having a large circulation among minorities and women in the area from which the project work force would normally be derived.

a. The contractor will, unless precluded by a valid bargaining agreement, conduct systematic and direct recruitment through public and private employee referral sources likely to yield qualified minorities and women. To meet this requirement, the contractor will identify sources of potential

minority group employees, and establish with such identified sources procedures whereby minority and women applicants may be referred to the contractor for employment consideration.

b. In the event the contractor has a valid bargaining agreement providing for exclusive hiring hall referrals, the contractor is expected to observe the provisions of that agreement to the extent that the system meets the contractor's compliance with EEO contract provisions. Where implementation of such an agreement has the effect of discriminating against minorities or women, or obligates the contractor to do the same, such implementation violates Federal nondiscrimination provisions.

c. The contractor will encourage its present employees to refer minorities and women as applicants for employment. Information and procedures with regard to referring such applicants will be discussed with employees.

**5. Personnel Actions:** Wages, working conditions, and employee benefits shall be established and administered, and personnel actions of every type, including hiring, upgrading, promotion, transfer, demotion, layoff, and termination, shall be taken without regard to race, color, religion, sex, national origin, age or disability. The following procedures shall be followed:

a. The contractor will conduct periodic inspections of project sites to insure that working conditions and employee facilities do not indicate discriminatory treatment of project site personnel.

b. The contractor will periodically evaluate the spread of wages paid within each classification to determine any evidence of discriminatory wage practices.

c. The contractor will periodically review selected personnel actions in depth to determine whether there is evidence of discrimination. Where evidence is found, the contractor will promptly take corrective action. If the review indicates that the discrimination may extend beyond the actions reviewed, such corrective action shall include all affected persons.

d. The contractor will promptly investigate all complaints of alleged discrimination made to the contractor in connection with its obligations under this contract, will attempt to resolve such complaints, and will take appropriate corrective action within a reasonable time. If the investigation indicates that the discrimination may affect persons other than the complainant, such corrective action shall include such other persons. Upon completion of each investigation, the contractor will inform every complainant of all of their avenues of appeal.

## **6. Training and Promotion:**

a. The contractor will assist in locating, qualifying, and increasing the skills of minorities and women who are applicants for employment or current employees. Such efforts should be aimed at developing full journey level status employees in the type of trade or job classification involved.

b. Consistent with the contractor's work force requirements and as permissible under Federal and State regulations, the contractor shall make full use of training programs, i.e., apprenticeship, and on-the-job training programs for the geographical area of contract performance. In the event a special provision for training is provided under this contract, this subparagraph will be superseded as indicated in the special provision. The contracting agency may reserve training positions for persons who receive welfare assistance in accordance with 23 U.S.C. 140(a).

c. The contractor will advise employees and applicants for employment of available training programs and entrance requirements for each.

d. The contractor will periodically review the training and promotion potential of employees who are minorities and women and will encourage eligible employees to apply for such training and promotion.

**7. Unions:** If the contractor relies in whole or in part upon unions as a source of employees, the contractor will use good faith efforts to obtain the cooperation of such unions to increase opportunities for minorities and women. Actions by the contractor, either directly or through a contractor's association acting as agent, will include the procedures set forth below:

a. The contractor will use good faith efforts to develop, in cooperation with the unions, joint training programs aimed toward qualifying more minorities and women for membership in the unions and increasing the skills of minorities and women so that they may qualify for higher paying employment.

b. The contractor will use good faith efforts to incorporate an EEO clause into each union agreement to the end that such union will be contractually bound to refer applicants without regard to their race, color, religion, sex, national origin, age or disability.

c. The contractor is to obtain information as to the referral practices and policies of the labor union except that to the extent such information is within the exclusive possession of the labor union and such labor union refuses to furnish such information to the contractor, the contractor shall so certify to the contracting agency and shall set forth what efforts have been made to obtain such information.

d. In the event the union is unable to provide the contractor with a reasonable flow of referrals within the time limit set forth in the collective bargaining agreement, the contractor will, through independent recruitment efforts, fill the employment vacancies without regard to race, color, religion, sex, national origin, age or disability; making full efforts to obtain qualified and/or qualifiable minorities and women. The failure of a union to provide sufficient referrals (even though it is obligated to provide exclusive referrals under the terms of a collective bargaining agreement) does not relieve the contractor from the requirements of this paragraph. In the event the union referral practice prevents the contractor from meeting the obligations pursuant to Executive Order 11246, as amended, and these special provisions, such contractor shall immediately notify the contracting agency.

**8. Reasonable Accommodation for Applicants / Employees with Disabilities:** The contractor must be familiar with the requirements for and comply with the Americans with Disabilities Act and all rules and regulations established there under. Employers must provide reasonable accommodation in all employment activities unless to do so would cause an undue hardship.

**9. Selection of Subcontractors, Procurement of Materials and Leasing of Equipment:** The contractor shall not discriminate on the grounds of race, color, religion, sex, national origin, age or disability in the selection and retention of subcontractors, including procurement of materials and leases of equipment. The contractor shall take all necessary and reasonable steps to ensure nondiscrimination in the administration of this contract.

a. The contractor shall notify all potential subcontractors and suppliers and lessors of their EEO obligations under this contract.

b. The contractor will use good faith efforts to ensure subcontractor compliance with their EEO obligations.

**10. Assurance Required by 49 CFR 26.13(b):**

a. The requirements of 49 CFR Part 26, and the State DOT's U.S. DOT-approved DBE program are incorporated by reference.

b. The contractor or subcontractor shall not discriminate on the basis of race, color, national origin, or sex in the performance of this contract. The contractor shall carry out applicable requirements of 49 CFR Part 26, in the award and administration of DOT-assisted contracts. Failure by the contractor to carry out these requirements is a material breach of this contract, which may result in the termination of this contract or such other remedy as the contracting agency deems appropriate.

**11. Records and Reports:** The contractor shall keep such records as necessary to document compliance with the EEO requirements. Such records shall be retained for a period of three years following the date of the final payment to the contractor for all contract work and shall be available at reasonable times and places for inspection by authorized representatives of the contracting agency and the FHWA.

a. The records kept by the contractor shall document the following:

(1) The number and work hours of minority and non-minority group members and women employed in each work classification on the project;

(2) The progress and efforts being made in cooperation with unions, when applicable, to increase employment opportunities for minorities and women; and

(3) The progress and efforts being made in locating, hiring, training, qualifying, and upgrading minorities and women;

b. The contractors and subcontractors will submit an annual report to the contracting agency each July for the duration of the project, indicating the number of minority, women, and non-minority group employees currently engaged in each work classification required by the contract work. This information is to be reported on [Form FHWA-1391](#). The staffing data should represent the project work force on board in all or any part of the last payroll period preceding the end of July. If on-the-job training is being required by special provision, the contractor will be required to collect and report training data. The employment data should reflect the work force on board during all or any part of the last payroll period preceding the end of July.

**III. NONSEGREGATED FACILITIES**

This provision is applicable to all Federal-aid construction contracts and to all related construction subcontracts of \$10,000 or more.

The contractor must ensure that facilities provided for employees are provided in such a manner that segregation on the basis of race, color, religion, sex, or national origin cannot result. The contractor may neither require such segregated use by written or oral policies nor tolerate such use by employee custom. The contractor's obligation extends further to ensure that its employees are not assigned to perform their services at any location, under the contractor's control, where the facilities are segregated. The term "facilities" includes waiting rooms, work areas, restaurants and other eating



areas, time clocks, restrooms, washrooms, locker rooms, and other storage or dressing areas, parking lots, drinking fountains, recreation or entertainment areas, transportation, and housing provided for employees. The contractor shall provide separate or single-user restrooms and necessary dressing or sleeping areas to assure privacy between sexes.

#### **IV. DAVIS-BACON AND RELATED ACT PROVISIONS**

This section is applicable to all Federal-aid construction projects exceeding \$2,000 and to all related subcontracts and lower-tier subcontracts (regardless of subcontract size). The requirements apply to all projects located within the right-of-way of a roadway that is functionally classified as Federal-aid highway. This excludes roadways functionally classified as local roads or rural minor collectors, which are exempt. Contracting agencies may elect to apply these requirements to other projects.

The following provisions are from the U.S. Department of Labor regulations in 29 CFR 5.5 “Contract provisions and related matters” with minor revisions to conform to the FHWA-1273 format and FHWA program requirements.

##### **1. Minimum wages**

a. All laborers and mechanics employed or working upon the site of the work, will be paid unconditionally and not less often than once a week, and without subsequent deduction or rebate on any account (except such payroll deductions as are permitted by regulations issued by the Secretary of Labor under the Copeland Act (29 CFR part 3)), the full amount of wages and bona fide fringe benefits (or cash equivalents thereof) due at time of payment computed at rates not less than those contained in the wage determination of the Secretary of Labor which is attached hereto and made a part hereof, regardless of any contractual relationship which may be alleged to exist between the contractor and such laborers and mechanics.

Contributions made or costs reasonably anticipated for bona fide fringe benefits under section 1(b)(2) of the Davis-Bacon Act on behalf of laborers or mechanics are considered wages paid to such laborers or mechanics, subject to the provisions of paragraph 1.d. of this section; also, regular contributions made or costs incurred for more than a weekly period (but not less often than quarterly) under plans, funds, or programs which cover the particular weekly period, are deemed to be constructively made or incurred during such weekly period. Such laborers and mechanics shall be paid the appropriate wage rate and fringe benefits on the wage determination for the classification of work actually performed, without regard to skill, except as provided in 29 CFR 5.5(a)(4). Laborers or mechanics performing work in more than one classification may be compensated at the rate specified for each classification for the time actually worked therein: Provided, That the employer's payroll records accurately set forth the time spent in each classification in which work is performed. The wage determination (including any additional classification and wage rates conformed under paragraph 1.b. of this section) and the Davis-Bacon poster (WH-1321) shall be posted at all times by the contractor and its subcontractors at the site of the work in a prominent and accessible place where it can be easily seen by the workers.

b. (1) The contracting officer shall require that any class of laborers or mechanics, including helpers, which is not listed in the wage determination and which is to be employed under the contract shall be classified in conformance with the wage determination. The contracting officer shall approve an additional classification and wage rate and fringe benefits therefore only when the following criteria have been met:

- (i) The work to be performed by the classification requested is not performed by a classification in the wage determination; and
- (ii) The classification is utilized in the area by the construction industry; and
- (iii) The proposed wage rate, including any bona fide fringe benefits, bears a reasonable relationship to the wage rates contained in the wage determination.

(2) If the contractor and the laborers and mechanics to be employed in the classification (if known), or their representatives, and the contracting officer agree on the classification and wage rate (including the amount designated for fringe benefits where appropriate), a report of the action taken shall be sent by the contracting officer to the Administrator of the Wage and Hour Division, Employment Standards Administration, U.S. Department of Labor, Washington, DC 20210. The Administrator, or an authorized representative, will approve, modify, or disapprove every additional classification action within 30 days of receipt and so advise the contracting officer or will notify the contracting officer within the 30-day period that additional time is necessary.

(3) In the event the contractor, the laborers or mechanics to be employed in the classification or their representatives, and the contracting officer do not agree on the proposed classification and wage rate (including the amount designated for fringe benefits, where appropriate), the contracting officer shall refer the questions, including the views of all interested parties and the recommendation of the contracting officer, to the Wage and Hour Administrator for determination. The Wage and Hour Administrator, or an authorized representative, will issue a determination within 30 days of receipt and so advise the contracting officer or will notify the contracting officer within the 30-day period that additional time is necessary.

(4) The wage rate (including fringe benefits where appropriate) determined pursuant to paragraphs 1.b.(2) or 1.b.(3) of this section, shall be paid to all workers performing work in the classification under this contract from the first day on which work is performed in the classification.

c. Whenever the minimum wage rate prescribed in the contract for a class of laborers or mechanics includes a fringe benefit which is not expressed as an hourly rate, the contractor shall either pay the benefit as stated in the wage determination or shall pay another bona fide fringe benefit or an hourly cash equivalent thereof.

d. If the contractor does not make payments to a trustee or other third person, the contractor may consider as part of the wages of any laborer or mechanic the amount of any costs reasonably anticipated in providing bona fide fringe benefits under a plan or program, Provided, That the Secretary of Labor has found, upon the written request of the contractor, that the applicable standards of the Davis-Bacon Act have been met. The Secretary of Labor may require the contractor to set aside in a separate account assets for the meeting of obligations under the plan or program.

## **2. Withholding**

The contracting agency shall upon its own action or upon written request of an authorized representative of the Department of Labor, withhold or cause to be withheld from the contractor under this contract, or any other Federal contract with the same prime contractor, or any other federally-assisted contract subject to Davis-Bacon prevailing wage requirements, which is held by the same prime contractor, so much of the accrued payments or advances as may be considered necessary to pay laborers and mechanics, including apprentices, trainees, and helpers, employed by the contractor or

any subcontractor the full amount of wages required by the contract. In the event of failure to pay any laborer or mechanic, including any apprentice, trainee, or helper, employed or working on the site of the work, all or part of the wages required by the contract, the contracting agency may, after written notice to the contractor, take such action as may be necessary to cause the suspension of any further payment, advance, or guarantee of funds until such violations have ceased.

### **3. Payrolls and basic records**

a. Payrolls and basic records relating thereto shall be maintained by the contractor during the course of the work and preserved for a period of three years thereafter for all laborers and mechanics working at the site of the work. Such records shall contain the name, address, and social security number of each such worker, his or her correct classification, hourly rates of wages paid (including rates of contributions or costs anticipated for bona fide fringe benefits or cash equivalents thereof of the types described in section 1(b)(2)(B) of the Davis-Bacon Act), daily and weekly number of hours worked, deductions made and actual wages paid. Whenever the Secretary of Labor has found under 29 CFR 5.5(a)(1)(iv) that the wages of any laborer or mechanic include the amount of any costs reasonably anticipated in providing benefits under a plan or program described in section 1(b)(2)(B) of the Davis-Bacon Act, the contractor shall maintain records which show that the commitment to provide such benefits is enforceable, that the plan or program is financially responsible, and that the plan or program has been communicated in writing to the laborers or mechanics affected, and records which show the costs anticipated or the actual cost incurred in providing such benefits. Contractors employing apprentices or trainees under approved programs shall maintain written evidence of the registration of apprenticeship programs and certification of trainee programs, the registration of the apprentices and trainees, and the ratios and wage rates prescribed in the applicable programs.

b. (1) The contractor shall submit weekly for each week in which any contract work is performed a copy of all payrolls to the contracting agency. The payrolls submitted shall set out accurately and completely all of the information required to be maintained under 29 CFR 5.5(a)(3)(i), except that full social security numbers and home addresses shall not be included on weekly transmittals. Instead the payrolls shall only need to include an individually identifying number for each employee ( e.g. , the last four digits of the employee's social security number). The required weekly payroll information may be submitted in any form desired. Optional Form WH-347 is available for this purpose from the Wage and Hour Division Web site at <http://www.dol.gov/esa/whd/forms/wh347instr.htm> or its successor site. The prime contractor is responsible for the submission of copies of payrolls by all subcontractors. Contractors and subcontractors shall maintain the full social security number and current address of each covered worker, and shall provide them upon request to the contracting agency for transmission to the State DOT, the FHWA or the Wage and Hour Division of the Department of Labor for purposes of an investigation or audit of compliance with prevailing wage requirements. It is not a violation of this section for a prime contractor to require a subcontractor to provide addresses and social security numbers to the prime contractor for its own records, without weekly submission to the contracting agency..

(2) Each payroll submitted shall be accompanied by a “Statement of Compliance,” signed by the contractor or subcontractor or his or her agent who pays or supervises the payment of the persons employed under the contract and shall certify the following:

(i) That the payroll for the payroll period contains the information required to be provided under §5.5 (a)(3)(ii) of Regulations, 29 CFR part 5, the appropriate information is being maintained under §5.5 (a)(3)(i) of Regulations, 29 CFR part 5, and that such information is correct and complete;

(ii) That each laborer or mechanic (including each helper, apprentice, and trainee) employed on the contract during the payroll period has been paid the full weekly wages earned, without rebate, either directly or indirectly, and that no deductions have been made either directly or indirectly from the full wages earned, other than permissible deductions as set forth in Regulations, 29 CFR part 3;

(iii) That each laborer or mechanic has been paid not less than the applicable wage rates and fringe benefits or cash equivalents for the classification of work performed, as specified in the applicable wage determination incorporated into the contract.

(3) The weekly submission of a properly executed certification set forth on the reverse side of Optional Form WH-347 shall satisfy the requirement for submission of the "Statement of Compliance" required by paragraph 3.b.(2) of this section.

(4) The falsification of any of the above certifications may subject the contractor or subcontractor to civil or criminal prosecution under section 1001 of title 18 and section 231 of title 31 of the United States Code.

c. The contractor or subcontractor shall make the records required under paragraph 3.a. of this section available for inspection, copying, or transcription by authorized representatives of the contracting agency, the State DOT, the FHWA, or the Department of Labor, and shall permit such representatives to interview employees during working hours on the job. If the contractor or subcontractor fails to submit the required records or to make them available, the FHWA may, after written notice to the contractor, the contracting agency or the State DOT, take such action as may be necessary to cause the suspension of any further payment, advance, or guarantee of funds. Furthermore, failure to submit the required records upon request or to make such records available may be grounds for debarment action pursuant to 29 CFR 5.12.

#### **4. Apprentices and trainees**

a. Apprentices (programs of the USDOL).

Apprentices will be permitted to work at less than the predetermined rate for the work they performed when they are employed pursuant to and individually registered in a bona fide apprenticeship program registered with the U.S. Department of Labor, Employment and Training Administration, Office of Apprenticeship Training, Employer and Labor Services, or with a State Apprenticeship Agency recognized by the Office, or if a person is employed in his or her first 90 days of probationary employment as an apprentice in such an apprenticeship program, who is not individually registered in the program, but who has been certified by the Office of Apprenticeship Training, Employer and Labor Services or a State Apprenticeship Agency (where appropriate) to be eligible for probationary employment as an apprentice.

The allowable ratio of apprentices to journeymen on the job site in any craft classification shall not be greater than the ratio permitted to the contractor as to the entire work force under the registered program. Any worker listed on a payroll at an apprentice wage rate, who is not registered or otherwise employed as stated above, shall be paid not less than the applicable wage rate on the wage determination for the classification of work actually performed. In addition, any apprentice performing work on the job site in excess of the ratio permitted under the registered program shall be paid not less than the applicable wage rate on the wage determination for the work actually performed. Where a contractor is performing construction on a project in a locality other than that in which its program is

registered, the ratios and wage rates (expressed in percentages of the journeyman's hourly rate) specified in the contractor's or subcontractor's registered program shall be observed.

Every apprentice must be paid at not less than the rate specified in the registered program for the apprentice's level of progress, expressed as a percentage of the journeymen hourly rate specified in the applicable wage determination. Apprentices shall be paid fringe benefits in accordance with the provisions of the apprenticeship program. If the apprenticeship program does not specify fringe benefits, apprentices must be paid the full amount of fringe benefits listed on the wage determination for the applicable classification. If the Administrator determines that a different practice prevails for the applicable apprentice classification, fringes shall be paid in accordance with that determination.

In the event the Office of Apprenticeship Training, Employer and Labor Services, or a State Apprenticeship Agency recognized by the Office, withdraws approval of an apprenticeship program, the contractor will no longer be permitted to utilize apprentices at less than the applicable predetermined rate for the work performed until an acceptable program is approved.

b. Trainees (programs of the USDOL).

Except as provided in 29 CFR 5.16, trainees will not be permitted to work at less than the predetermined rate for the work performed unless they are employed pursuant to and individually registered in a program which has received prior approval, evidenced by formal certification by the U.S. Department of Labor, Employment and Training Administration.

The ratio of trainees to journeymen on the job site shall not be greater than permitted under the plan approved by the Employment and Training Administration.

Every trainee must be paid at not less than the rate specified in the approved program for the trainee's level of progress, expressed as a percentage of the journeyman hourly rate specified in the applicable wage determination. Trainees shall be paid fringe benefits in accordance with the provisions of the trainee program. If the trainee program does not mention fringe benefits, trainees shall be paid the full amount of fringe benefits listed on the wage determination unless the Administrator of the Wage and Hour Division determines that there is an apprenticeship program associated with the corresponding journeyman wage rate on the wage determination which provides for less than full fringe benefits for apprentices. Any employee listed on the payroll at a trainee rate who is not registered and participating in a training plan approved by the Employment and Training Administration shall be paid not less than the applicable wage rate on the wage determination for the classification of work actually performed. In addition, any trainee performing work on the job site in excess of the ratio permitted under the registered program shall be paid not less than the applicable wage rate on the wage determination for the work actually performed.

In the event the Employment and Training Administration withdraws approval of a training program, the contractor will no longer be permitted to utilize trainees at less than the applicable predetermined rate for the work performed until an acceptable program is approved.

c. Equal employment opportunity. The utilization of apprentices, trainees and journeymen under this part shall be in conformity with the equal employment opportunity requirements of Executive Order 11246, as amended, and 29 CFR part 30.

d. Apprentices and Trainees (programs of the U.S. DOT).

Apprentices and trainees working under apprenticeship and skill training programs which have been certified by the Secretary of Transportation as promoting EEO in connection with Federal-aid highway construction programs are not subject to the requirements of paragraph 4 of this Section IV. The straight time hourly wage rates for apprentices and trainees under such programs will be established by the particular programs. The ratio of apprentices and trainees to journeymen shall not be greater than permitted by the terms of the particular program.

**5. Compliance with Copeland Act requirements.** The contractor shall comply with the requirements of 29 CFR part 3, which are incorporated by reference in this contract.

**6. Subcontracts.** The contractor or subcontractor shall insert Form FHWA-1273 in any subcontracts and also require the subcontractors to include Form FHWA-1273 in any lower tier subcontracts. The prime contractor shall be responsible for the compliance by any subcontractor or lower tier subcontractor with all the contract clauses in 29 CFR 5.5.

**7. Contract termination: debarment.** A breach of the contract clauses in 29 CFR 5.5 may be grounds for termination of the contract, and for debarment as a contractor and a subcontractor as provided in 29 CFR 5.12.

**8. Compliance with Davis-Bacon and Related Act requirements.** All rulings and interpretations of the Davis-Bacon and Related Acts contained in 29 CFR parts 1, 3, and 5 are herein incorporated by reference in this contract.

**9. Disputes concerning labor standards.** Disputes arising out of the labor standards provisions of this contract shall not be subject to the general disputes clause of this contract. Such disputes shall be resolved in accordance with the procedures of the Department of Labor set forth in 29 CFR parts 5, 6, and 7. Disputes within the meaning of this clause include disputes between the contractor (or any of its subcontractors) and the contracting agency, the U.S. Department of Labor, or the employees or their representatives.

**10. Certification of eligibility.**

a. By entering into this contract, the contractor certifies that neither it (nor he or she) nor any person or firm who has an interest in the contractor's firm is a person or firm ineligible to be awarded Government contracts by virtue of section 3(a) of the Davis-Bacon Act or 29 CFR 5.12(a)(1).

b. No part of this contract shall be subcontracted to any person or firm ineligible for award of a Government contract by virtue of section 3(a) of the Davis-Bacon Act or 29 CFR 5.12(a)(1).

c. The penalty for making false statements is prescribed in the U.S. Criminal Code, 18 U.S.C. 1001.

**V. CONTRACT WORK HOURS AND SAFETY STANDARDS ACT**

The following clauses apply to any Federal-aid construction contract in an amount in excess of \$100,000 and subject to the overtime provisions of the Contract Work Hours and Safety Standards Act. These clauses shall be inserted in addition to the clauses required by 29 CFR 5.5(a) or 29 CFR 4.6. As used in this paragraph, the terms laborers and mechanics include watchmen and guards.

**1. Overtime requirements.** No contractor or subcontractor contracting for any part of the contract work which may require or involve the employment of laborers or mechanics shall require or permit

any such laborer or mechanic in any workweek in which he or she is employed on such work to work in excess of forty hours in such workweek unless such laborer or mechanic receives compensation at a rate not less than one and one-half times the basic rate of pay for all hours worked in excess of forty hours in such workweek.

**2. Violation; liability for unpaid wages; liquidated damages.** In the event of any violation of the clause set forth in paragraph (1.) of this section, the contractor and any subcontractor responsible therefor shall be liable for the unpaid wages. In addition, such contractor and subcontractor shall be liable to the United States (in the case of work done under contract for the District of Columbia or a territory, to such District or to such territory), for liquidated damages. Such liquidated damages shall be computed with respect to each individual laborer or mechanic, including watchmen and guards, employed in violation of the clause set forth in paragraph (1.) of this section, in the sum of \$10 for each calendar day on which such individual was required or permitted to work in excess of the standard workweek of forty hours without payment of the overtime wages required by the clause set forth in paragraph (1.) of this section.

**3. Withholding for unpaid wages and liquidated damages.** The FHWA or the contacting agency shall upon its own action or upon written request of an authorized representative of the Department of Labor withhold or cause to be withheld, from any moneys payable on account of work performed by the contractor or subcontractor under any such contract or any other Federal contract with the same prime contractor, or any other federally-assisted contract subject to the Contract Work Hours and Safety Standards Act, which is held by the same prime contractor, such sums as may be determined to be necessary to satisfy any liabilities of such contractor or subcontractor for unpaid wages and liquidated damages as provided in the clause set forth in paragraph (2.) of this section.

**4. Subcontracts.** The contractor or subcontractor shall insert in any subcontracts the clauses set forth in paragraph (1.) through (4.) of this section and also a clause requiring the subcontractors to include these clauses in any lower tier subcontracts. The prime contractor shall be responsible for compliance by any subcontractor or lower tier subcontractor with the clauses set forth in paragraphs (1.) through (4.) of this section.

## VI. SUBLETTING OR ASSIGNING THE CONTRACT

This provision is applicable to all Federal-aid construction contracts on the National Highway System.

1. The contractor shall perform with its own organization contract work amounting to not less than 30 percent (or a greater percentage if specified elsewhere in the contract) of the total original contract price, excluding any specialty items designated by the contracting agency. Specialty items may be performed by subcontract and the amount of any such specialty items performed may be deducted from the total original contract price before computing the amount of work required to be performed by the contractor's own organization (23 CFR 635.116).

a. The term “perform work with its own organization” refers to workers employed or leased by the prime contractor, and equipment owned or rented by the prime contractor, with or without operators. Such term does not include employees or equipment of a subcontractor or lower tier subcontractor, agents of the prime contractor, or any other assignees. The term may include payments for the costs of hiring leased employees from an employee leasing firm meeting all relevant Federal and State regulatory requirements. Leased employees may only be included in this term if the prime contractor meets all of the following conditions:

- (1) the prime contractor maintains control over the supervision of the day-to-day activities of the leased employees;
- (2) the prime contractor remains responsible for the quality of the work of the leased employees;
- (3) the prime contractor retains all power to accept or exclude individual employees from work on the project; and
- (4) the prime contractor remains ultimately responsible for the payment of predetermined minimum wages, the submission of payrolls, statements of compliance and all other Federal regulatory requirements.

b. "Specialty Items" shall be construed to be limited to work that requires highly specialized knowledge, abilities, or equipment not ordinarily available in the type of contracting organizations qualified and expected to bid or propose on the contract as a whole and in general are to be limited to minor components of the overall contract.

2. The contract amount upon which the requirements set forth in paragraph (1) of Section VI is computed includes the cost of material and manufactured products which are to be purchased or produced by the contractor under the contract provisions.

3. The contractor shall furnish (a) a competent superintendent or supervisor who is employed by the firm, has full authority to direct performance of the work in accordance with the contract requirements, and is in charge of all construction operations (regardless of who performs the work) and (b) such other of its own organizational resources (supervision, management, and engineering services) as the contracting officer determines is necessary to assure the performance of the contract.

4. No portion of the contract shall be sublet, assigned or otherwise disposed of except with the written consent of the contracting officer, or authorized representative, and such consent when given shall not be construed to relieve the contractor of any responsibility for the fulfillment of the contract. Written consent will be given only after the contracting agency has assured that each subcontract is evidenced in writing and that it contains all pertinent provisions and requirements of the prime contract.

5. The 30% self-performance requirement of paragraph (1) is not applicable to design-build contracts; however, contracting agencies may establish their own self-performance requirements.

## **VII. SAFETY: ACCIDENT PREVENTION**

This provision is applicable to all Federal-aid construction contracts and to all related subcontracts.

1. In the performance of this contract the contractor shall comply with all applicable Federal, State, and local laws governing safety, health, and sanitation (23 CFR 635). The contractor shall provide all safeguards, safety devices and protective equipment and take any other needed actions as it determines, or as the contracting officer may determine, to be reasonably necessary to protect the life and health of employees on the job and the safety of the public and to protect property in connection with the performance of the work covered by the contract.

2. It is a condition of this contract, and shall be made a condition of each subcontract, which the contractor enters into pursuant to this contract, that the contractor and any subcontractor shall not permit any employee, in performance of the contract, to work in surroundings or under conditions which are unsanitary, hazardous or dangerous to his/her health or safety, as determined under



construction safety and health standards (29 CFR 1926) promulgated by the Secretary of Labor, in accordance with Section 107 of the Contract Work Hours and Safety Standards Act (40 U.S.C. 3704).

3. Pursuant to 29 CFR 1926.3, it is a condition of this contract that the Secretary of Labor or authorized representative thereof, shall have right of entry to any site of contract performance to inspect or investigate the matter of compliance with the construction safety and health standards and to carry out the duties of the Secretary under Section 107 of the Contract Work Hours and Safety Standards Act (40 U.S.C.3704).

### **VIII. FALSE STATEMENTS CONCERNING HIGHWAY PROJECTS**

This provision is applicable to all Federal-aid construction contracts and to all related subcontracts.

In order to assure high quality and durable construction in conformity with approved plans and specifications and a high degree of reliability on statements and representations made by engineers, contractors, suppliers, and workers on Federal-aid highway projects, it is essential that all persons concerned with the project perform their functions as carefully, thoroughly, and honestly as possible. Willful falsification, distortion, or misrepresentation with respect to any facts related to the project is a violation of Federal law. To prevent any misunderstanding regarding the seriousness of these and similar acts, Form FHWA-1022 shall be posted on each Federal-aid highway project (23 CFR 635) in one or more places where it is readily available to all persons concerned with the project:

18 U.S.C. 1020 reads as follows:

"Whoever, being an officer, agent, or employee of the United States, or of any State or Territory, or whoever, whether a person, association, firm, or corporation, knowingly makes any false statement, false representation, or false report as to the character, quality, quantity, or cost of the material used or to be used, or the quantity or quality of the work performed or to be performed, or the cost thereof in connection with the submission of plans, maps, specifications, contracts, or costs of construction on any highway or related project submitted for approval to the Secretary of Transportation; or

Whoever knowingly makes any false statement, false representation, false report or false claim with respect to the character, quality, quantity, or cost of any work performed or to be performed, or materials furnished or to be furnished, in connection with the construction of any highway or related project approved by the Secretary of Transportation; or

Whoever knowingly makes any false statement or false representation as to material fact in any statement, certificate, or report submitted pursuant to provisions of the Federal-aid Roads Act approved July 1, 1916, (39 Stat. 355), as amended and supplemented;

Shall be fined under this title or imprisoned not more than 5 years or both."

### **IX. IMPLEMENTATION OF CLEAN AIR ACT AND FEDERAL WATER POLLUTION CONTROL ACT**

This provision is applicable to all Federal-aid construction contracts and to all related subcontracts.

By submission of this bid/proposal or the execution of this contract, or subcontract, as appropriate, the bidder, proposer, Federal-aid construction contractor, or subcontractor, as appropriate, will be deemed to have stipulated as follows:

1. That any person who is or will be utilized in the performance of this contract is not prohibited from receiving an award due to a violation of Section 508 of the Clean Water Act or Section 306 of the Clean Air Act.
2. That the contractor agrees to include or cause to be included the requirements of paragraph (1) of this Section X in every subcontract, and further agrees to take such action as the contracting agency may direct as a means of enforcing such requirements.

## **X. CERTIFICATION REGARDING DEBARMENT, SUSPENSION, INELIGIBILITY AND VOLUNTARY EXCLUSION**

This provision is applicable to all Federal-aid construction contracts, design-build contracts, subcontracts, lower-tier subcontracts, purchase orders, lease agreements, consultant contracts or any other covered transaction requiring FHWA approval or that is estimated to cost \$25,000 or more – as defined in 2 CFR Parts 180 and 1200.

### **1. Instructions for Certification – First Tier Participants:**

- a. By signing and submitting this proposal, the prospective first tier participant is providing the certification set out below.
- b. The inability of a person to provide the certification set out below will not necessarily result in denial of participation in this covered transaction. The prospective first tier participant shall submit an explanation of why it cannot provide the certification set out below. The certification or explanation will be considered in connection with the department or agency's determination whether to enter into this transaction. However, failure of the prospective first tier participant to furnish a certification or an explanation shall disqualify such a person from participation in this transaction.
- c. The certification in this clause is a material representation of fact upon which reliance was placed when the contracting agency determined to enter into this transaction. If it is later determined that the prospective participant knowingly rendered an erroneous certification, in addition to other remedies available to the Federal Government, the contracting agency may terminate this transaction for cause of default.
- d. The prospective first tier participant shall provide immediate written notice to the contracting agency to whom this proposal is submitted if any time the prospective first tier participant learns that its certification was erroneous when submitted or has become erroneous by reason of changed circumstances.
- e. The terms "covered transaction," "debarred," "suspended," "ineligible," "participant," "person," "principal," and "voluntarily excluded," as used in this clause, are defined in 2 CFR Parts 180 and 1200. "First Tier Covered Transactions" refers to any covered transaction between a grantee or subgrantee of Federal funds and a participant (such as the prime or general contract). "Lower Tier Covered Transactions" refers to any covered transaction under a First Tier Covered Transaction (such as subcontracts). "First Tier Participant" refers to the participant who has entered into a covered

transaction with a grantee or subgrantee of Federal funds (such as the prime or general contractor). “Lower Tier Participant” refers any participant who has entered into a covered transaction with a First Tier Participant or other Lower Tier Participants (such as subcontractors and suppliers).

f. The prospective first tier participant agrees by submitting this proposal that, should the proposed covered transaction be entered into, it shall not knowingly enter into any lower tier covered transaction with a person who is debarred, suspended, declared ineligible, or voluntarily excluded from participation in this covered transaction, unless authorized by the department or agency entering into this transaction.

g. The prospective first tier participant further agrees by submitting this proposal that it will include the clause titled "Certification Regarding Debarment, Suspension, Ineligibility and Voluntary Exclusion-Lower Tier Covered Transactions," provided by the department or contracting agency, entering into this covered transaction, without modification, in all lower tier covered transactions and in all solicitations for lower tier covered transactions exceeding the \$25,000 threshold.

h. A participant in a covered transaction may rely upon a certification of a prospective participant in a lower tier covered transaction that is not debarred, suspended, ineligible, or voluntarily excluded from the covered transaction, unless it knows that the certification is erroneous. A participant is responsible for ensuring that its principals are not suspended, debarred, or otherwise ineligible to participate in covered transactions. To verify the eligibility of its principals, as well as the eligibility of any lower tier prospective participants, each participant may, but is not required to, check the Excluded Parties List System website (<https://www.epls.gov/>), which is compiled by the General Services Administration.

i. Nothing contained in the foregoing shall be construed to require the establishment of a system of records in order to render in good faith the certification required by this clause. The knowledge and information of the prospective participant is not required to exceed that which is normally possessed by a prudent person in the ordinary course of business dealings.

j. Except for transactions authorized under paragraph (f) of these instructions, if a participant in a covered transaction knowingly enters into a lower tier covered transaction with a person who is suspended, debarred, ineligible, or voluntarily excluded from participation in this transaction, in addition to other remedies available to the Federal Government, the department or agency may terminate this transaction for cause or default.

\* \* \* \* \*

## 2. Certification Regarding Debarment, Suspension, Ineligibility and Voluntary Exclusion – First Tier Participants:

a. The prospective first tier participant certifies to the best of its knowledge and belief, that it and its principals:

(1) Are not presently debarred, suspended, proposed for debarment, declared ineligible, or voluntarily excluded from participating in covered transactions by any Federal department or agency;

(2) Have not within a three-year period preceding this proposal been convicted of or had a civil judgment rendered against them for commission of fraud or a criminal offense in connection with

obtaining, attempting to obtain, or performing a public (Federal, State or local) transaction or contract under a public transaction; violation of Federal or State antitrust statutes or commission of embezzlement, theft, forgery, bribery, falsification or destruction of records, making false statements, or receiving stolen property;

(3) Are not presently indicted for or otherwise criminally or civilly charged by a governmental entity (Federal, State or local) with commission of any of the offenses enumerated in paragraph (a)(2) of this certification; and

(4) Have not within a three-year period preceding this application/proposal had one or more public transactions (Federal, State or local) terminated for cause or default.

b. Where the prospective participant is unable to certify to any of the statements in this certification, such prospective participant shall attach an explanation to this proposal.

## **2. Instructions for Certification - Lower Tier Participants:**

(Applicable to all subcontracts, purchase orders and other lower tier transactions requiring prior FHWA approval or estimated to cost \$25,000 or more - 2 CFR Parts 180 and 1200)

a. By signing and submitting this proposal, the prospective lower tier is providing the certification set out below.

b. The certification in this clause is a material representation of fact upon which reliance was placed when this transaction was entered into. If it is later determined that the prospective lower tier participant knowingly rendered an erroneous certification, in addition to other remedies available to the Federal Government, the department, or agency with which this transaction originated may pursue available remedies, including suspension and/or debarment.

c. The prospective lower tier participant shall provide immediate written notice to the person to which this proposal is submitted if at any time the prospective lower tier participant learns that its certification was erroneous by reason of changed circumstances.

d. The terms "covered transaction," "debarred," "suspended," "ineligible," "participant," "person," "principal," and "voluntarily excluded," as used in this clause, are defined in 2 CFR Parts 180 and 1200. You may contact the person to which this proposal is submitted for assistance in obtaining a copy of those regulations. "First Tier Covered Transactions" refers to any covered transaction between a grantee or subgrantee of Federal funds and a participant (such as the prime or general contract). "Lower Tier Covered Transactions" refers to any covered transaction under a First Tier Covered Transaction (such as subcontracts). "First Tier Participant" refers to the participant who has entered into a covered transaction with a grantee or subgrantee of Federal funds (such as the prime or general contractor). "Lower Tier Participant" refers any participant who has entered into a covered transaction with a First Tier Participant or other Lower Tier Participants (such as subcontractors and suppliers).

e. The prospective lower tier participant agrees by submitting this proposal that, should the proposed covered transaction be entered into, it shall not knowingly enter into any lower tier covered transaction with a person who is debarred, suspended, declared ineligible, or voluntarily excluded from participation in this covered transaction, unless authorized by the department or agency with which this transaction originated.

f. The prospective lower tier participant further agrees by submitting this proposal that it will include this clause titled "Certification Regarding Debarment, Suspension, Ineligibility and Voluntary Exclusion-Lower Tier Covered Transaction," without modification, in all lower tier covered transactions and in all solicitations for lower tier covered transactions exceeding the \$25,000 threshold.

g. A participant in a covered transaction may rely upon a certification of a prospective participant in a lower tier covered transaction that is not debarred, suspended, ineligible, or voluntarily excluded from the covered transaction, unless it knows that the certification is erroneous. A participant is responsible for ensuring that its principals are not suspended, debarred, or otherwise ineligible to participate in covered transactions. To verify the eligibility of its principals, as well as the eligibility of any lower tier prospective participants, each participant may, but is not required to, check the Excluded Parties List System website (<https://www.epls.gov/>), which is compiled by the General Services Administration.

h. Nothing contained in the foregoing shall be construed to require establishment of a system of records in order to render in good faith the certification required by this clause. The knowledge and information of participant is not required to exceed that which is normally possessed by a prudent person in the ordinary course of business dealings.

i. Except for transactions authorized under paragraph e of these instructions, if a participant in a covered transaction knowingly enters into a lower tier covered transaction with a person who is suspended, debarred, ineligible, or voluntarily excluded from participation in this transaction, in addition to other remedies available to the Federal Government, the department or agency with which this transaction originated may pursue available remedies, including suspension and/or debarment.

\* \* \* \* \*

**Certification Regarding Debarment, Suspension, Ineligibility and Voluntary Exclusion--Lower Tier Participants:**

1. The prospective lower tier participant certifies, by submission of this proposal, that neither it nor its principals is presently debarred, suspended, proposed for debarment, declared ineligible, or voluntarily excluded from participating in covered transactions by any Federal department or agency.

2. Where the prospective lower tier participant is unable to certify to any of the statements in this certification, such prospective participant shall attach an explanation to this proposal.

\* \* \* \* \*

**XI. CERTIFICATION REGARDING USE OF CONTRACT FUNDS FOR LOBBYING**

This provision is applicable to all Federal-aid construction contracts and to all related subcontracts which exceed \$100,000 (49 CFR 20).

1. The prospective participant certifies, by signing and submitting this bid or proposal, to the best of his or her knowledge and belief, that:

a. No Federal appropriated funds have been paid or will be paid, by or on behalf of the undersigned, to any person for influencing or attempting to influence an officer or employee of any Federal agency,

a Member of Congress, an officer or employee of Congress, or an employee of a Member of Congress in connection with the awarding of any Federal contract, the making of any Federal grant, the making of any Federal loan, the entering into of any cooperative agreement, and the extension, continuation, renewal, amendment, or modification of any Federal contract, grant, loan, or cooperative agreement.

b. If any funds other than Federal appropriated funds have been paid or will be paid to any person for influencing or attempting to influence an officer or employee of any Federal agency, a Member of Congress, an officer or employee of Congress, or an employee of a Member of Congress in connection with this Federal contract, grant, loan, or cooperative agreement, the undersigned shall complete and submit Standard Form-LLL, "Disclosure Form to Report Lobbying," in accordance with its instructions.

2. This certification is a material representation of fact upon which reliance was placed when this transaction was made or entered into. Submission of this certification is a prerequisite for making or entering into this transaction imposed by 31 U.S.C. 1352. Any person who fails to file the required certification shall be subject to a civil penalty of not less than \$10,000 and not more than \$100,000 for each such failure.

3. The prospective participant also agrees by submitting its bid or proposal that the participant shall require that the language of this certification be included in all lower tier subcontracts, which exceed \$100,000 and that all such recipients shall certify and disclose accordingly.

**ATTACHMENT A - EMPLOYMENT AND MATERIALS PREFERENCE FOR  
APPALACHIAN DEVELOPMENT HIGHWAY SYSTEM OR APPALACHIAN LOCAL  
ACCESS ROAD CONTRACTS**

This provision is applicable to all Federal-aid projects funded under the Appalachian Regional Development Act of 1965.

1. During the performance of this contract, the contractor undertaking to do work which is, or reasonably may be, done as on-site work, shall give preference to qualified persons who regularly reside in the labor area as designated by the DOL wherein the contract work is situated, or the subregion, or the Appalachian counties of the State wherein the contract work is situated, except:

a. To the extent that qualified persons regularly residing in the area are not available.

b. For the reasonable needs of the contractor to employ supervisory or specially experienced personnel necessary to assure an efficient execution of the contract work.

c. For the obligation of the contractor to offer employment to present or former employees as the result of a lawful collective bargaining contract, provided that the number of nonresident persons employed under this subparagraph (1c) shall not exceed 20 percent of the total number of employees employed by the contractor on the contract work, except as provided in subparagraph (4) below.

2. The contractor shall place a job order with the State Employment Service indicating (a) the classifications of the laborers, mechanics and other employees required to perform the contract work, (b) the number of employees required in each classification, (c) the date on which the participant estimates such employees will be required, and (d) any other pertinent information required by the State Employment Service to complete the job order form. The job order may be placed with the State Employment Service in writing or by telephone. If during the course of the contract work, the information submitted by the contractor in the original job order is substantially modified, the participant shall promptly notify the State Employment Service.

3. The contractor shall give full consideration to all qualified job applicants referred to him by the State Employment Service. The contractor is not required to grant employment to any job applicants who, in his opinion, are not qualified to perform the classification of work required.

4. If, within one week following the placing of a job order by the contractor with the State Employment Service, the State Employment Service is unable to refer any qualified job applicants to the contractor, or less than the number requested, the State Employment Service will forward a certificate to the contractor indicating the unavailability of applicants. Such certificate shall be made a part of the contractor's permanent project records. Upon receipt of this certificate, the contractor may employ persons who do not normally reside in the labor area to fill positions covered by the certificate, notwithstanding the provisions of subparagraph (1c) above.

5. The provisions of 23 CFR 633.207(e) allow the contracting agency to provide a contractual preference for the use of mineral resource materials native to the Appalachian region.

**EXHIBIT B****TITLE VI CONTRACTOR ASSURANCES**

During the performance of this Contract, the contractor, for itself, its assignees and successors in interest (hereinafter referred to as the "Contractor") agrees as follows:

1. **Compliance with Regulations:** The Contractor shall comply with the regulations relative to nondiscrimination in federally assisted programs of the United States Department of Transportation (hereinafter, "USDOT"), Title 49, Code of Federal Regulations, Part 21, as they may be amended from time to time (hereinafter referred to as the "Regulations"), which are herein incorporated by reference and made a part of this contract.

2. **Nondiscrimination:** The Contractor, with regard to the work performed by it during the Contract, shall not discriminate on the grounds of race, color, national origin, sex, age, or disability in the selection and retention of subcontractors, including procurements of materials and leases of equipment. The Contractor shall not participate either directly or indirectly in the discrimination prohibited by Subsection 5 of the Regulations, including employment practices when the Contract covers a program set forth in Appendix B of the Regulations.

3. **Solicitations for Subcontracts, Including Procurements of Materials and Equipment:**

In all solicitations either by competitive bidding or negotiation made by the Contractor for work to be performed under a subcontract, including procurements of materials or leases of equipment, each potential subcontractor or supplier shall be notified by the Contractor of the Contractor's obligations under this contract and the Regulations relative to nondiscrimination on the grounds of race, color, national origin, sex, age, or disability.

4. **Information and Reports:** The Contractor shall provide all information and reports required by the Regulations or directives issued pursuant thereto and shall permit access to its books, records, accounts, other sources of information, and its facilities as may be determined by the Connecticut Department of Transportation (ConnDOT) or the Funding Agency (FHWA, FTA and FAA) to be pertinent to ascertain compliance with such Regulations, orders, and instructions. Where any information required of a Contractor is in the exclusive possession of another who fails or refuses to furnish this information, the Contractor shall so certify to ConnDOT or the Funding Agency, as appropriate, and shall set forth what efforts it has made to obtain the information.

5. **Sanctions for Noncompliance:** In the event of the Contractor's noncompliance with the nondiscrimination provisions of this Contract, the ConnDOT shall impose such sanctions as it or the Funding Agency may determine to be appropriate, including, but not limited to:

- A. Withholding contract payments until the Contractor is in-compliance; and/or
- B. Cancellation, termination, or suspension of the Contract, in whole or in part.

6. **Incorporation of Provisions:** The Contractor shall include the provisions of paragraphs 1 through 5 in every subcontract, including procurements of materials and leases of equipment, unless exempt by the Regulations or directives issued pursuant thereto. The Contractor shall take such action with respect to any subcontract or procurement as the ConnDOT or the Funding Agency may -direct as a means of enforcing such provisions including sanctions for noncompliance. Provided, however, that in the event a Contractor becomes involved in, or is threatened with, litigation with a subcontractor or supplier as a result of such direction, the Contractor may request the ConnDOT to enter into such litigation to protect the interests of the Funding Agency, and, in addition, the Contractor may request the United States to enter into such litigation to protect the interests of the United States



**EXHIBIT C****CONTRACTOR WORKFORCE UTILIZATION (FEDERAL EXECUTIVE ORDER 11246) /  
EQUAL EMPLOYMENT OPPORTUNITY  
(Federal - FHWA)****1. Project Workforce Utilization Goals:**

These goals are applicable to all the Contractor's construction work (whether or not it is Federal or Federally assisted or funded) performed in the covered area. If the contractor performs construction work in a geographical area located outside of the covered area, it shall apply the goals established for the geographical area where the work is actually performed.

Whenever the Contractor, or any Subcontractor at any tier, subcontracts a portion of the work involving any construction trade, it shall physically include in each subcontract in excess of \$10,000 the provisions of these specifications which contain the applicable goals for minority and female participation.

The goals for minority and female utilization are expressed in percentage terms for the contractor's aggregate work-force in each trade on all construction work in the covered area, are referenced in the attached Appendix A.

**2. Executive Order 11246**

The Contractor's compliance with Executive Order 11246 and 41-CFR Part 60-4 shall be based on its implementation of the specific affirmative action obligations required by the specifications set forth in 41 CFR 60-4.3(A) and its efforts to meet the goals established for the geographical area where the contract is to be performed. The hours of minority and female employment and training must be substantially uniform throughout the length of the contract, and in each trade, and the contractor shall make a good faith effort to employ minorities and women evenly on each of its projects. The transfer of minority or female employees or trainees from contractor to contractor or from project to project for the sole purpose of meeting the contractor's goals shall be a violation of the contract, the Executive Order and the regulations in 41 CFR Part 60-4. Compliance with the goals will be measured against the total work hour performed.

If the Contractor is participating (pursuant to 41 CFR 60-4.5) in a Hometown Plan approved by the U.S. Department of Labor in the covered area either individually or through an association, its affirmative action obligations on all work in the Plan area (including goals and timetables) shall be in accordance with that Plan for those trades which have unions participating in the Plan. Contractors must be able to demonstrate their participation in and compliance with the provisions of any such Hometown Plan. Each Contractor or Subcontractor participating in an approved Plan is individually required to comply with its obligations under the EEO clause, and to make a good faith effort to achieve each goal under the Plan in each trade in which it has employees. The overall good faith performance by other Contractors or subcontractors toward a goal in an approved Pan does not excuse any covered Contractor's of subcontractor's failure to take good faith efforts to achieve the plan goals and timetables.

The Contractor shall implement the specific affirmative action standards provided in a through p of these specifications. The goals set forth in the solicitation from which this contract resulted are expressed as percentages of the total hours of employment and training of minority and female utilization the Contractor should reasonably be able to achieve in each construction trade in

which it has employees in the covered area. Covered Construction contractors performing construction work in geographical areas where they do not have a federal or federally assisted construction contract shall apply the minority and female goals established for the geographical area where the work is being performed. Goals are published periodically in the Federal Register in notice form and such notices may be obtained from any Office of Federal Contract Compliance Programs (OFCCP) Office or from Federal procurement contracting officers. The Contractor is expected to make substantially uniform progress in meeting its goals in each craft during the period specified.

Neither the provisions of any collective bargaining agreement, nor the failure by a union with whom the Contractor has a collective bargaining agreement, to refer either minorities or women shall excuse the Contractor's obligations under these specifications, Executive Order 11246, or the regulations promulgated pursuant hereto.

In order for the nonworking training hours of apprentices and trainees to be counted in meeting the goals, such apprentices and trainees must be employed by the Contractor during the training period, and the Contractor must have made a commitment to employ the apprentices and trainees at the completion of their training, subject to the availability of employment opportunities. Trainees must be trained pursuant to training programs approved by the U.S. Department of Labor.

The Contractor shall take specific affirmative actions to ensure equal employment opportunity. The evaluation of the Contractor's compliance with these specifications shall be based upon its effort to achieve maximum results from its actions. The Contractor shall document these efforts fully, and shall implement affirmative action steps at least as extensive as the following:

- a. Ensure and maintain a working environment free of harassment, intimidation, and coercion at all sites; and in all facilities at which the Contractor's employees are assigned to work. The Contractor, where possible, will assign two or more women to each construction project. The Contractor shall specifically ensure that all foremen, superintendents, and other on-site supervisory personnel are aware of and carry out the Contractor's obligation to maintain such a working environment, with specific attention to minority or female individuals working at such sites or in such facilities.
- b. Establish and maintain a current list of minority and female recruitment sources, provide written notification to minority and female recruitment sources and to community organizations when the Contractor or its unions have employment opportunities available, and maintain a record of the organizations' responses.
- c. Maintain a current file of the names, addresses and telephone numbers of each minority and female off the street applicant and minority or female referral from a union, a recruitment source or community organization and of what action was taken with respect to each such individual. If such individual was sent to the union hiring hall for referral and was not referred back to the Contractor by the union or, if referred, not employed by the Contractor, this shall be documented in the file with the reason thereafter; along with whatever additional actions the Contractor may have taken.
- d. Provide immediate written notification to the Director when the Union or Unions with which the Contractor has a collective bargaining agreement has not referred to the Contractor a minority person or women sent by the Contractor, or when the Contractor has other

information that the Union referral process has impeded the Contractor's efforts to meet its obligations.

- e. Develop on-the-job training opportunities and/or participate in training programs for the area which expressly include minorities and women, including upgrading programs and apprenticeship and trainee programs relevant to the Contractor's employment needs, especially those programs funded or approved by the Department of Labor. The Contractor shall provide notice of these programs to the sources compiled under b above.
- f. Disseminate the Contractor's EEO policy by providing notice of the policy to unions and training programs and requesting their cooperation in assisting the Contractor in meeting its EEO obligations; by including it in any policy manual and collective bargaining agreement; by publicizing it in the company newspaper, annual report, etc.; by specific review of the policy with all management personnel and with all minority and female employees at least once a year; and by posting the company EEO Policy on bulletin boards accessible to all employees at each location where construction work is performed.
- g. Review, at least annually, the company EEO Policy and affirmative action obligations under these specifications with all employees having any responsibility for hiring, assignment, layoff, termination or other employment, decisions including specific Foreman, etc. prior to the initiation of construction work at any job site. A written record shall be made and maintained identifying the time and place of these meetings, persons attending, subject matter discussed, and disposition of the subject matter.
- h. Disseminate the Contractor's EEO Policy externally by including it in any advertising in the news media, specifically including minority and female news media, and providing written notification to and discussing the Contractor's EEO policy with other Contractors and subcontractors with whom the Contractor does or anticipates doing business.
- i. Direct its recruitment efforts, both oral and written, to minority female and community organizations, to schools with minority and female students and to minority and female recruitment and training organizations serving the Contractor's recruitment area and employment needs. Not later than one month prior to the date for the acceptance of applications for apprenticeship or other training by any recruitment source, the contractor shall send written notification to organizations such as the above, describing the openings, screening procedures and tests to be used in the selection process.
- j. Encourage present minority and female employees to recruit other minority persons and women and, where reasonable, provide after school, summer and vacation employment to minority and female youth both on the site and in other areas of a Contractor's work-force.
- k. Validate all tests and other selection requirements where there is an obligation to do so under 41 CFR Part 60-3.
- l. Conduct, at least annually, an inventory and evaluation at least of all minority and female personnel for promotional opportunities and encourage these employees to seek or to prepare for, through appropriate training, etc., such opportunities.
- m. Ensure that seniority practices, job classifications, work assignments and other personnel practices, do not have a discriminatory effect by continually monitoring all personnel and

employment related activities to ensure that the EEO policy and the Contractor's obligations under these specifications are being carried out.

- n. Ensure that all facilities and company activities are non-segregated except that separate or single user toilet and necessary changing facilities shall be provided to assure privacy between the sexes.
- o. Document and maintain a record of all solicitations of offers for subcontracts from minority and female construction contractors and suppliers, including circulation of solicitations to minority and female contractor associations and other business associations.
- p. Conduct a review at least annually of all supervisors' adherence to and performance under the Contractor's EEO policies and affirmative action obligations.

Contractors are encouraged to participate in voluntary associations which assist in fulfilling one or more of their affirmative action obligations (a through p). The efforts of a contractor association, joint contractor union, contractor community, or other similar group of which the contractor is a member and participant, may be asserted as fulfilling any one or more of its obligations under a through p of these specifications provided that the contractor actively participates in the group, makes every effort to assure that the group has a positive impact on the employment of minorities and women in the industry, ensures that the concrete benefits of the program are reflected in the Contractor's minority and female work-force participation, makes a good faith effort to meet with individual goals and timetables, and can provide access to documentation which demonstrates the effectiveness of actions taken on behalf of the Contractor. The obligation to comply, however, is the Contractor's and failure of such a group to fulfill an obligation shall not be a defense for the Contractor's noncompliance.

A single goal for minorities and a separate single goal for women have been established. The Contractor, however, is required to provide equal employment opportunity and to take affirmative action for all minority groups, both male and female, and all women, both minority and non-minority. Consequently, the Contractor may be in violation of Executive Order 11246 if a particular group is employed in a substantially disparate manner, (for example, even though the Contractor has achieved its goals for women generally, the Contractor may be in violation of the Executive Order if a specific minority group of women is under utilized).

The Contractor shall not use the goals and timetables or affirmative action standards to discriminate against any person because of race, color, religion, sex, or national origin.

The Contractor shall not enter into any Subcontract with any person or firm debarred from Government contracts pursuant to Executive Order 11246.

The Contractor shall carry out such sanctions and penalties for violation of these specifications and of the Equal Opportunity Clause, including suspension, termination and cancellation of existing subcontracts as may be imposed or ordered pursuant to Executive Order 11246, as amended, and its implementing regulations by the Office of Federal Contract Compliance Programs. Any Contractor who fails to carry out such sanctions and penalties shall be in violation of these specifications and Executive Order 11246, as amended.

The Contractor, in fulfilling its obligations under these specifications, shall implement specific affirmative action steps, at least as extensive as those standards prescribed in these

specifications, so as to achieve maximum results from its efforts to ensure equal employment opportunity. If the Contractor fails to comply with the requirements of the Executive Order, the implementing regulations, or these specifications, the Director shall proceed in accordance with 41 CFR 60-4.8.

The Contractor shall designate a responsible official to monitor all employment related activity to ensure that the company EEO policy is being carried out, to submit reports relating to the provisions hereof as may be required by the Government and to keep records. Records shall at least include for each employee the name, address, telephone numbers, construction trade, union affiliation if any, employee identification number when assigned, social security number, race, sex, status, (e.g. mechanic, apprentice, trainee, helper, or laborer) dates of changes in status, hours worked per week in the indicated trade, rate of pay, and locations at which the work was performed. Records shall be maintained in an easily understandable and retrievable form; however, to the degree that existing records satisfy this requirement, contractors shall not be required to maintain separate records.

Nothing herein provided shall be construed as a limitation upon the application of their laws which establish different standards of compliance or upon the application of requirements for the hiring of local or other area residents (e.g. those under the Public Works Employment Act of 1977 and the Community Development Block Grant Program).

The Director of the Office of Federal Contract Compliance Programs, from time to time, shall issue goals and timetables for minority and female utilization which shall be based on appropriate workforce, demographic or other relevant data and which shall cover construction projects or construction contracts performed in specific geographical areas. The goals, which shall be applicable to each construction trade in a covered contractor's or timetables, shall be published as notices in the Federal Register, and shall be inserted by the Contracting officers and applicants, as applicable, in the Notice required by 41 CFR 60-4.2.

**FEDERALLY FUNDED OR ASSISTED PROJECTS**  
**APPENDIX A**  
**(Labor Market Goals)**

**Standard Metropolitan Statistical Area (SMSA)**

**Female**

**Minority**

<b>Bridgeport – Stamford – Norwalk – Danbury</b>	<b>10.2%</b>
<b>6.9%</b>	

Bethel	Bridgeport	Brookfield	Danbury
Darien	Derby	Easton	Fairfield
Greenwich	Milford	Monroe	New Canaan
New Fairfield	Newton	Norwalk	Redding
Shelton	Stamford	Stratford	Trumbull
Weston	Westport	Wilton	

<b>Hartford – Bristol – New Britain</b>	<b>6.9%</b>
<b>6.9%</b>	

Andover	Avon	Berlin	Bloomfield
Bolton	Bristol	Burlington	Canton
Colchester	Columbia	Coventry	Cromwell
East Granby	East Hampton	East Hartford	East Windsor
Ellington	Enfield	Farmington	Glastonbury
Granby	Hartford	Hebron	Manchester
Marlborough	New Britain	New Hartford	Newington
Plainville	Plymouth	Portland	Rocky Hill
Simsbury	South Windsor	Southington	Stafford
Suffield	Tolland	Vernon	West Hartford
Wethersfield	Willington	Windsor	Windsor Locks

<b>New Haven – Waterbury – Meriden</b>	<b>9.0%</b>
<b>6.9%</b>	

Beacon Falls	Bethany	Branford	Cheshire
Clinton	East Haven	Guilford	Hamden
Madison	Meriden	Middlebury	Naugatuck
New Haven	North Branford	North Haven	Orange
Prospect	Southbury	Thomaston	Wallingford
Waterbury	Watertown	West Haven	Wolcott
Woodbridge	Woodbury		

<b>New London – Norwich</b>	<b>4.5%</b>
<b>6.9%</b>	

Bozrah	East Lyme	Griswold	Groton
Ledyard	Lisbon	Montville	New London
Norwich	Old Lyme	Old Saybrook	Preston
Sprague	Stonington	Waterford	

**Non SMSA****Female****Minority**

<b>Litchfield – Windham</b>			<b>5.9%</b>
<b>6.9%</b>			
Abington	Ashford	Ballouville	Bantam
Barkhamsted	Bethlehem	Bridgewater	Brooklyn
Canaan	Canterbury	Central Village	Cahplin
Colebrook	Cornwall	Cornwall Bridge	Danielson
Dayville	East Canaan	East Killingly	East Woodstock
Eastford	Falls Village	Gaylordsville	Goshen
Grosvenor Dale	Hampton	Harwinton	Kent
Killigly	Lakeside	Litchfield	Moosup
Morris	New Milford	New Preston	New Preston Marble Dale
Norfolk	North Canaan	No. Grosvenordale	North Windham
Oneco	Pequabuck	Pine Meadow	Plainfield
Pleasant Valley	Pomfret	Pomfret Center	Putnam
Quinebaug	Riverton	Rogers	Roxbury
Salisbury	Scotland	Sharon	South Kent
South Woodstock	Sterling	Taconic	Terryville
Thompson	Torrington	Warren	Warrenville
Washington	Washington Depot	Wauregan	West Cornwall
Willimantic	Winchester	Winchester Center	Windham
Winsted	Woodstock	Woodstock Valley	

**EXHIBIT D****Health Insurance Portability and Accountability Act of 1996 (“HIPAA”).**

- (a) If the Contactor is a Business Associate under the requirements of the Health Insurance Portability and Accountability Act of 1996 (“HIPAA”), the Contractor must comply with all terms and conditions of this Section of the Contract. If the Contractor is not a Business Associate under HIPAA, this Section of the Contract does not apply to the Contractor for this Contract.
- (b) The Contractor is required to safeguard the use, publication and disclosure of information on all applicants for, and all clients who receive, services under the Contract in accordance with all applicable federal and state law regarding confidentiality, which includes but is not limited to HIPAA, more specifically with the Privacy and Security Rules at 45 C.F.R. Part 160 and Part 164, subparts A, C, and E; and
- (c) The State of Connecticut Agency named on page 1 of this Contract (hereinafter the “Department”) is a “covered entity” as that term is defined in 45 C.F.R. § 160.103; and
- (d) The Contractor, on behalf of the Department, performs functions that involve the use or disclosure of “individually identifiable health information,” as that term is defined in 45 C.F.R. § 160.103; and
- (e) The Contractor is a “business associate” of the Department, as that term is defined in 45 C.F.R. § 160.103; and
- (f) The Contractor and the Department agree to the following in order to secure compliance with the HIPAA, the requirements of Subtitle D of the Health Information Technology for Economic and Clinical Health Act (hereinafter the HITECH Act), (Pub. L. 111-5, sections 13400 to 13423), and more specifically with the Privacy and Security Rules at 45 C.F.R. Part 160 and Part 164, subparts A, C, and E.
- (g) Definitions
  - (1) “Breach shall have the same meaning as the term is defined in section 13400 of the HITECH Act (42 U.S.C. §17921(1))
  - (2) “Business Associate” shall mean the Contractor.
  - (3) “Covered Entity” shall mean the Department of the State of Connecticut named on page 1 of this Contract.
  - (4) “Designated Record Set” shall have the same meaning as the term “designated record set” in 45 C.F.R. § 164.501.
  - (5) “Electronic Health Record” shall have the same meaning as the term is defined in section 13400 of the HITECH Act (42 U.S.C. §17921(5))



- (6) "Individual" shall have the same meaning as the term "individual" in 45 C.F.R. § 160.103 and shall include a person who qualifies as a personal representative as defined in 45 C.F.R. § 164.502(g).
  - (7) "Privacy Rule" shall mean the Standards for Privacy of Individually Identifiable Health Information at 45 C.F.R. part 160 and parts 164, subparts A and E.
  - (8) "Protected Health Information" or "PHI" shall have the same meaning as the term "protected health information" in 45 C.F.R. § 160.103, limited to information created or received by the Business Associate from or on behalf of the Covered Entity.
  - (9) "Required by Law" shall have the same meaning as the term "required by law" in 45 C.F.R. § 164.103.
  - (10) "Secretary" shall mean the Secretary of the Department of Health and Human Services or his designee.
  - (11) "More stringent" shall have the same meaning as the term "more stringent" in 45 C.F.R. § 160.202.
  - (12) "This Section of the Contract" refers to the HIPAA Provisions stated herein, in their entirety.
  - (13) "Security Incident" shall have the same meaning as the term "security incident" in 45 C.F.R. § 164.304.
  - (14) "Security Rule" shall mean the Security Standards for the Protection of Electronic Protected Health Information at 45 C.F.R. part 160 and parts 164, subpart A and C.
  - (15) "Unsecured protected health information" shall have the same meaning as the term as defined in section 13402(h)(1)(A) of HITECH. Act. (42 U.S.C. §17932(h)(1)(A)).
- (h) Obligations and Activities of Business Associates.
- (1) Business Associate agrees not to use or disclose PHI other than as permitted or required by this Section of the Contract or as Required by Law.
  - (2) Business Associate agrees to use appropriate safeguards to prevent use or disclosure of PHI other than as provided for in this Section of the Contract.
  - (3) Business Associate agrees to use administrative, physical and technical safeguards that reasonably and appropriately protect the confidentiality, integrity, and availability of electronic protected health information that it creates, receives, maintains, or transmits on behalf of the Covered Entity.
  - (4) Business Associate agrees to mitigate, to the extent practicable, any harmful effect that is known to the Business Associate of a use or disclosure of PHI by Business Associate in violation of this Section of the Contract.

- (5) Business Associate agrees to report to Covered Entity any use or disclosure of PHI not provided for by this Section of the Contract or any security incident of which it becomes aware.
- (6) Business Associate agrees to insure that any agent, including a subcontractor, to whom it provides PHI received from, or created or received by Business Associate, on behalf of the Covered Entity, agrees to the same restrictions and conditions that apply through this Section of the Contract to Business Associate with respect to such information.
- (7) Business Associate agrees to provide access, at the request of the Covered Entity, and in the time and manner agreed to by the parties, to PHI in a Designated Record Set, to Covered Entity or, as directed by Covered Entity, to an Individual in order to meet the requirements under 45 C.F.R. § 164.524.
- (8) Business Associate agrees to make any amendments to PHI in a Designated Record Set that the Covered Entity directs or agrees to pursuant to 45 C.F.R. § 164.526 at the request of the Covered Entity, and in the time and manner agreed to by the parties.
- (9) Business Associate agrees to make internal practices, books, and records, including policies and procedures and PHI, relating to the use and disclosure of PHI received from, or created or received by, Business Associate on behalf of Covered Entity, available to Covered Entity or to the Secretary in a time and manner agreed to by the parties or designated by the Secretary, for purposes of the Secretary determining Covered Entity's compliance with the Privacy Rule.
- (10) Business Associate agrees to document such disclosures of PHI and information related to such disclosures as would be required for Covered Entity to respond to a request by an Individual for an accounting of disclosures of PHI in accordance with 45 C.F.R. § 164.528 and section 13405 of the HITECH Act (42 U.S.C. § 17935) and any regulations promulgated thereunder.
- (11) Business Associate agrees to provide to Covered Entity, in a time and manner agreed to by the parties, information collected in accordance with clause h. (10) of this Section of the Contract, to permit Covered Entity to respond to a request by an Individual for an accounting of disclosures of PHI in accordance with 45 C.F.R. § 164.528 and section 13405 of the HITECH Act (42 U.S.C. § 17935) and any regulations promulgated thereunder. Business Associate agrees at the Covered Entity's direction to provide an accounting of disclosures of PHI directly to an individual in accordance with 45 C.F.R. § 164.528 and section 13405 of the HITECH Act (42 U.S.C. § 17935) and any regulations promulgated thereunder.
- (12) Business Associate agrees to comply with any state or federal law that is more stringent than the Privacy Rule.
- (13) Business Associate agrees to comply with the requirements of the HITECH Act relating to privacy and security that are applicable to the Covered Entity and with the requirements of 45 C.F.R. sections 164.504(e), 164.308, 164.310, 164.312, and 164.316.

- (14) In the event that an individual requests that the Business Associate (a) restrict disclosures of PHI; (b) provide an accounting of disclosures of the individual's PHI; or (c) provide a copy of the individual's PHI in an electronic health record, the Business Associate agrees to notify the covered entity, in writing, within two business days of the request.
- (15) Business Associate agrees that it shall not, directly or indirectly, receive any remuneration in exchange for PHI of an individual without (1) the written approval of the covered entity, unless receipt of remuneration in exchange for PHI is expressly authorized by this Contract and (2) the valid authorization of the individual, except for the purposes provided under section 13405(d)(2) of the HITECH Act,(42 U.S.C. § 17935(d)(2)) and in any accompanying regulations
- (16) Obligations in the Event of a Breach
- A. The Business Associate agrees that, following the discovery of a breach of unsecured protected health information, it shall notify the Covered Entity of such breach in accordance with the requirements of section 13402 of HITECH (42 U.S.C. 17932(b) and the provisions of this Section of the Contract.
- B. Such notification shall be provided by the Business Associate to the Covered Entity without unreasonable delay, and in no case later than 30 days after the breach is discovered by the Business Associate, except as otherwise instructed in writing by a law enforcement official pursuant to section 13402 (g) of HITECH (42 U.S.C. 17932(g)) . A breach is considered discovered as of the first day on which it is, or reasonably should have been, known to the Business Associate. The notification shall include the identification and last known address, phone number and email address of each individual (or the next of kin of the individual if the individual is deceased) whose unsecured protected health information has been, or is reasonably believed by the Business Associate to have been, accessed, acquired, or disclosed during such breach.
- C. The Business Associate agrees to include in the notification to the Covered Entity at least the following information:
1. A brief description of what happened, including the date of the breach and the date of the discovery of the breach, if known.
  2. A description of the types of unsecured protected health information that were involved in the breach (such as full name, Social Security number, date of birth, home address, account number, or disability code).
  3. The steps the Business Associate recommends that individuals take to protect themselves from potential harm resulting from the breach.
  4. A detailed description of what the Business Associate is doing to investigate the breach, to mitigate losses, and to protect against any further breaches.
  5. Whether a law enforcement official has advised either verbally or in writing the Business Associate that he or she has determined that notification or notice to

individuals or the posting required under section 13402 of the HITECH Act would impede a criminal investigation or cause damage to national security and; if so, include contact information for said official.

- D. Business Associate agrees to provide appropriate staffing and have established procedures to ensure that individuals informed by the Covered Entity of a breach by the Business Associate have the opportunity to ask questions and contact the Business Associate for additional information regarding the breach. Such procedures shall include a toll-free telephone number, an e-mail address, a posting on its Web site and a postal address. Business Associate agrees to include in the notification of a breach by the Business Associate to the Covered Entity, a written description of the procedures that have been established to meet these requirements. Costs of such contact procedures will be borne by the Contractor.
  - E. Business Associate agrees that, in the event of a breach, it has the burden to demonstrate that it has complied with all notifications requirements set forth above, including evidence demonstrating the necessity of a delay in notification to the Covered Entity.
- (i) Permitted Uses and Disclosure by Business Associate.
- (1) General Use and Disclosure Provisions Except as otherwise limited in this Section of the Contract, Business Associate may use or disclose PHI to perform functions, activities, or services for, or on behalf of, Covered Entity as specified in this Contract, provided that such use or disclosure would not violate the Privacy Rule if done by Covered Entity or the minimum necessary policies and procedures of the Covered Entity.
  - (2) Specific Use and Disclosure Provisions
    - (A) Except as otherwise limited in this Section of the Contract, Business Associate may use PHI for the proper management and administration of Business Associate or to carry out the legal responsibilities of Business Associate.
    - (B) Except as otherwise limited in this Section of the Contract, Business Associate may disclose PHI for the proper management and administration of Business Associate, provided that disclosures are Required by Law, or Business Associate obtains reasonable assurances from the person to whom the information is disclosed that it will remain confidential and used or further disclosed only as Required by Law or for the purpose for which it was disclosed to the person, and the person notifies Business Associate of any instances of which it is aware in which the confidentiality of the information has been breached.
    - (C) Except as otherwise limited in this Section of the Contract, Business Associate may use PHI to provide Data Aggregation services to Covered Entity as permitted by 45 C.F.R. § 164.504(e)(2)(i)(B).
- (j) Obligations of Covered Entity.

- (1) Covered Entity shall notify Business Associate of any limitations in its notice of privacy practices of Covered Entity, in accordance with 45 C.F.R. § 164.520, or to the extent that such limitation may affect Business Associate's use or disclosure of PHI.
  - (2) Covered Entity shall notify Business Associate of any changes in, or revocation of, permission by Individual to use or disclose PHI, to the extent that such changes may affect Business Associate's use or disclosure of PHI.
  - (3) Covered Entity shall notify Business Associate of any restriction to the use or disclosure of PHI that Covered Entity has agreed to in accordance with 45 C.F.R. § 164.522, to the extent that such restriction may affect Business Associate's use or disclosure of PHI.
- (k) Permissible Requests by Covered Entity. Covered Entity shall not request Business Associate to use or disclose PHI in any manner that would not be permissible under the Privacy Rule if done by the Covered Entity, except that Business Associate may use and disclose PHI for data aggregation, and management and administrative activities of Business Associate, as permitted under this Section of the Contract.
- (l) Term and Termination.
- (1) Term. The Term of this Section of the Contract shall be effective as of the date the Contract is effective and shall terminate when the information collected in accordance with clause h. (10) of this Section of the Contract is provided to the Covered Entity and all of the PHI provided by Covered Entity to Business Associate, or created or received by Business Associate on behalf of Covered Entity, is destroyed or returned to Covered Entity, or, if it is infeasible to return or destroy PHI, protections are extended to such information, in accordance with the termination provisions in this Section.
  - (2) Termination for Cause Upon Covered Entity's knowledge of a material breach by Business Associate, Covered Entity shall either:
    - (A) Provide an opportunity for Business Associate to cure the breach or end the violation and terminate the Contract if Business Associate does not cure the breach or end the violation within the time specified by the Covered Entity; or
    - (B) Immediately terminate the Contract if Business Associate has breached a material term of this Section of the Contract and cure is not possible; or
    - (C) If neither termination nor cure is feasible, Covered Entity shall report the violation to the Secretary.
  - (3) Effect of Termination
    - (A) Except as provided in (l)(2) of this Section of the Contract, upon termination of this Contract, for any reason, Business Associate shall return or destroy all PHI received from Covered Entity, or created or received by Business Associate on behalf of Covered Entity. Business Associate shall also provide the information collected in accordance with clause h. (10) of this Section of the Contract to the Covered Entity

within ten business days of the notice of termination. This provision shall apply to PHI that is in the possession of subcontractors or agents of Business Associate. Business Associate shall retain no copies of the PHI.

(B) In the event that Business Associate determines that returning or destroying the PHI is infeasible, Business Associate shall provide to Covered Entity notification of the conditions that make return or destruction infeasible. Upon documentation by Business Associate that return or destruction of PHI is infeasible, Business Associate shall extend the protections of this Section of the Contract to such PHI and limit further uses and disclosures of PHI to those purposes that make return or destruction infeasible, for as long as Business Associate maintains such PHI. Infeasibility of the return or destruction of PHI includes, but is not limited to, requirements under state or federal law that the Business Associate maintains or preserves the PHI or copies thereof.

(m) Miscellaneous Provisions.

(1) Regulatory References. A reference in this Section of the Contract to a section in the Privacy Rule means the section as in effect or as amended.

(2) Amendment. The Parties agree to take such action as is necessary to amend this Section of the Contract from time to time as is necessary for Covered Entity to comply with requirements of the Privacy Rule and the Health Insurance Portability and Accountability Act of 1996, Pub. L. No. 104-191.

(3) Survival. The respective rights and obligations of Business Associate shall survive the termination of this Contract.

(4) Effect on Contract. Except as specifically required to implement the purposes of this Section of the Contract, all other terms of the Contract shall remain in force and effect.

(5) Construction. This Section of the Contract shall be construed as broadly as necessary to implement and comply with the Privacy Standard. Any ambiguity in this Section of the Contract shall be resolved in favor of a meaning that complies, and is consistent with, the Privacy Standard.

(6) Disclaimer. Covered Entity makes no warranty or representation that compliance with this Section of the Contract will be adequate or satisfactory for Business Associate's own purposes. Covered Entity shall not be liable to Business Associate for any claim, civil or criminal penalty, loss or damage related to or arising from the unauthorized use or disclosure of PHI by Business Associate or any of its officers, directors, employees, contractors or agents, or any third party to whom Business Associate has disclosed PHI contrary to the provisions of this Contract or applicable law. Business Associate is solely responsible for all decisions made, and actions taken, by Business Associate regarding the safeguarding, use and disclosure of PHI within its possession, custody or control.

(7) Indemnification. The Business Associate shall indemnify and hold the Covered Entity harmless from and against any and all claims, liabilities, judgments, fines, assessments, penalties, awards and any statutory damages that may be imposed or assessed pursuant to HIPAA, as amended or the

HITECH Act, including, without limitation, attorney's fees, expert witness fees, costs of investigation, litigation or dispute resolution, and costs awarded thereunder, relating to or arising out of any violation by the Business Associate and its agents, including subcontractors, of any obligation of Business Associate and its agents, including subcontractors, under this section of the contract, under HIPAA, the HITECH Act, the Privacy Rule and the Security Rule.

## Notice to Executive Branch State Contractors and Prospective State Contractors of Campaign Contribution and Solicitation Limitations

This notice is provided under the authority of Connecticut General Statutes §9-612(g)(2), as amended by P.A. 10-1, and is for the purpose of informing state contractors and prospective state contractors of the following law (*italicized words are defined on the reverse side of this page*).

### CAMPAIGN CONTRIBUTION AND SOLICITATION LIMITATIONS

No *state contractor, prospective state contractor, principal of a state contractor or principal of a prospective state contractor*, with regard to a *state contract or state contract solicitation* with or from a state agency in the executive branch or a quasi-public agency or a holder, or principal of a holder of a valid prequalification certificate, shall make a contribution to (i) an exploratory committee or candidate committee established by a candidate for nomination or election to the office of Governor, Lieutenant Governor, Attorney General, State Comptroller, Secretary of the State or State Treasurer, (ii) a political committee authorized to make contributions or expenditures to or for the benefit of such candidates, or (iii) a party committee (which includes town committees).

In addition, no holder or principal of a holder of a valid prequalification certificate, shall make a contribution to (i) an exploratory committee or candidate committee established by a candidate for nomination or election to the office of State senator or State representative, (ii) a political committee authorized to make contributions or expenditures to or for the benefit of such candidates, or (iii) a party committee.

On and after January 1, 2011, no state contractor, prospective state contractor, principal of a state contractor or principal of a prospective state contractor, with regard to a state contract or state contract solicitation with or from a state agency in the executive branch or a quasi-public agency or a holder, or principal of a holder of a valid prequalification certificate, shall **knowingly solicit** contributions from the state contractor's or prospective state contractor's employees or from a *subcontractor or principals of the subcontractor* on behalf of (i) an exploratory committee or candidate committee established by a candidate for nomination or election to the office of Governor, Lieutenant Governor, Attorney General, State Comptroller, Secretary of the State or State Treasurer, (ii) a political committee authorized to make contributions or expenditures to or for the benefit of such candidates, or (iii) a party committee.

### DUTY TO INFORM

State contractors and prospective state contractors are required to inform their principals of the above prohibitions, as applicable, and the possible penalties and other consequences of any violation thereof.

### PENALTIES FOR VIOLATIONS

Contributions or solicitations of contributions made in violation of the above prohibitions may result in the following civil and criminal penalties:

**Civil penalties**—Up to \$2,000 or twice the amount of the prohibited contribution, whichever is greater, against a principal or a contractor. Any state contractor or prospective state contractor which fails to make reasonable efforts to comply with the provisions requiring notice to its principals of these prohibitions and the possible consequences of their violations may also be subject to civil penalties of up to \$2,000 or twice the amount of the prohibited contributions made by their principals.

**Criminal penalties**—Any knowing and willful violation of the prohibition is a Class D felony, which may subject the violator to imprisonment of not more than 5 years, or not more than \$5,000 in fines, or both.

### CONTRACT CONSEQUENCES

In the case of a state contractor, contributions made or solicited in violation of the above prohibitions may result in the contract being voided.

In the case of a prospective state contractor, contributions made or solicited in violation of the above prohibitions shall result in the contract described in the state contract solicitation not being awarded to the prospective state contractor, unless the State Elections Enforcement Commission determines that mitigating circumstances exist concerning such violation.

The State shall not award any other state contract to anyone found in violation of the above prohibitions for a period of one year after the election for which such contribution is made or solicited, unless the State Elections Enforcement Commission determines that mitigating circumstances exist concerning such violation.

Additional information may be found on the website of the State Elections Enforcement Commission, [www.ct.gov/seec](http://www.ct.gov/seec). Click on the link to "Lobbyist/Contractor Limitations."



## DEFINITIONS

“State contractor” means a person, business entity or nonprofit organization that enters into a state contract. Such person, business entity or nonprofit organization shall be deemed to be a state contractor until December thirty-first of the year in which such contract terminates. “State contractor” does not include a municipality or any other political subdivision of the state, including any entities or associations duly created by the municipality or political subdivision exclusively amongst themselves to further any purpose authorized by statute or charter, or an employee in the executive or legislative branch of state government or a quasi-public agency, whether in the classified or unclassified service and full or part-time, and only in such person's capacity as a state or quasi-public agency employee.

“Prospective state contractor” means a person, business entity or nonprofit organization that (i) submits a response to a state contract solicitation by the state, a state agency or a quasi-public agency, or a proposal in response to a request for proposals by the state, a state agency or a quasi-public agency, until the contract has been entered into, or (ii) holds a valid prequalification certificate issued by the Commissioner of Administrative Services under section 4a-100. “Prospective state contractor” does not include a municipality or any other political subdivision of the state, including any entities or associations duly created by the municipality or political subdivision exclusively amongst themselves to further any purpose authorized by statute or charter, or an employee in the executive or legislative branch of state government or a quasi-public agency, whether in the classified or unclassified service and full or part-time, and only in such person's capacity as a state or quasi-public agency employee.

“Principal of a state contractor or prospective state contractor” means (i) any individual who is a member of the board of directors of, or has an ownership interest of five per cent or more in, a state contractor or prospective state contractor, which is a business entity, except for an individual who is a member of the board of directors of a nonprofit organization, (ii) an individual who is employed by a state contractor or prospective state contractor, which is a business entity, as president, treasurer or executive vice president, (iii) an individual who is the chief executive officer of a state contractor or prospective state contractor, which is not a business entity, or if a state contractor or prospective state contractor has no such officer, then the officer who duly possesses comparable powers and duties, (iv) an officer or an employee of any state contractor or prospective state contractor who has *managerial or discretionary responsibilities with respect to a state contract*, (v) the spouse or a *dependent child* who is eighteen years of age or older of an individual described in this subparagraph, or (vi) a political committee established or controlled by an individual described in this subparagraph or the business entity or nonprofit organization that is the state contractor or prospective state contractor.

“State contract” means an agreement or contract with the state or any state agency or any quasi-public agency, let through a procurement process or otherwise, having a value of fifty thousand dollars or more, or a combination or series of such agreements or contracts having a value of one hundred thousand dollars or more in a calendar year, for (i) the rendition of services, (ii) the furnishing of any goods, material, supplies, equipment or any items of any kind, (iii) the construction, alteration or repair of any public building or public work, (iv) the acquisition, sale or lease of any land or building, (v) a licensing arrangement, or (vi) a grant, loan or loan guarantee. “State contract” does not include any agreement or contract with the state, any state agency or any quasi-public agency that is exclusively federally funded, an education loan, a loan to an individual for other than commercial purposes or any agreement or contract between the state or any state agency and the United States Department of the Navy or the United States Department of Defense.

“State contract solicitation” means a request by a state agency or quasi-public agency, in whatever form issued, including, but not limited to, an invitation to bid, request for proposals, request for information or request for quotes, inviting bids, quotes or other types of submittals, through a competitive procurement process or another process authorized by law waiving competitive procurement.

“Managerial or discretionary responsibilities with respect to a state contract” means having direct, extensive and substantive responsibilities with respect to the negotiation of the state contract and not peripheral, clerical or ministerial responsibilities.

“Dependent child” means a child residing in an individual's household who may legally be claimed as a dependent on the federal income tax of such individual.

“Solicit” means (A) requesting that a contribution be made, (B) participating in any fund-raising activities for a candidate committee, exploratory committee, political committee or party committee, including, but not limited to, forwarding tickets to potential contributors, receiving contributions for transmission to any such committee or bundling contributions, (C) serving as chairperson, treasurer or deputy treasurer of any such committee, or (D) establishing a political committee for the sole purpose of soliciting or receiving contributions for any committee. Solicit does not include: (i) making a contribution that is otherwise permitted by Chapter 155 of the Connecticut General Statutes; (ii) informing any person of a position taken by a candidate for public office or a public official, (iii) notifying the person of any activities of, or contact information for, any candidate for public office; or (iv) serving as a member in any party committee or as an officer of such committee that is not otherwise prohibited in this section.

“Subcontractor” means any person, business entity or nonprofit organization that contracts to perform part or all of the obligations of a state contractor's state contract. Such person, business entity or nonprofit organization shall be deemed to be a subcontractor until December thirty first of the year in which the subcontract terminates. “Subcontractor” does not include (i) a municipality or any other political subdivision of the state, including any entities or associations duly created by the municipality or political subdivision exclusively amongst themselves to further any purpose authorized by statute or charter, or (ii) an employee in the executive or legislative branch of state government or a quasi-public agency, whether in the classified or unclassified service and full or part-time, and only in such person's capacity as a state or quasi-public agency employee.

“Principal of a subcontractor” means (i) any individual who is a member of the board of directors of, or has an ownership interest of five per cent or more in, a subcontractor, which is a business entity, except for an individual who is a member of the board of directors of a nonprofit organization, (ii) an individual who is employed by a subcontractor, which is a business entity, as president, treasurer or executive vice president, (iii) an individual who is the chief executive officer of a subcontractor, which is not a business entity, or if a subcontractor has no such officer, then the officer who duly possesses comparable powers and duties, (iv) an officer or an employee of any subcontractor who has managerial or discretionary responsibilities with respect to a subcontract with a state contractor, (v) the spouse or a dependent child who is eighteen years of age or older of an individual described in this subparagraph, or (vi) a political committee established or controlled by an individual described in this subparagraph or the business entity or nonprofit organization that is the subcontractor.

**EXHIBIT F**

General Decision Number: CT180001 10/19/2018 CT1

Superseded General Decision Number: CT20170001

State: Connecticut

Construction Type: Highway

Counties: Fairfield, Litchfield, Middlesex, New Haven, Tolland and Windham Counties in Connecticut.

HIGHWAY CONSTRUCTION PROJECTS

Note: Under Executive Order (EO) 13658, an hourly minimum wage of \$10.35 for calendar year 2018 applies to all contracts subject to the Davis-Bacon Act for which the contract is awarded (and any solicitation was issued) on or after January 1, 2015. If this contract is covered by the EO, the contractor must pay all workers in any classification listed on this wage determination at least \$10.35 per hour (or the applicable wage rate listed on this wage determination, if it is higher) for all hours spent performing on the contract in calendar year 2018. The EO minimum wage rate will be adjusted annually. Please note that this EO applies to the above-mentioned types of contracts entered into by the federal government that are subject to the Davis-Bacon Act itself, but it does not apply to contracts subject only to the Davis-Bacon Related Acts, including those set forth at 29 CFR 5.1(a)(2)-(60). Additional information on contractor requirements and worker protections under the EO is available at www.dol.gov/whd/govcontracts.

Modification Number	Publication Date
0	01/05/2018
1	01/12/2018
2	04/13/2018
3	05/18/2018
4	06/15/2018
5	06/22/2018
6	06/29/2018
7	07/06/2018
8	10/19/2018

BRCT0001-004 01/02/2018

Rates	Fringes
-------	---------

BRICKLAYER

BRICKLAYERS, CEMENT MASONS, CEMENT FINISHERS, PLASTERERS AND STONE MASONS.	\$ 33.48	31.66
--	----------	-------

CARP0326-003 05/07/2018

LITCHFIELD COUNTY

Harwinton, Plymouth, Thomaston, Watertown

MIDDLESEX COUNTY

NEW HAVEN COUNTY

Beacon Falls, Bethany, Branford, Cheshire, East Haven, Guilford, Hamden, Madison, Meriden, Middlebury, Naugatuck, New Haven, North Branford, North Haven, Orange (east of Orange Center Road and north of Route 1, and north of Route 1 and east of the Oyster River), Prospect, Southbury, Wallingford, Waterbury, West Haven, Wolcott, Woodbridge

TOLLAND COUNTY

Andover, Columbia, Coventry, Hebron, Mansfield, Union, Willington

WINDHAM COUNTY

Rates	Fringes
-------	---------

Carpenters:

CARPENTERS, PILEDRIVERS.....	\$ 32.60	25.34
DIVER TENDERS.....	\$ 32.60	25.34
DIVERS.....	\$ 41.06	25.34
MILLWRIGHTS.....	\$ 33.14	25.74

CARP0326-014 05/07/2018

Rates	Fringes
-------	---------

Carpenters: (TOLLAND COUNTY

Bolton, Ellington, Somers, Tolland, Vernon)

CARPENTERS, PILEDRIVERS.....	\$ 32.60	25.34
DIVER TENDERS.....	\$ 32.60	25.34
DIVERS.....	\$ 41.06	25.34
MILLWRIGHT.....	\$ 33.14	25.74

CARP0326-017 05/07/2018

Rates	Fringes
-------	---------

Carpenters:

CARPENTERS, PILEDRIVERS.....	\$ 32.60	25.34
DIVER TENDERS.....	\$ 32.60	25.34
DIVERS.....	\$ 41.06	25.34
MILLWRIGHTS.....	\$ 33.14	25.74

FAIRFIELD COUNTY

Bethel, Bridgeport, Brookfield, Danbury, Darien, Easton, Fairfield, Greenwich, Monroe, New Canaan, New Fairfield, Newtown, Norwalk, Redding, Ridgefield, Shelton, Sherman, Stamford, Stratford, Trumbull, Weston, Westport, Wilton;

LITCHFIELD COUNTY

Barkhamstead, Bethlehem, Bridgewater, Canaan, Colebrook, Cornwall, Goshen, Kent, Litchfield, Morris, New Hartford, New Milford, Norfolk, North Canaan, Roxbury, Salisbury, Sharon, Torrington, Warren, Washington, Winchester, Woodbury;

NEW HAVEN COUNTY

Ansonia, Derby, Milford, Orange (west of Orange Center Road and south of Route 1 and west of the Oyster River), Oxford, Seymour;

-----  
 ELEC0003-002 05/08/2008

	Rates	Fringes
Electricians		
FAIRFIELD COUNTY		
Darien, Greenwich, New Canaan, Stamford.....	\$ 44.75	30.42

-----  
 ELEC0035-001 06/01/2018

	Rates	Fringes
Electricians:		
MIDDLESEX COUNTY (Cromwell, Middlefield, Middleton and Portland); TOLLAND COUNTY; WINDHAM COUNTY.....	\$ 40.00	3%+25.97

-----  
 ELEC0090-002 06/01/2018

	Rates	Fringes
Electricians:.....	\$ 37.50	3%+27.91

LITCHFIELD COUNTY

Plymouth Township;

MIDDLESEX COUNTY

Chester, Clinton, Deep River, Durham, East Haddam, East Hampton, Essex, Haddam, Killingworth, Old Saybrook, Westbrook;

NEW HAVEN COUNTY

All Townships excluding Beacon Falls, Middlebury, Milford, Naugatuck, Oxford, Prospect, Seymour, Southbury, Waterbury and Wolcott.

-----  
 ELEC0488-002 06/01/2018

	Rates	Fringes
Electricians.....	\$ 38.82	3%+26.25

FAIRFIELD COUNTY

Bethel, Bridgeport, Brookfield, Danbury, Easton, Fairfield, Monroe, New Fairfield, Newtown, Norwalk, Redding, Ridgefield, Shelton, Sherman, Stratford, Trumbull, Weston, Westport and Wilton.

LITCHFIELD COUNTY

Except Plymouth;

NEW HAVEN COUNTY

Beacon Falls, Middlebury, Milford, Naugatuck, Oxford, Prospect, Seymour, Southbury, Waterbury and Wolcott

-----  
 \* ENGI0478-001 09/30/2018

	Rates	Fringes
Power equipment operators:		
GROUP 1.....	\$ 39.55	24.30
GROUP 2.....	\$ 39.23	24.30
GROUP 3.....	\$ 38.49	24.30
GROUP 4.....	\$ 38.10	24.30
GROUP 5.....	\$ 37.51	24.30
GROUP 6.....	\$ 37.20	24.30
GROUP 7.....	\$ 36.86	24.30
GROUP 8.....	\$ 36.46	24.30
GROUP 9.....	\$ 36.03	24.30
GROUP 10.....	\$ 33.99	24.30
GROUP 11.....	\$ 33.99	24.30
GROUP 12.....	\$ 33.93	24.30
GROUP 13.....	\$ 35.46	24.30
GROUP 14.....	\$ 33.35	24.30
GROUP 15.....	\$ 33.04	24.30
GROUP 16.....	\$ 32.21	24.30
GROUP 17.....	\$ 31.80	24.30
GROUP 18.....	\$ 31.15	24.30

Hazardous waste premium \$3.00 per hour over classified rate.

Crane with boom, including jib, 150 feet - \$1.50 extra.  
 Crane with boom, including jib, 200 feet - \$2.50 extra.  
 Crane with boom, including jib, 250 feet - \$5.00 extra.  
 Crane with boom, including jib, 300 feet - \$7.00 extra.  
 Crane with boom, including jib, 400 feet - \$10.00 extra

All Cranes: When crane operator is operating equipment that requires a fully licensed crane operator to operate he

receives an extra \$4.00 premium in addition to the hourly wage rate and benefit contributions:

- 1) Crane handling or erecting structural steel or stone, hoisting engineer(2 drums or over)
- 2) Cranes(100 ton rated capacity and over) Bauer Drill/Caisson
- 3) Cranes(under 100 ton rated capacity)

a. PAID HOLIDAYS: New Year's Day, Good Friday, Memorial Day, Independence Day, Labor Day, Thanksgiving Day and Christmas Day, provided the employee works 3 days during the week in which the holiday falls, if scheduled, and if scheduled, the working day before and the working day after the holiday.

POWER EQUIPMENT OPERATORS CLASSIFICATIONS

GROUP 1: Crane handling or erecting structural steel or stone, hoisting engineer (2 drums or over), front end loader (7 cubic yards or over), work boat 26 ft. and over.

GROUP 2: Cranes (100 ton capacity & over), Excavator over 2 cubic yards, piledriver (\$3.00 premium when operator controls hammer), Bauer Drill/Caisson

GROUP 3: Excavator, cranes (under 100 ton rated capacity), gradall, master mechanic, hoisting engineer (all types of equipment where a drum and cable are used to hoist or drag material regardless of motive power or operation) Rubber Tire Excavator (drott 1085 or similar); Grader Operator; Bulldozer Fine Grade (slopes, shaping, laser or GPS, etc.)

GROUP 4: Trenching machines, lighter derrick, concrete finishing machine, CMI machine or similar, Koehring Loader (skoooper).

GROUP 5: Specialty railroad equipment, asphalt spreader, asphalt reclaiming machine, line grider, concrete pumps, drills with self contained power units, boring machine, post hole digger, auger, pounder, well digger, milling machine (over 24' mandrel), side boom, combination hoe and loader, directional driller

GROUP 6: Front end loader (3 cu. yds. up to 7 cu. yards), bulldozer (Rough grade dozer) .

GROUP 7: Asphalt roller, concrete saws and cutters (ride on types), Vermeer concrete cutter, stump grinder, scraper, snooper, skidder, milling machine (24" and under Mandrel).

GROUP 8: Mechanic, grease truck operator, hydoblaster, barrier mover, power stone spreader, welder, work boat under 26 ft. transfer machine.

GROUP 9: Front end loader (under 3 cubic yards), skid steer loader (regardless of attachments), bobcat or similar, forklift, power chipper, landscape equipment (including hydroseeder).

GROUP 10: Vibratory hammer, ice machine, diesel & air, hammer, etc.

GROUP 11: Conveyor, earth roller, power pavement breaker (whiphammer), robot demolition equipment.

GROUP 12: Wellpoint operator.

GROUP 13: Portable asphalt plant operator, portable concrete plant operator, portable crusher plant operator.

GROUP 14: Compressor battery operator.

GROUP 15: Power Safety boat, Vacuum truck, Zim mixer, Sweeper; (Minimum for any job requiring a CDL license) .

GROUP 16: Elevator operator, tow motor operator (solid tire no rough terrain).

GROUP 17: Generator operator, compressor operator, pump operator, welding machine operator; Heater operator.

GROUP 18: Maintenance engineer.

-----  
IRON0015-002 06/30/2018

	Rates	Fringes
Ironworkers: (Reinforcing, Structural and Precast Concrete Erection).....	\$ 35.47	35.14

a. PAID HOLIDAY: Labor Day provided employee has been on the payroll for the 5 consecutive work days prior to Labor Day.

-----  
LAB00056-003 04/01/2018

	Rates	Fringes
Laborers:		
GROUP 1.....	\$ 30.05	19.84
GROUP 2.....	\$ 30.30	19.84
GROUP 3.....	\$ 30.55	19.84
GROUP 4.....	\$ 31.05	19.84
GROUP 5.....	\$ 31.80	19.84
GROUP 6.....	\$ 32.05	19.84
GROUP 7.....	\$ 16.00	19.84

LABORERS CLASSIFICATIONS

GROUP 1: Laborers (Unskilled), acetylene burner, concrete specialist

GROUP 2: Chain saw operators, fence and guard rail erectors, pneumatic tool operators and powdermen.

GROUP 3: Pipelayers, Jackhammer/Pavement breaker (handheld), mason tenders/catch basin builders, asphalt rakers, air track operators, block paver and curb setter

GROUP 4: Asbestos/lead removal

GROUP 5: Blasters

GROUP 6: Toxic waste remover

GROUP 7: Traffic control signalman

-----  
LAB0056-004 04/01/2018

	Rates	Fringes
Laborers: (TUNNEL CONSTRUCTION)		
CLEANING, CONCRETE AND CAULKING TUNNEL:		
Concrete Workers, Form Movers and Strippers.....	\$ 31.28	19.84
Form Erectors.....	\$ 31.60	19.84
ROCK SHAFT, CONCRETE, LINING OF SAME AND TUNNEL IN FREE AIR:		
Brakemen, Trackmen, Tunnel Laborers, Shaft Laborers.....	\$ 31.28	19.84
Laborers Topside, Cage Tenders, Bellman.....	\$ 31.17	19.84
Miners.....	\$ 32.22	19.84
SHIELD DRIVE AND LINER PLATE TUNNELS IN FREE AIR:		
Brakemen and Trackmen.....	\$ 31.28	19.84
Miners, Motormen, Mucking Machine Operators, Nozzlemen, Grout Men, Shaft and Tunnel, Steel and Rodmen, Shield and Erector, Arm Operator, Cable Tenders.....	\$ 32.22	19.84
TUNNELS, CAISSON AND CYLINDER WORK IN COMPRESSED AIR:		
Blaster.....	\$ 38.53	19.84
Brakemen, Trackmen, Groutman, Laborers, Outside Lock Tender, Gauge Tenders.....	\$ 38.34	19.84
Change House Attendants, Powder Watchmen, Top on Iron Bolts.....	\$ 36.41	19.84
Mucking Machine Operator...\$	39.11	19.84

a. PAID HOLIDAYS: On tunnel work only: New Year's Day, Memorial Day, Independence Day, Labor Day, Thanksgiving Day and Christmas Day.

No employee shall be eligible for holiday pay when he fails, without cause, to work the regular work day preceding the holiday or the regular work day following the holiday.

-----  
PAIN0011-001 06/01/2018

	Rates	Fringes
Painters:		
Blast and Spray.....	\$ 36.62	21.05
Brush and Roll.....	\$ 33.62	21.05
Tanks, Towers, Swing.....	\$ 35.62	21.05

-----  
PAIN0011-003 06/01/2018

	Rates	Fringes
Painters: (BRIDGE CONSTRUCTION)		
Brush, Roller, Blasting (Sand, Water, etc.) Spray...\$	49.75	21.05

-----  
TEAM0064-001 04/01/2018

	Rates	Fringes
Truck drivers:		
2 Axle Ready Mix.....	\$ 29.23	23.33
2 Axle.....	\$ 29.13	23.33
3 Axle Ready Mix.....	\$ 29.28	23.33
3 Axle.....	\$ 29.23	23.33
4 Axle Ready Mix.....	\$ 29.38	23.33
4 Axle.....	\$ 29.33	23.33
Heavy Duty Trailer 40 tons and over.....	\$ 29.58	23.33
Heavy Duty Trailer up to 40 tons.....	\$ 29.33	23.33

Specialized (Earth moving equipment other than conventional type on-the-road trucks and semi-trailers, including Euclids).....\$ 29.38            23.33

Hazardous waste removal work receives additional \$1.25 per hour.

a. PAID HOLIDAYS: New Year's Day, Memorial Day, Independence Day, Labor Day, Thanksgiving Day, Christmas Day and Good Friday, provided the employee has at least 31 calendar days of service and works the last scheduled day before and the first scheduled day after the holiday, unless excused.

-----  
WELDERS - Receive rate prescribed for craft performing operation to which welding is incidental.  
=====

Note: Executive Order (EO) 13706, Establishing Paid Sick Leave for Federal Contractors applies to all contracts subject to the Davis-Bacon Act for which the contract is awarded (and any solicitation was issued) on or after January 1, 2017. If this contract is covered by the EO, the contractor must provide employees with 1 hour of paid sick leave for every 30 hours they work, up to 56 hours of paid sick leave each year. Employees must be permitted to use paid sick leave for their own illness, injury or other health-related needs, including preventive care; to assist a family member (or person who is like family to the employee) who is ill, injured, or has other health-related needs, including preventive care; or for reasons resulting from, or to assist a family member (or person who is like family to the employee) who is a victim of, domestic violence, sexual assault, or stalking. Additional information on contractor requirements and worker protections under the EO is available at [www.dol.gov/whd/govcontracts](http://www.dol.gov/whd/govcontracts).

Unlisted classifications needed for work not included within the scope of the classifications listed may be added after award only as provided in the labor standards contract clauses (29CFR 5.5 (a) (1) (ii)).

-----  
The body of each wage determination lists the classification and wage rates that have been found to be prevailing for the cited type(s) of construction in the area covered by the wage determination. The classifications are listed in alphabetical order of "identifiers" that indicate whether the particular rate is a union rate (current union negotiated rate for local), a survey rate (weighted average rate) or a union average rate (weighted union average rate).

#### Union Rate Identifiers

A four letter classification abbreviation identifier enclosed in dotted lines beginning with characters other than "SU" or "UAVG" denotes that the union classification and rate were prevailing for that classification in the survey. Example: PLUM0198-005 07/01/2014. PLUM is an abbreviation identifier of the union which prevailed in the survey for this classification, which in this example would be Plumbers. 0198 indicates the local union number or district council number where applicable, i.e., Plumbers Local 0198. The next number, 005 in the example, is an internal number used in processing the wage determination. 07/01/2014 is the effective date of the most current negotiated rate, which in this example is July 1, 2014.

Union prevailing wage rates are updated to reflect all rate changes in the collective bargaining agreement (CBA) governing this classification and rate.

#### Survey Rate Identifiers

Classifications listed under the "SU" identifier indicate that no one rate prevailed for this classification in the survey and the published rate is derived by computing a weighted average rate based on all the rates reported in the survey for that classification. As this weighted average rate includes all rates reported in the survey, it may include both union and non-union rates. Example: SULA2012-007 5/13/2014. SU indicates the rates are survey rates based on a weighted average calculation of rates and are not majority rates. LA indicates the State of Louisiana. 2012 is the year of survey on which these classifications and rates are based. The next number, 007 in the example, is an internal number used in producing the wage determination. 5/13/2014 indicates the survey completion date for the classifications and rates under that identifier.

Survey wage rates are not updated and remain in effect until a new survey is conducted.

#### Union Average Rate Identifiers

Classification(s) listed under the UAVG identifier indicate that no single majority rate prevailed for those classifications; however, 100% of the data reported for the classifications was union data. EXAMPLE: UAVG-OH-0010 08/29/2014. UAVG indicates that the rate is a weighted union average rate. OH indicates the state. The next number, 0010 in the example, is an internal number used in producing the wage

determination. 08/29/2014 indicates the survey completion date for the classifications and rates under that identifier.

A UAVG rate will be updated once a year, usually in January of each year, to reflect a weighted average of the current negotiated/CBA rate of the union locals from which the rate is based.

-----  
WAGE DETERMINATION APPEALS PROCESS

1.) Has there been an initial decision in the matter? This can be:

- \* an existing published wage determination
- \* a survey underlying a wage determination
- \* a Wage and Hour Division letter setting forth a position on a wage determination matter
- \* a conformance (additional classification and rate) ruling

On survey related matters, initial contact, including requests for summaries of surveys, should be with the Wage and Hour Regional Office for the area in which the survey was conducted because those Regional Offices have responsibility for the Davis-Bacon survey program. If the response from this initial contact is not satisfactory, then the process described in 2.) and 3.) should be followed.

With regard to any other matter not yet ripe for the formal process described here, initial contact should be with the Branch of Construction Wage Determinations. Write to:

Branch of Construction Wage Determinations  
Wage and Hour Division  
U.S. Department of Labor  
200 Constitution Avenue, N.W.  
Washington, DC 20210

2.) If the answer to the question in 1.) is yes, then an interested party (those affected by the action) can request review and reconsideration from the Wage and Hour Administrator (See 29 CFR Part 1.8 and 29 CFR Part 7). Write to:

Wage and Hour Administrator  
U.S. Department of Labor  
200 Constitution Avenue, N.W.  
Washington, DC 20210

The request should be accompanied by a full statement of the interested party's position and by any information (wage payment data, project description, area practice material, etc.) that the requestor considers relevant to the issue.

3.) If the decision of the Administrator is not favorable, an interested party may appeal directly to the Administrative Review Board (formerly the Wage Appeals Board). Write to:

Administrative Review Board  
U.S. Department of Labor  
200 Constitution Avenue, N.W.  
Washington, DC 20210

4.) All decisions by the Administrative Review Board are final.

=====  
END OF GENERAL DECISION



**EXHIBIT G**

Project: Rubber Avenue At Hoadley Street And Melbourne Street Traffic Signal Replacement

**Minimum Rates and Classifications  
for Heavy/Highway Construction**

**Connecticut Department of Labor  
Wage and Workplace Standards Division**

ID#: H 25524

By virtue of the authority vested in the Labor Commissioner under provisions of Section 31-53 of the General Statutes of Connecticut, as amended, the following are declared to be the prevailing rates and welfare payments and will apply only where the contract is advertised for bid within 20 days of the date on which the rates are established. Any contractor or subcontractor not obligated by agreement to pay to the welfare and pension fund shall pay this amount to each employee as part of his/her hourly wages.

Project Number: 87-146

Project Town: Naugatuck

FAP Number: 1087(113)

State Number:

Project: Rubber Avenue At Hoadley Street And Melbourne Street Traffic Signal Replacement

**CLASSIFICATION**

**Hourly Rate**

**Benefits**

01) Asbestos/Toxic Waste Removal Laborers: Asbestos removal and encapsulation (except its removal from mechanical systems which are not to be scrapped), toxic waste removers, blasters. \*\*See Laborers Group 5 and 7\*\*

---

1) Boilermaker	33.79	34% + 8.96
----------------	-------	------------

---

1a) Bricklayer, Cement Masons, Cement Finishers, Plasterers, Stone Masons	33.48	31.66
---	-------	-------

---

2) Carpenters, Piledrivermen	32.60	25.34
------------------------------	-------	-------

---

As of:

Friday, January 04, 2019

Project: Rubber Avenue At Hoadley Street And Melbourne Street Traffic Signal Replacement

2a) Diver Tenders	32.60	25.34
-------------------	-------	-------

---

3) Divers	41.06	25.34
-----------	-------	-------

---

03a) Millwrights	33.14	25.74
------------------	-------	-------

---

4) Painters: (Bridge Construction) Brush, Roller, Blasting (Sand, Water, etc.), Spray	49.75	21.05
--	-------	-------

---

4a) Painters: Brush and Roller	33.62	21.05
--------------------------------	-------	-------

---

4b) Painters: Spray Only	36.62	21.05
--------------------------	-------	-------

---

4c) Painters: Steel Only	35.62	21.05
--------------------------	-------	-------

---

*As of:*

Friday, January 04, 2019

Project: Rubber Avenue At Hoadley Street And Melbourne Street Traffic Signal Replacement

4d) Painters: Blast and Spray 36.62 21.05

---

4e) Painters: Tanks, Tower and Swing 35.62 21.05

---

5) Electrician (Trade License required: E-1,2 L-5,6 C-5,6 T-1,2 L-1,2 V-1,2,7,8,9) 38.82 26.25+3% of gross wage

---

6) Ironworkers: Ornamental, Reinforcing, Structural, and Precast Concrete Erection 35.47 35.14 + a

---

7) Plumbers (Trade License required: (P-1,2,6,7,8,9 J-1,2,3,4 SP-1,2) and Pipefitters (Including HVAC Work) (Trade License required: S-1,2,3,4,5,6,7,8 B-1,2,3,4 D-1,2,3,4 G-1, G-2, G-8, G-9) 42.62 31.21

---

---LABORERS----

---

8) Group 1: Laborer (Unskilled), Common or General, acetylene burner, concrete specialist 30.05 20.10

---

As of:

Friday, January 04, 2019

Project: Rubber Avenue At Hoadley Street And Melbourne Street Traffic Signal Replacement

9) Group 2: Chain saw operators, fence and guard rail erectors, pneumatic tool operators, powdermen	30.30	20.10
---	-------	-------

---

10) Group 3: Pipelayers	30.55	20.10
-------------------------	-------	-------

---

11) Group 4: Jackhammer/Pavement breaker (handheld); mason tenders (cement/concrete), catch basin builders, asphalt rakers, air track operators, block paver, curb setter and forklift operators	30.55	20.10
--	-------	-------

---

12) Group 5: Toxic waste removal (non-mechanical systems)	32.05	20.10
---	-------	-------

---

13) Group 6: Blasters	31.80	20.10
-----------------------	-------	-------

---

Group 7: Asbestos/lead removal, non-mechanical systems (does not include leaded joint pipe)	31.05	20.10
---	-------	-------

---

Group 8: Traffic control signalmen	16.00	20.10
------------------------------------	-------	-------

---

Project: Rubber Avenue At Hoadley Street And Melbourne Street Traffic Signal Replacement

Group 9: Hydraulic Drills	29.30	18.90
---------------------------	-------	-------

---

---LABORERS (TUNNEL CONSTRUCTION, FREE AIR). Shield Drive and  
Liner Plate Tunnels in Free Air.---

---

13a) Miners, Motormen, Mucking Machine Operators, Nozzle Men, Grout Men, Shaft & Tunnel Steel & Rodmen, Shield & Erector, Arm Operator, Cable Tenders	32.22	20.10 + a
---	-------	-----------

---

13b) Brakemen, Trackmen	31.28	20.10 + a
-------------------------	-------	-----------

---

---CLEANING, CONCRETE AND CAULKING TUNNEL---

---

14) Concrete Workers, Form Movers, and Strippers	31.28	20.10 + a
--	-------	-----------

---

15) Form Erectors	31.60	20.10 + a
-------------------	-------	-----------

---

*As of:*

Friday, January 04, 2019

Project: Rubber Avenue At Hoadley Street And Melbourne Street Traffic Signal Replacement

---ROCK SHAFT LINING, CONCRETE, LINING OF SAME AND TUNNEL  
IN FREE AIR:----

---

16) Brakemen, Trackmen, Tunnel Laborers, Shaft Laborers	31.28	20.10 + a
---	-------	-----------

---

17) Laborers Topside, Cage Tenders, Bellman	31.17	20.10 + a
---	-------	-----------

---

18) Miners	32.22	20.10 + a
------------	-------	-----------

---

---TUNNELS, CAISSON AND CYLINDER WORK IN COMPRESSED  
AIR: ----

---

18a) Blaster	38.53	20.10 + a
--------------	-------	-----------

---

19) Brakemen, Trackmen, Groutman, Laborers, Outside Lock Tender, Gauge Tenders	38.34	20.10 + a
---	-------	-----------

---

*As of:*

Friday, January 04, 2019

Project: Rubber Avenue At Hoadley Street And Melbourne Street Traffic Signal Replacement

20) Change House Attendants, Powder Watchmen, Top on Iron Bolts	36.41	20.10 + a
---	-------	-----------

---

21) Mucking Machine Operator	39.11	20.10 + a
------------------------------	-------	-----------

---

---TRUCK DRIVERS---(\*see note below)

---

Two axle trucks	29.13	23.33 + a
-----------------	-------	-----------

---

Three axle trucks; two axle ready mix	29.23	23.33 + a
---------------------------------------	-------	-----------

---

Three axle ready mix	29.28	23.33 + a
----------------------	-------	-----------

---

Four axle trucks, heavy duty trailer (up to 40 tons)	29.33	23.33 + a
--	-------	-----------

---

*As of:*

Friday, January 04, 2019



Project: Rubber Avenue At Hoadley Street And Melbourne Street Traffic Signal Replacement

Four axle ready-mix	29.38	23.33 + a
<hr/>		
Heavy duty trailer (40 tons and over)	29.58	23.33 + a
<hr/>		
Specialized earth moving equipment other than conventional type on-the road trucks and semi-trailer (including Euclids)	29.38	23.33 + a
<hr/>		
---POWER EQUIPMENT OPERATORS---		
<hr/>		
Group 1: Crane handling or erecting structural steel or stone, hoisting engineer (2 drums or over), front end loader (7 cubic yards or over), Work Boat 26 ft. & Over, Tunnel Boring Machines. (Trade License Required)	39.55	24.30 + a
<hr/>		
Group 2: Cranes (100 ton rate capacity and over); Excavator over 2 cubic yards; Piledriver (\$3.00 premium when operator controls hammer); Bauer Drill/Caisson. (Trade License Required)	39.23	24.30 + a
<hr/>		
Group 3: Excavator/Backhoe under 2 cubic yards; Cranes (under 100 ton rated capacity), Gradall; Master Mechanic; Hoisting Engineer (all types of equipment where a drum and cable are used to hoist or drag material regardless of motive power of operation), Rubber Tire Excavator (Drott-1085 or similar); Grader Operator; Bulldozer Fine Grade (slopes, shaping, laser or GPS, etc.). (Trade License Required)	38.49	24.30 + a
<hr/>		

As of:

Friday, January 04, 2019

Project: Rubber Avenue At Hoadley Street And Melbourne Street Traffic Signal Replacement

Group 4: Trenching Machines; Lighter Derrick; Concrete Finishing Machine; CMI Machine or Similar; Koehring Loader (Skooper) 38.10 24.30 + a

---

Group 5: Specialty Railroad Equipment; Asphalt Paver; Asphalt Spreader; Asphalt Reclaiming Machine; Line Grinder; Concrete Pumps; Drills with Self Contained Power Units; Boring Machine; Post Hole Digger; Auger; Pounder; Well Digger; Milling Machine (over 24" Mandrell) 37.51 24.30 + a

---

Group 5 continued: Side Boom; Combination Hoe and Loader; Directional Driller. 37.51 24.30 + a

---

Group 6: Front End Loader (3 up to 7 cubic yards); Bulldozer (rough grade dozer). 37.20 24.30 + a

---

Group 7: Asphalt Roller; Concrete Saws and Cutters (ride on types); Vermeer Concrete Cutter; Stump Grinder; Scraper; Snooper; Skidder; Milling Machine (24" and Under Mandrel). 36.86 24.30 + a

---

Group 8: Mechanic, Grease Truck Operator, Hydroblaster, Barrier Mover, Power Stone Spreader; Welder; Work Boat under 26 ft.; Transfer Machine. 36.46 24.30 + a

---

Group 9: Front End Loader (under 3 cubic yards), Skid Steer Loader regardless of attachments (Bobcat or Similar); Fork Lift, Power Chipper; Landscape Equipment (including hydroseeder). 36.03 24.30 + a

---

Project: Rubber Avenue At Hoadley Street And Melbourne Street Traffic Signal Replacement

Group 10: Vibratory Hammer, Ice Machine, Diesel and Air Hammer, etc. 33.99 24.30 + a

---

Group 11: Conveyor, Earth Roller; Power Pavement Breaker (whiphammer), Robot Demolition Equipment. 33.99 24.30 + a

---

Group 12: Wellpoint Operator. 33.93 24.30 + a

---

Group 13: Compressor Battery Operator. 33.35 24.30 + a

---

Group 14: Elevator Operator; Tow Motor Operator (Solid Tire No Rough Terrain). 32.21 24.30 + a

---

Group 15: Generator Operator; Compressor Operator; Pump Operator; Welding Machine Operator; Heater Operator. 31.80 24.30 + a

---

Group 16: Maintenance Engineer/Oiler 31.15 24.30 + a

---

*As of:*

Friday, January 04, 2019

Project: Rubber Avenue At Hoadley Street And Melbourne Street Traffic Signal Replacement

Group 17: Portable asphalt plant operator; portable crusher plant operator; portable concrete plant operator.	35.46	24.30 + a
---	-------	-----------

---

Group 18: Power Safety Boat; Vacuum Truck; Zim Mixer; Sweeper; (minimum for any job requiring CDL license).	33.04	24.30 + a
---	-------	-----------

---

\*\*NOTE: SEE BELOW

---

---LINE CONSTRUCTION---(Railroad Construction and Maintenance)---

---

20) Lineman, Cable Splicer, Technician	48.19	6.5% + 22.00
--	-------	--------------

---

21) Heavy Equipment Operator	42.26	6.5% + 19.88
------------------------------	-------	--------------

---

22) Equipment Operator, Tractor Trailer Driver, Material Men	40.96	6.5% + 19.21
--	-------	--------------

---

*As of:*

Friday, January 04, 2019

Project: Rubber Avenue At Hoadley Street And Melbourne Street Traffic Signal Replacement

23) Driver Groundmen	26.50	6.5% + 9.00
----------------------	-------	-------------

---

23a) Truck Driver	40.96	6.5% + 17.76
-------------------	-------	--------------

---

---LINE CONSTRUCTION---

---

24) Driver Groundmen	30.92	6.5% + 9.70
----------------------	-------	-------------

---

25) Groundmen	22.67	6.5% + 6.20
---------------	-------	-------------

---

26) Heavy Equipment Operators	37.10	6.5% + 10.70
-------------------------------	-------	--------------

---

27) Linemen, Cable Splicers, Dynamite Men	41.22	6.5% + 12.20
---	-------	--------------

---

*As of:*

Friday, January 04, 2019

Project: Rubber Avenue At Hoadley Street And Melbourne Street Traffic Signal Replacement

28) Material Men, Tractor Trailer Drivers, Equipment Operators 35.04 6.5% + 10.45

---

Project: Rubber Avenue At Hoadley Street And Melbourne Street Traffic Signal Replacement

*Welders: Rate for craft to which welding is incidental.*

*\*Note: Hazardous waste removal work receives additional \$1.25 per hour for truck drivers.*

*\*\*Note: Hazardous waste premium \$3.00 per hour over classified rate*

***ALL Cranes: When crane operator is operating equipment that requires a fully licensed crane operator to operate he receives an extra \$4.00 premium in addition to the hourly wage rate and benefit contributions:***

***1) Crane handling or erecting structural steel or stone; hoisting engineer (2 drums or over)***

***2) Cranes (100 ton rate capacity and over) Bauer Drill/Caisson***

***3) Cranes (under 100 ton rated capacity)***

*Crane with 150 ft. boom (including jib) - \$1.50 extra*

*Crane with 200 ft. boom (including jib) - \$2.50 extra*

*Crane with 250 ft. boom (including jib) - \$5.00 extra*

*Crane with 300 ft. boom (including jib) - \$7.00 extra*

*Crane with 400 ft. boom (including jib) - \$10.00 extra*

All classifications that indicate a percentage of the fringe benefits must be calculated at the percentage rate times the "base hourly rate".

Apprentices duly registered under the Commissioner of Labor's regulations on "Work Training Standards for Apprenticeship and Training Programs" Section 31-51-d-1 to 12, are allowed to be paid the appropriate percentage of the prevailing journeymen hourly base and the full fringe benefit rate, providing the work site ratio shall not be less than one full-time journeyman instructing and supervising the work of each apprentice in a specific trade.

*~~Connecticut General Statute Section 31-55a: Annual Adjustments to wage rates by contractors doing state work ~~*

*The Prevailing wage rates applicable to this project are subject to annual adjustments each July 1st for the duration of the project.*

*Each contractor shall pay the annual adjusted prevailing wage rate that is in effect each July 1st, as posted by the Department of Labor.*

*It is the contractor's responsibility to obtain the annual adjusted prevailing wage rate increases directly from the Department of Labor's website.*

*The annual adjustments will be posted on the Department of Labor's Web page: [www.ct.gov/dol](http://www.ct.gov/dol).*

*The Department of Labor will continue to issue the initial prevailing wage rate schedule to the Contracting Agency for the project.*

*All subsequent annual adjustments will be posted on our Web Site for contractor access.*

*Contracting Agencies are under no obligation pursuant to State labor law to pay any increase due to the annual adjustment provision.*

As of:

Friday, January 04, 2019

Project: Rubber Avenue At Hoadley Street And Melbourne Street Traffic Signal Replacement

*Effective October 1, 2005 - Public Act 05-50: any person performing the work of any mechanic, laborer, or worker shall be paid prevailing wage*

All Person who perform work ON SITE must be paid prevailing wage for the appropriate mechanic, laborer, or worker classification.

All certified payrolls must list the hours worked and wages paid to All Persons who perform work ON SITE regardless of their ownership i.e.: (Owners, Corporate Officers, LLC Members, Independent Contractors, et. al)

Reporting and payment of wages is required regardless of any contractual relationship alleged to exist between the contractor and such person.

**~~Unlisted classifications needed for work not included within the scope of the classifications listed may be added after award only as provided in the labor standards contract clause (29 CFR 5.5 (a) (1) (ii)).**

Please direct any questions which you may have pertaining to classification of work and payment of prevailing wages to the Wage and Workplace Standards Division, telephone (860)263-6790.

*As of:*

Friday, January 04, 2019