

Borough of Naugatuck

City Hill Middle School Photovoltaic Project

441 City Hill Street
Naugatuck, Connecticut 06770

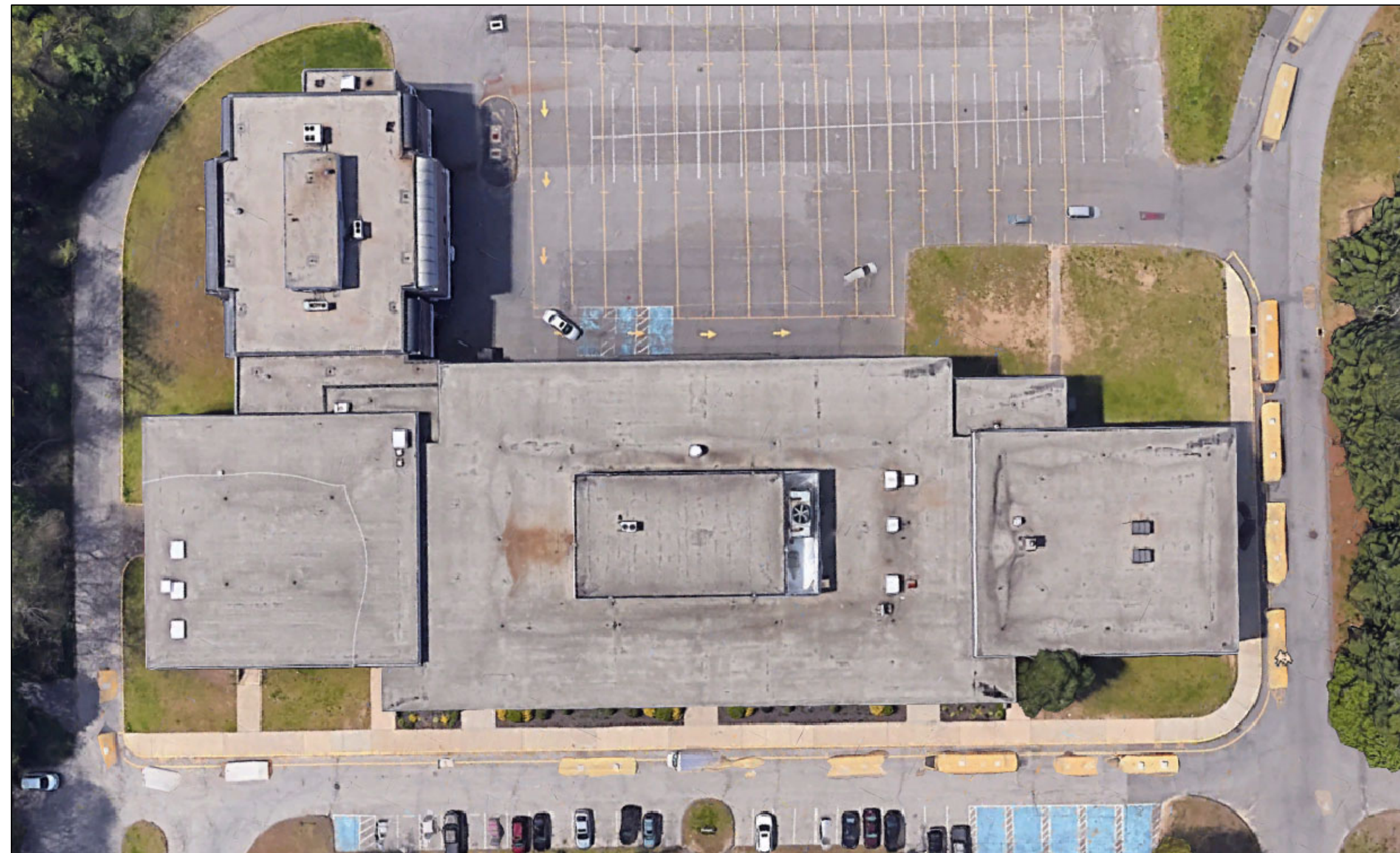

DRAWING LIST:

- Cover Sheet
- E1 Electrical Roof
Plan, Details & Notes
- E2 One-Line Diagram

SITE LOCATION MAP

scale: NONE

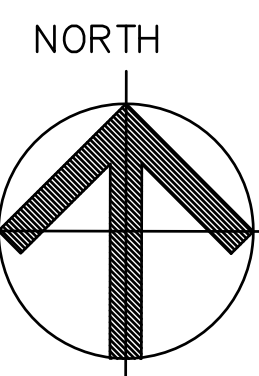

SILVER / PETRUCELLI + ASSOCIATES

Architects / Engineers / Interior Designers

3190 Whitney Avenue, Hamden, CT 06518
One Post Hill Place, New London, CT 06320
Tel. 203 230 9007 Fax. 203 230 8247
silverpetrucelli.com

State Project # 088-0075 PV

October 4, 2019

Issued for Bid: July 9, 2020

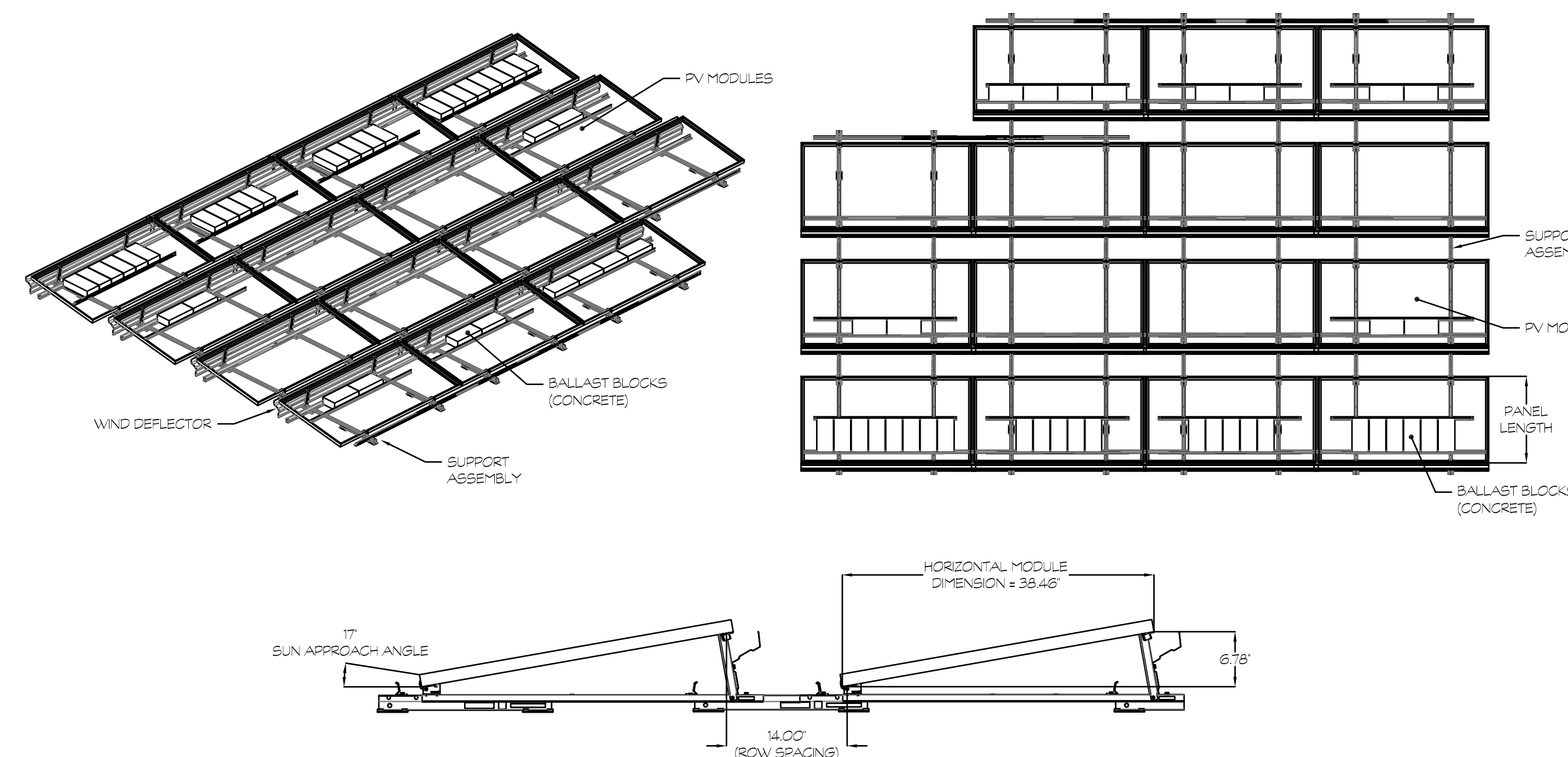
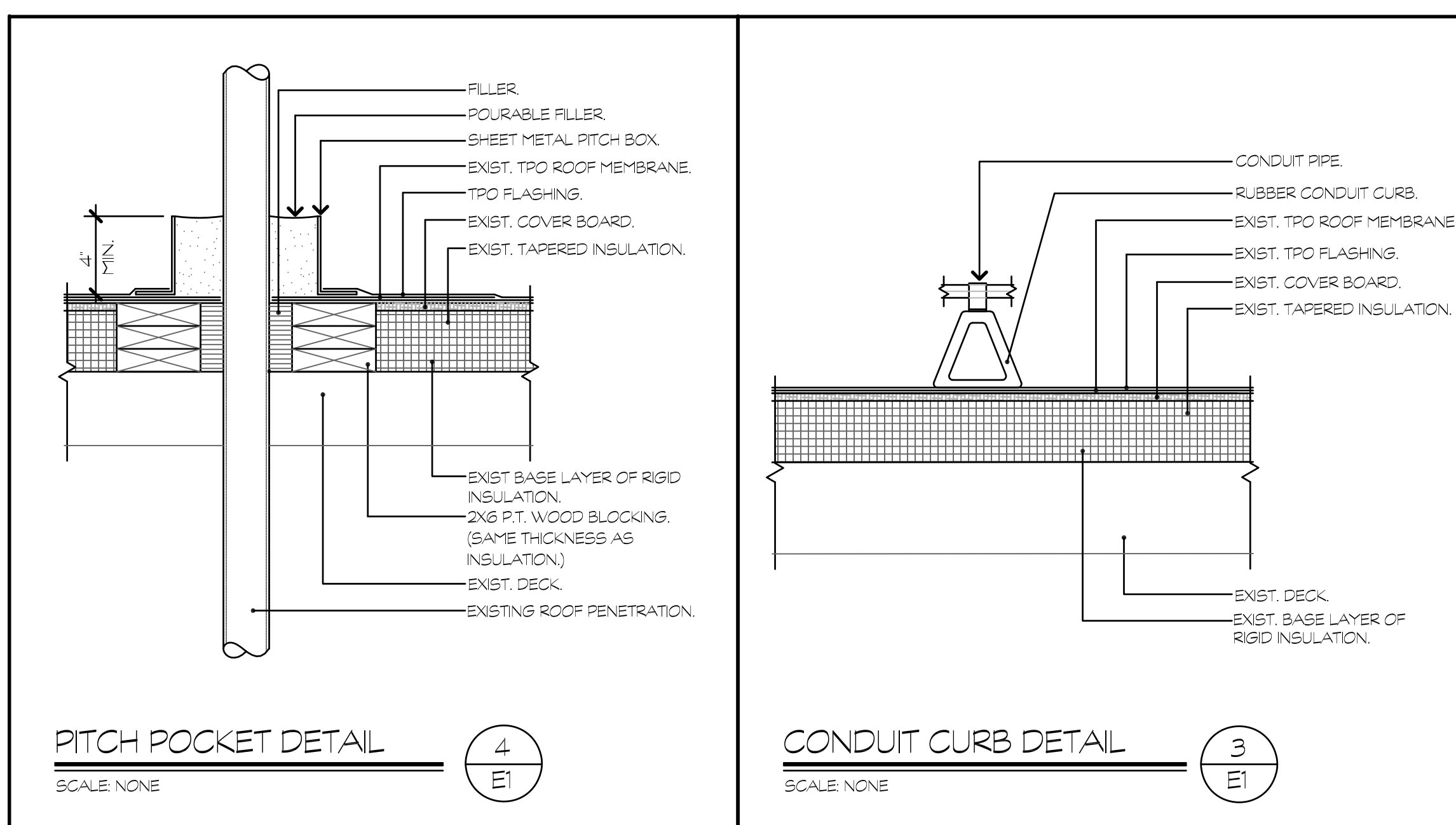

- NOTES: UNLESS OTHERWISE SPECIFIED
- THIS DRAWING IS FOR LAYOUT REFERENCE ONLY.
 - ALL STAINLESS STEEL HARDWARE.
 - ALL DIMENSIONS ARE IN INCHES.
 - VERIFY REQUIRED BALLAST IS ACQUIRED BLOCK SIZES SHOULD BE 2'x8'x8", 3'x8'x8" OR 4'x8'x8" (3000 PSI).
 - CONFIRM DIMENSIONS REQUIRED & ADJUST AS REQUIRED FOR EXACT SPECS OF SUBMITTED EQUIPMENT.
 - ROW-ROW GAP = 14".
 - N/S REPEAT = 82".
 - E-W REPEAT = MODULE WIDTH + 75".

- GENERAL NOTES - ELECTRICAL**
- SPECIFICATION SECTIONS, GENERAL CONDITIONS, SUPPLEMENTAL GENERAL CONDITIONS AND DRAWINGS ARE INTEGRAL PARTS OF CONTRACT DOCUMENTS.
 - SYSTEM COMPONENTS ARE LOCATED APPROXIMATELY ON DRAWINGS. BASE ACTUAL LOCATIONS ON FIELD VERIFICATION OF EXISTING BUILDING CHARACTERISTICS INCLUDING BUT NOT LIMITED TO STRUCTURAL, MECHANICAL, ELECTRICAL & ARCHITECTURAL COMPONENTS.
 - ALL WORK AND ACTION DERIVED AND DESCRIBED IN CONTRACT DOCUMENTS SHALL BE PERFORMED BY THE CONTRACTOR UNLESS SPECIFICALLY NOTED OTHERWISE.
 - REFERENCE TO SPECIFIC SUBCONTRACTORS SUCH AS "MECHANICAL", "ELECTRICAL", ETC. ARE INTENDED TO SUGGEST POSSIBLE DIVISION OF RESPONSIBILITY. PRIME CONTRACTOR SHALL BE RESPONSIBLE FOR COORDINATION AND EXECUTION OF ALL WORK.
 - OBTAIN AND PAY FOR ALL REQUIRED PERMITS AND INSPECTIONS.
 - ALL EQUIPMENT, MATERIALS AND RELATED SYSTEM COMPONENTS SHALL BE NEW UNLESS NOTED OTHERWISE.
 - REPAIR AND REPLACE AT NO COST TO OWNER ALL EQUIPMENT AND MATERIALS DAMAGED DURING CONSTRUCTION.
 - STUDY THE PROJECT MANUAL & DRAWINGS OF ALL DISCIPLINES.
 - ELECTRICAL CONDUITS & BOXES SHALL BE CONCEALED IN WALLS OR ABOVE CEILING WHEREVER POSSIBLE.
 - ALL PENETRATIONS THROUGH WALLS & CEILING SHALL BE SEALED USING U.L. LISTED METHODS APPROPRIATE FOR INDICATED RATING.
 - NO PENETRATIONS ARE ALLOWED INTO STAR ENCLOSURES EXCEPT AS REQUIRED FOR SERVICES UTILIZED IN THE STAR.
 - ALL INSTALLATIONS ON NEW WALLS SHALL BE FULLY RECESSED. INSTALLATIONS ON EXISTING MASONRY WALLS SHALL BE RUN WITH SURFACE RACEWAY PAINTED TO MATCH WALL FINISH AND SURFACE BOXES. INSTALLATIONS ON EXISTING STUD WALLS SHALL CUT IN OLD-WORK STYLE BOXES AND FISH WIRING IN WALL CAVITY.
 - INVERTERS & SYSTEM COMPONENTS SHALL BE INSTALLED TO MEET NEC RAPID SHUTDOWN REQUIREMENTS.
 - SYSTEM AC DESIGN SIZE IS 248KW. ANY SUBMITTED SYSTEM MUST BE 248-249KW. BELOW 248KW OR ABOVE 249KW IS UNACCEPTABLE & WILL BE REJECTED.
 - PHOTOVOLTAIC PANEL STC MAXIMUM POWER MUST BE AT LEAST 369W. SUBMITTED PANELS MAY BE HIGHER THAN 369W AS LONG AS THE SYSTEM DESIGN WORKS & IS CODE COMPLIANT.

- PV SYSTEM GENERAL NOTES**
- ALL INVERTERS SHALL BE IEEE 1547 & UL 1741 COMPLIANT. IT SHALL BE INSPECTED BY LOCAL UTILITY BEFORE COMMISSIONING, TESTING AND OPERATION OF THE SYSTEM.
 - ALL OUTDOOR EQUIPMENT SHALL BE PROPERLY GROUNDED PER THE REQUIREMENTS OF NEC ARTICLE 250 & 690.
 - NEC ARTICLE 690.12 (A) PV SYSTEM DC CIRCUIT & INVERTER OUTPUT CONDUCTORS & EQUIPMENT SHALL BE PROTECTED AGAINST OVERCURRENT. CIRCUITS CONNECTED TO CURRENT LIMITED SUPPLIES & ALSO CONNECTED TO SOURCES HAVING HIGHER CURRENT AVAILABILITY SHALL BE PROTECTED AT THE HIGHER CURRENT SOURCE CONNECTION.
 - DUE TO THE FACT THAT PV MODULES ARE ENERGIZED WHENEVER THEY ARE EXPOSED TO LIGHT, PV CONTRACTOR SHALL DISABLE THE ARRAY DURING INSTALLATION AND SERVICE BY SHORT CIRCUITING, OPEN CIRCUITING, OR COVERING THE ARRAY WITH AN OPAQUE COVERING.
 - PROVIDE ALL MATERIALS NECESSARY FOR RAPID SHUTDOWN. TIGO RAPID SHUTDOWN PRODUCTS WILL NEED TO BE USED TO COMPLY WITH NEC ARTICLE 690.12. PV SYSTEM CIRCUITS INSTALLED ON OR IN BUILDINGS SHALL INCLUDE A RAPID SHUTDOWN FUNCTION TO REDUCE SHOCK HAZARD FOR EMERGENCY RESPONDERS IN ACCORDANCE WITH 690.12 (A) THROUGH (D).
 - NEC ARTICLE 690.12 (D) FOR PV SYSTEMS THAT SHUT DOWN THE ARRAY & CONDUCTORS LEAVING THE ARRAY, SOLAR PV SYSTEM IS EQUIPPED WITH RAPID SHUTDOWN. TURN RAPID SHUTDOWN SWITCH TO THE OFF POSITION TO SHUT DOWN PV SYSTEM & REDUCE SHOCK HAZARD IN ARRAY. THE TITLE SOLAR PV SYSTEM IS EQUIPPED WITH RAPID SHUTDOWN SHALL UTILIZE CAPITALIZED CHARACTERS WITH A MINIMUM HEIGHT OF 3/4" IN BLACK ON YELLOW BACKGROUND & THE REMAINING CHARACTERS SHALL BE CAPITALIZED WITH A MINIMUM HEIGHT OF 3/8" IN BLACK ON WHITE BACKGROUND.
 - NEC ARTICLE 690.13 (B) EACH PV SYSTEM DISCONNECTING MEANS SHALL PLAINLY INDICATE WHETHER IN THE OPEN (OFF) OR CLOSED (ON) POSITION & BE PERMANENTLY MARKED PHOTOVOLTAIC DISCONNECT OR EQUIVALENT. ADDITIONAL MARKINGS SHALL BE PERMITTED BASED UPON THE SPECIFIC SYSTEM CONFIGURATION FOR PV SYSTEM DISCONNECTING MEANS WHERE THE LINE & LOAD TERMINALS MAY BE ENERGIZED IN THE OPEN POSITION. THE DEVICE SHALL BE MARKED WITH THE FOLLOWING WORDS OR EQUIVALENT: "WARNING: ELECTRIC SHOCK HAZARD. TERMINALS ON THE LINE & LOAD SIDES MAY BE ENERGIZED IN THE OPEN POSITION." THE WARNING SIGN(S) OR LABEL(S) SHALL COMPLY WITH 10.2.1 (B).
 - NEC ARTICLE 690.13 (A) THE PV SYSTEM DISCONNECTING MEANS SHALL BE INSTALLED AT A READILY ACCESSIBLE LOCATION.
 - CONTRACTOR TO PROVIDE GROUND FAULT PROTECTION FOR ROOF MOUNTED PHOTOVOLTAIC ARRAYS IN ACCORDANCE WITH NEC ARTICLE 690.13 (B).
 - PHOTOVOLTAIC SOURCE CURRENTS MUST BE RATED AT BOTH 125% OF THE PARALLEL MODULE AND AT A CONTINUOUS LOAD OF ANOTHER 125% FOR A TOTAL OF 156% OF THE LOAD.
 - PROVIDE PERMANENT PLACARD OR DIRECTORY PROVIDING THE LOCATION OF THE SERVICE DISCONNECTING MEANS AND THE PHOTOVOLTAIC SYSTEM DISCONNECT MEANS IF THEY ARE NOT IN THE SAME LOCATION. A LABEL SHALL BE PERMANENTLY AFFIXED TO THE MAIN SERVICE DISCONNECT PANEL SERVING ALTERNATING CURRENT (AC) & DIRECT CURRENT (DC) PHOTOVOLTAIC SYSTEMS. THE LABEL SHALL BE RED WITH WHITE CAPITAL LETTERS AT LEAST 3/4" IN HEIGHT & IN A NONSERIF FONT. TO READ WARNING PHOTOVOLTAIC POWER SOURCE. THE MATERIALS USED FOR THE LABEL SHALL BE REFLECTIVE, WEATHER RESISTANT, & SUITABLE FOR THE ENVIRONMENT. 2018 IEEE CODE 112.2.11 MAIN SERVICE DISCONNECT MARKING.
 - INSTALLATION OF PV PANEL ARRAYS SHOULD RESIST BLDG AND POP-UP RESULTING FROM SEISMIC EVENTS AND SHOULD COMPLY WITH CBC SECTION 1613 AND ASCE STANDARD 7-05 CHAPTER 13.
 - PV SYSTEM INSTALLER WILL BE RESPONSIBLE FOR FURNISHING AND INSTALLING ALL RELATED EQUIPMENT, CABLES, ADDITIONAL CONDUITS, BOXES, WIRWAYS, AND ALL OTHER ACCESSORIES NECESSARY FOR A COMPLETE AND OPERATIONAL PHOTOVOLTAIC SYSTEM.
 - THE PV SYSTEM CONTRACTOR SHALL COORDINATE ALL WORK WITH THE ENGINEER, CONSTRUCTION MANAGER, AND OTHER CONTRACTORS TO INSURE THAT PV SYSTEM IS INSTALLED AS SPECIFIED IN THESE DOCUMENTS.
 - NEC ARTICLE 690.11 PHOTOVOLTAIC SYSTEMS OPERATING AT 60 VOLTS DC OR GREATER BETWEEN ANY TWO CONDUCTORS SHALL BE PROTECTED BY A LISTED PV ARC-FAULT CIRCUIT INTERRUPTER OR OTHER SYSTEM COMPONENTS LISTED TO PROVIDE EQUIVALENT PROTECTION. THE SYSTEM SHALL DETECT & INTERRUPT ARCING FAULTS RESULTING FROM A FAILURE IN THE INTENDED CONTINUITY OF A CONDUCTOR CONNECTION, MODULE OR OTHER SYSTEM COMPONENT IN THE PV SYSTEM DC CIRCUITS.
 - NEC ARTICLE 690.31 (B) PV SOURCE CIRCUITS & PV OUTPUT CIRCUITS SHALL NOT BE CONTAINED IN THE SAME RACEWAY, CABLE TRAY, CABLE, OUTLET BOX, JUNCTION BOX, OR SIMILAR FITTINGS AS CONDUCTORS, FEEDERS, BRANCH CIRCUITS OF OTHER NON-PV SYSTEMS, OR INVERTER OUTPUT CIRCUITS UNLESS THE CONDUCTORS OF THE DIFFERENT SYSTEMS ARE SEPARATED BY A PARTITION. PV SYSTEM CIRCUIT CONDUCTORS SHALL BE IDENTIFIED & GROUPED AS REQUIRED BY 690.31 (B)(1) THROUGH (D). THE MEANS OF IDENTIFICATION SHALL BE PERMITTED BY SEPARATE COLOR CODING, MARKING TAPE, TAGGING, OR OTHER APPROVED MEANS.
 - NEC ARTICLE 690.31 (C)(3) THE FOLLOWING WIRING METHODS & ENCLOSURES THAT CONTAIN PV SYSTEM DC CIRCUIT CONDUCTORS SHALL BE MARKED WITH THE WORDS "WARNING: PHOTOVOLTAIC POWER SOURCE" BY MEANS OF PERMANENTLY AFFIXED LABELS OR OTHER APPROVED PERMANENT MARKING: (1) EXPOSED RACEWAYS, CABLE TRAYS & OTHER WIRING METHODS; (2) COVERS OR ENCLOSURES OF PULL BOXES & JUNCTION BOXES; (3) CONDUIT BODIES IN WHICH ANY OF THE AVAILABLE CONDUIT OPENINGS ARE UNUSED.
 - NEC ARTICLE 690.31 (C)(4) THE LABELS OR MARKINGS SHALL BE VISIBLE AFTER INSTALLATION. THE LABELS SHALL BE REFLECTIVE, & ALL LETTERS SHALL BE CAPITALIZED & SHALL BE A MINIMUM HEIGHT OF 3/8" IN WHITE ON A RED BACKGROUND AND PV SYSTEM DC CIRCUIT LABELS SHALL APPEAR ON EVERY SECTION OF THE WIRING SYSTEM THAT IS SEPARATED BY ENCLOSURES, WALLS, PARTITIONS, CEILING, OR FLOOR. SPACING BETWEEN LABELS OR MARKINGS, OR BETWEEN A LABEL & A MARKING, SHALL NOT BE MORE THAN 10'. LABELS REQUIRED BY THIS SECTION SHALL BE SUITABLE FOR THE ENVIRONMENT WHERE THEY ARE INSTALLED.
 - ALL CABLES, CONDUCTORS, RACEWAY & FITTINGS INSTALLED OUTDOORS & EXPOSED TO DIRECT SUNLIGHT & WET CONDITIONS MUST BE SUITABLE FOR THESE CONDITIONS. CONDUCTORS INSTALLED INSIDE RACEWAYS INSTALLED IN WET LOCATIONS ARE REQUIRED TO BE IDENTIFIED OR LISTED AS SUITABLE FOR WET LOCATIONS.
 - EVERSOURCE REQUIRES A UTILITY ACCESSIBLE DISCONNECT SWITCH WHICH IS ACCESSIBLE TO COMPANY PERSONNEL AT ALL HOURS OF ALL DAYS & CAN BE OPENED FOR ISOLATION IF REQUIRED. THE DEVICE SHALL HAVE PROPER PLACARDS FOLLOWING NEC SIGNAGE. SIGNAGE MUST BE OF A PERMANENT NATURE. USE UV STABLE MATERIALS & ADHESIVE. SUITABLE FOR OUTDOOR ENVIRONMENTAL LIFE CYCLE. THE DISCONNECT SHALL BE GANG OPERATED, HAVE A VISIBLE BREAK WHEN OPEN, BE SEATED TO INTERRUPT MAXIMUM DISTRIBUTED ENERGY RESOURCES FACILITY OUTPUT & BE CAPABLE OF BEING LOCKED OPEN.

PV MODULE RATINGS @ STC
OPEN-CIRCUIT VOLTAGE (Voc): 49.1
OPERATING VOLTAGE (Vmp): 40.8
OPERATING CURRENT (Imp): 9.44
SHORT-CIRCUIT CURRENT (Isc): 9.92
MAXIMUM POWER (W): 385
Voc TEMP COEFF (mV OR %/°C) = -0.048
INVERTER RATINGS
MAX DC VOLT RATING (V): 1000
MAX POWER @ 40°C (W): 60000
NORMAL AC VOLTAGE (V): 480
MAX AC CURRENT (A): 79.4
MAX DC/DC RATING (A): 100
INVERTER RATINGS
MAX DC VOLT RATING (V): 1000
MAX POWER @ 40°C (W): 50000
NORMAL AC VOLTAGE (V): 480
MAX AC CURRENT (A): 60.2
MAX DC/DC RATING (A): 80
TOTAL SYSTEM DESIGN
TOTAL QUANTITY OF PANELS: 760
TOTAL SYSTEM KW (DC): 292.60
TOTAL SYSTEM KW (AC): 248
SYSTEM RATIO (DC/AC): 1.18

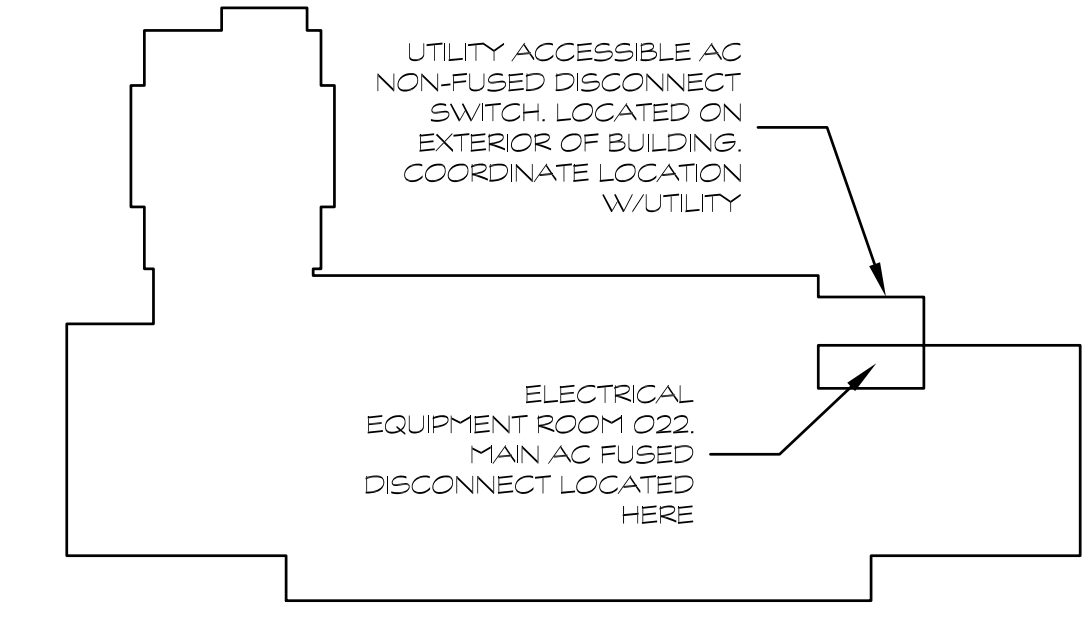
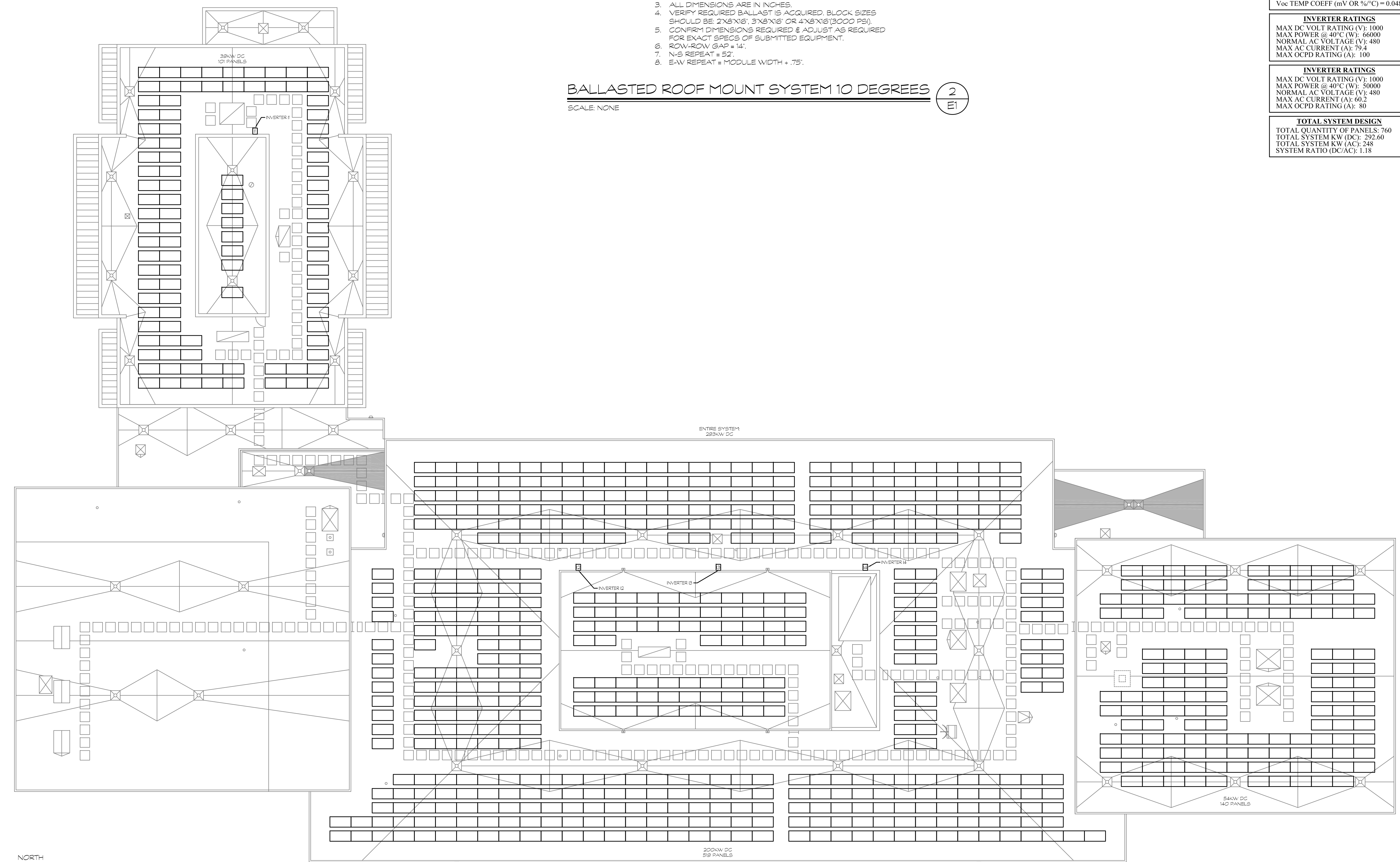

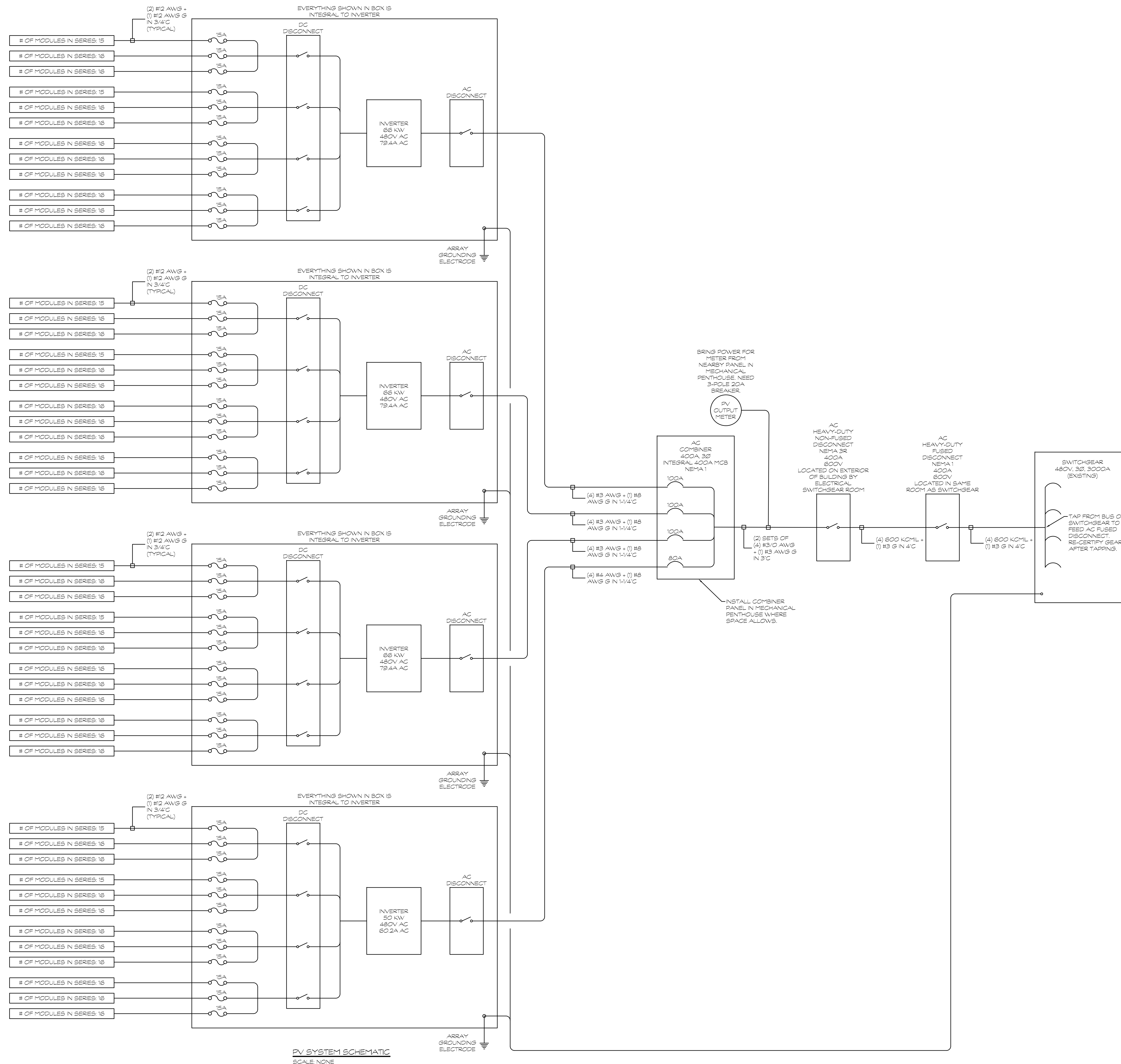

Revision	Description	Date	Revised By