

**Kevin M. DelGobbo Memorial Field Irrigation
NAUGATUCK, CONNECTICUT**

Contract No. 20-27

CONTRACT DOCUMENTS

**PREPARED BY THE
BOROUGH OF NAUGATUCK
CONNECTICUT**

February 2020

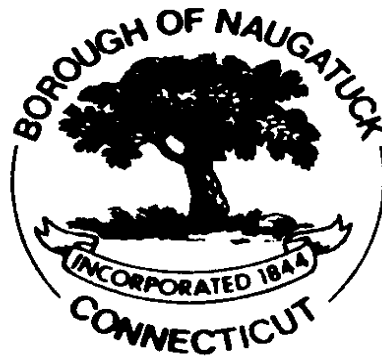

BOROUGH OF NAUGATUCK
INVITATION TO BID

Borough of Naugatuck

Sealed bids will be received and opened at the Borough of Naugatuck, Town Hall, Purchasing Office (located in the basement), 229 Church Street, Naugatuck, CT 06770, on **Monday February 24, 2020 at 11:00 a.m.**, at which time and place all bids will be publicly opened and read aloud for supplying The Borough of Naugatuck with the following:

Contract No. 20-27

Kevin M. DelGobbo Memorial Field Irrigation

The Contract Documents may be examined at the Office of the Purchasing Agent, Town Hall, 229 Church Street, Naugatuck, CT 06770.

Contract Documents can be obtained at no cost from the Borough of Naugatuck web site <http://www.naugatuck-ct.gov>. All firms obtaining Contract Documents and wishing to be sent any addendums shall submit contact information by e-mail to jscully@naugatuck-ct.gov. All bidders must check the Naugatuck web site no more than three days prior to the bid opening to check for addendums.

The Borough of Naugatuck reserves the right to waive any informalities or to reject any or all bids.

No Bidder may withdraw his bid within (90) days after the actual date of the opening thereof.

“An Affirmative Action/Equal Opportunity Employer. Minority/Women's Business Enterprises are encouraged to apply. This contract is subject to state set-aside and contract compliance requirements.”

SPECIFICATIONS

STANDARD SPECIFICATIONS

The material and construction methods for the work specified in this contract shall conform with the applicable provisions of the State of Connecticut, Department of Transportation specifications entitled “*STANDARD SPECIFICATIONS FOR ROADS, BRIDGES AND INCIDENTAL CONSTRUCTION*”, Form 817, 2016, as revised by the Supplemental Specifications including all Supplements (otherwise referred to collectively as “ConnDOT form 817”) unless modified by the Special Provisions contained herein. “ConnDOT form 817” is hereby made part of this contract. Form 817 may be Down loaded from the Connecticut Department of Transportation Web Site.

All references to Commissioner, Department, Engineer, and State anywhere within the Form 817 shall be interpreted to mean the Borough of Naugatuck or a duly authorized agent of the Borough. Any questions or ambiguity regarding any definitions shall be brought to the immediate attention of the Borough.

INDEX TO CONTRACT DOCUMENTS

SECTION

A	Information for Bidders
B	Proposal
C	References/Qualifications
D	Bid Bond / Surety Guarantee Form
E	Contract and Agreement / Certificate as to Corporate Principal
F	Performance Bond
G	Payment Bond
H	Specifications
I	Contract Drawings
J	Field Ledge Locations

SECTION A

INFORMATION FOR BIDDERS

Borough of Naugatuck

Contract No. 20-27

Kevin M. DelGobbo Memorial Field Irrigation

1. Proposals Received

Sealed Bids for construction of the Kevin M. Delgobbo Memorial Field Irrigation System will be received by the Purchasing Office, Borough of Naugatuck, 229 Church Street, Naugatuck, CT 06770 until **Monday February 24, 2020, at 11:00 A.M.** local time. Immediately following the bids will be publicly opened and read aloud.

2. Location and Description of Work

These specifications will provide a basis for the furnishing of all materials, equipment, labor, transportation, testing and other goods and services necessary to install complete Irrigation System at Kevin M, DelGobbo Memorial Field at Osborn Road in Naugatuck Connecticut.

3. None

4. Specifications

Copies of the Specifications may be seen and obtained at the Purchasing Office, Borough of Naugatuck, 229 Church Street, Naugatuck, CT 06770. The construction contract for the **Contract No. 20-27 Kevin M. DelGobbo Memorial Field Irrigation**, will be entered into by the successful bidder and the Borough of Naugatuck. The State of Connecticut Department of Transportation Standard Specifications for Roads, Bridges and Incidental Construction, Form 817 along with supplemental specifications contained herein will detail the general requirements for materials, methods of installation, measurement and basis of payment to be required in this project. Any references to the State of Connecticut, the Department, the commissioner, Engineer, or other terms indicating the State of Connecticut and her agents as party to the contract shall for this project mean the Borough of Naugatuck and her designated agents or employees.

Where insurance is required to be carried in the name of the State of Connecticut and the State of Connecticut is to be held harmless, this shall be done in the name of the Borough of Naugatuck and the Borough of Naugatuck shall be held harmless.

All requirements for material testing, certificates of the compliance, or material certifications shall be done as if this were a contract being entered into with the State of Connecticut.

It is the intent of this contract to maintain all standard requirements of Form 817 without attempting to redefine every term within the 817 to the "Borough of Naugatuck".

The bidder shall, therefore, be aware that the Borough of Naugatuck and her agents shall

inspect and administrate this contract, make contract interpretations, determine the acceptability of the work and approve requests for payments. The Contractor shall be responsible for the requirements stated in Form 817 and in the construction drawings.

5. Addenda and Interpretations

No interpretations of the meaning of the Specifications, or other pre-bid documents will be made to any Bidder orally.

Every request for such interpretation shall be in writing, addressed to Mr. James Stewart, P.E., Borough of Naugatuck, Department of Public Works Office, 246 Rubber Ave. Naugatuck, CT 06770. To be given consideration, such requests must be received at least six (6) days prior to the date fixed for the opening of bids. Any and all such interpretations and any supplemental instructions will be in the form of written addenda to the specifications, which, if issued, will be mailed by certified mail with return receipt requested to all prospective Bidders, at the respective address furnished for such purposes, not later than four (4) days prior to the date fixed for the opening of bids. Failure of any Bidder to receive any such addendum or interpretations shall not relieve such Bidder from any obligation under his bid as submitted. All addenda so issued shall become part of the Contract Documents.

6. Familiarity of the Work

Each Bidder shall fully inform himself prior to bidding as to existing conditions and limitations under which the work is to be performed, and shall include in his bid a sum to cover the cost of items necessary to perform the work as set forth in the Contract Documents. No allowance will be made to a Bidder because of lack of such examination or knowledge. The submission of a bid will be considered as conclusive evidence that the Bidder has made such examination.

The Owner assumes no responsibility whatsoever with respect to ascertaining for the Contractor such facts concerning physical characteristics at the site of the project.

The Contractor agrees that he shall make no claim for and has no right to additional payment or extension of time for completion of the work, or any other concessions, because of any interpretations or misunderstanding on his part of this Contract, or because of any failure on his part to fully acquaint himself with all conditions relating to the work.

Attached to the bid package is a draft list of roads that are proposed to be paved additional roads and locations may be added or removed as needed.

7. None

8. Estimate of Work

For bidding purposes, the work has been subdivided into unit price items. The quantities shown below are to be considered as approximate only. The Inspector does not expressly or by implication agree that the actual quantity(ies) will correspond therewith, but reserves the right to increase or decrease the amount of any Item or portion of the work as may be deemed necessary.

9. Qualification of Bidders

A Bidder shall be a contractor who is experienced in the construction of the projects of this type. The Proposal shall contain adequate proof of the qualifications of the Bidder to perform, in a satisfactory manner and within the time specified, all the work covered by

the Plans and Specifications. This proof shall be fully recorded on the pages titled "References", which shall become part of the Proposal.

10. Disqualification of Bidders

More than one proposal from an individual, firm, partnership, corporation, or an association under the same, or different, names will not be considered. Reasonable grounds for believing that any Bidder is interested in more than one proposal for the work contemplated will cause the rejection of all proposals in which such Bidder is interested. Any or all proposals in which such Bidder is interested will be rejected if there is reason for believing that collusion exists among the Bidders; and all participants in such collusion will not be considered in future proposals for the same work. Proposals in which the prices are obviously unbalanced may be rejected. No Contract will be awarded except to competent Bidders capable of performing the class or work contemplated.

11. Preparation of Proposals

The Proposal must be made upon the forms contained herein. The blank spaces in the Proposals must be filled in correctly where indicated. The Bidder must state, both in words and in numerals, written or printed in ink, the prices for which he proposes to do each Item of the work contemplated. In case of discrepancy between the words and the numerals, the words shall govern. Ditto marks are not considered writing, or printing, and shall not be used. The Bidder shall sign his Proposal correctly. If an individual makes the Proposal, his name and post office address must be shown. If made by a firm, partnership, or corporation, the Proposal must be signed by an official of the firm, partnership, or corporation authorized to sign contracts, and must show the post office address of the firm, partnership, or corporation.

Each bid must be submitted in a sealed envelope bearing on the outside the name of the Bidder, this address, and name of the project for which the bid is submitted. If forwarded by mail, the sealed envelope containing the bid must be enclosed in another envelope addressed to: Purchasing Office, Borough of Naugatuck, City Hall, 229 Church Street, Naugatuck, CT 06770.

12. Irregular Proposals

The Borough of Naugatuck reserves the right to reject any proposals if they show any omission, alteration of form, additions not called for, conditional bids, or irregularities of any kind.

13. Proposal Guarantee

No proposal will be considered unless accompanied by a certified check in U.S. dollars, or bid bond using an insurance company licensed to do business in the State of Connecticut in an amount of \$5,000.00 payable to the order of the Borough of Naugatuck, said check or bid bond to be returned to the Bidder unless forfeited as hereinafter stipulated. Such checks or bid bonds will be returned to all bidders within five (5) days after the execution of the Contract and the furnishing of the required security by the successful Bidder.

14. Withdrawal of Proposals

If a Bidder wishes to withdraw his Proposal, he may do so before the time fixed for the opening of bids by communicating his purpose to the office of the Mayor. Upon such notice, the Proposal will be handed to him unopened.

15. Execution of Contract

The party to whom the Contract is awarded, or his authorized representative, will be required to attend at the office of the Mayor, Borough of Naugatuck, with the sureties offered by him, or them, and a current certificate of Corporate good standing issued by the Office of the Secretary of State in which the corporation is incorporated, and execute the Contract within five (5) days from the date of the award. If the party entering into this contract is a corporation, a Corporate Resolution duly executed by the president and Secretary of the Corporation authorizing the Corporation to enter into this Contract shall be provided. In case of his failure or neglect to do so, the Owner may, at its opinion, determine that the Bidder has abandoned the Contract and thereupon the Proposal and acceptance shall be null and void, and bid security accompanying the Proposal shall be forfeited as liquidated damages to the Owner. If the party entering into this contract is a partnership, a partnership resolution duly executed by a majority of the general partners authorizing the partnership to enter into this contract shall be provided.

16. Bonds

The successful Bidder, at the time of the execution of the Contract, shall furnish a Performance Bond in an amount of \$200,000.00 as security for the faithful performance of this Contract and also a Payment bond in an amount of \$200,000.00 of the Contract prices as security for the payment of all persons performing labor on the project under this Contract and furnishing materials in connection with this Contract. All Bonds shall be in the forms prescribed by Law or Regulation and be acceptable to the Owner. Surety companies executing Bonds must appear on the Treasury Department's most current list (Circular 570 as amended) and be authorized to transact business in the State of Connecticut. Bidder shall provide evidence that Surety Company is licensed to conduct business in the State of Connecticut. All sureties shall be in full force throughout the guarantee period and until the retainage is released.

17. Ledge- Rock Excavation.

The contractor shall include the cost of rock excavation in their base bid. The contractor shall complete all necessary exploratory work prior to bidding to ensure that they have determine the amount of rock that will be encountered. The Borough has provided a sketch of the approximate ledge elevations. The contractor shall utilize this drawing as reference only; The Borough shall not be responsible for the accuracy of this drawing.

18. Responsibility of the Contractor

Attention is hereby particularly directed to the provisions of the Contract and Specifications whereby the Contractor shall be responsible for any loss or damage that may happen in the work, or any part thereof, during its progress and also whereby the Contractor shall make good any defects for faults that may occur within one (1) year after date of final estimate. He shall indemnify and save harmless the Owner and Engineer from any damages or costs to which they may be put by reason of injury to the person or property of another resulting from negligence or carelessness in the performance of the work under this Contract.

19. Insurance

Before execution of the Contract, the Bidder will be required to file with the Borough of Naugatuck a certificate of insurance. The certificate, executed by an insurance company satisfactory to the Borough of Naugatuck shall name the Borough of Naugatuck and the State as additional insured parties on the form furnished with these specifications. The "Certificate of Insurance" shall state that at a minimum, with respect to the contract, the bidder carries insurance in accordance with the requirements and stipulations listed

below.

Unless requested otherwise by the Borough of Naugatuck, the Bidder and its insurer shall not assert the defense of governmental immunity in the adjustment of claims or in the defense of any claim or suit brought against the Borough of Naugatuck and the State. The Bidder shall assume and pay all cost and billing for premiums and audit charges earned and payable under the required insurance.

A. Workmen's Compensation Insurance: With respect to all operations the Bidder performs and all those performed for it by subcontractors, the Bidder shall carry workmen's compensation insurance in accordance with the requirements and the laws of the State.

B. Contractor's Public Liability and Property Damage Insurance: With respect to the Project operations the Bidder performs and also those performed for it by subcontractors, the Bidder shall carry regular Contractor's Public Liability Insurance. The insurance shall provide coverage for each accident or occurrence in the amount of \$2,000,000 for all damages resulting from (1) bodily injury to, or death of, persons and/or (2) injury to or destruction of property. Subject to that limit per accident or occurrence, the policy shall provide a total or aggregate coverage of \$2,000,000 for all damages during the policy period.

C. Automobile Liability Insurance: The operation of all motor vehicles, including those hired or borrowed, used in connection with the project, shall be covered by Automobile Liability Insurance. The insurance shall provide coverage for each accident or occurrence in the amount of \$2,000,000 for all damages resulting from (1) bodily injury to, or death of, persons and/or (2) injury to or destruction of property. If an insurance policy shows an aggregate limit as part of the automobile liability coverage, the aggregate limit must be at least \$2,000,000.

D. With respect to the project operations the Bidder performs and also those performed for it by subcontractors, the Bidder shall carry for and on behalf of the Borough of Naugatuck, and State, insurance which shall provide coverage for each accident or occurrence in the amount of \$2,000,000 for all damages resulting from (1) bodily injury to or death of person and/or (2) injury to or destruction of property. Subject to that limit per accident or occurrence, the policy shall provide a total or aggregate coverage of \$2,000,000 for all damages during the policy period.

E. Railroad's Protective Liability Insurance: When the contract involves work on, over or under the right of way of any railroad company, the Bidder shall, with respect to the project operations it performs and also those performed for it by subcontractors, carry Railroad Protective Liability Insurance for and on behalf of the railroad company. The insurance shall provide coverage for each accident and occurrence in the amount of \$2,000,000 for all damages resulting from (1) bodily injury to or death of persons and/or (2) injury to or destruction of property. Subject to that limit per accident or occurrence, the policy shall provide a total or aggregate coverage of \$6,000,000 for all damages during the policy period.

F. Blasting: When explosives are to be used in the prosecution of the work, the insurance required under paragraphs b, d and e above shall also contain provisions for protection, in the amounts state, against damage claims due to such use of explosives.

G. Termination or change of Insurance: Each insurance policy shall be endorsed to provide that the insurance company shall notify the Borough of Naugatuck by certified mail at least thirty (30) days in advance of termination, or any change in the policy. No such change shall be made without prior written approval of the appropriate Official.

H. Claims: Each insurance policy shall state that the insurance company shall agree to investigate and defend the Borough of Naugatuck and State against all damages, even if groundless.

I. Compensation: There shall be no direct compensation allowed the Bidder on account of any premium or other charge necessary to take out and keep in effect all insurance or bonds, but the cost thereof shall be considered included in the general cost of the work.

20. Care and Protection of Property

The Contractor shall take particular care to avoid damages to all private property and to private improvements within the Boroughs' right of way. He shall make good any damages to the satisfaction of the Inspector. There shall be no additional compensation for the repair or restoration of private property, or private improvements, within the Boroughs' right of way.

21. Sales Tax

Certain materials and supplies incorporated in the work of this project are exempt from Connecticut Sales Tax. The Bidder shall familiarize himself with current regulations of the State Tax Department. The tax on materials or supplies exempted by such regulations shall not be included as part of the bid. The Owner will furnish the successful Bidder a sales tax exemption number.

22. Compliance with Federal and State Regulations

The Contractor shall be responsible for full compliance with any Federal and/or State laws, regulations and standards, as applicable to any project fully or partially funded by State and/or Federal funding agency. This project is funded, in part, by the State and Federal government.

23. Permits

All licenses and permits for complying with any applicable Federal, State, and Municipal laws, codes and regulations in connection with the prosecution of the work shall be obtained by the Contractor, at no additional cost to the Owner.

24. Sedimentation and Erosion Control Plan

The Contractor shall prepare a sedimentation and erosion control plan for the work if applicable.

25. Contractor's Right to Terminate Work

If the work should be stopped under an order of any court or other public authority, for a consecutive period of not less than thirty (30) days, through no act or fault of the Contractor or of anyone employed by him, then the Contractor may terminate this Contract and recover from the Owner payment for all work executed.

26. None

27. Power of Attorney

Attorneys-in-fact who sign contract bonds must file, with each bond, a certified and

effectively dated copy of their power of attorney.

28. Right to Reject

The Owner reserves the right to reject any or all proposals or to accept any bid, should it deem it to be in the best interest of the Owner

29. Prevailing Wage Rates:

A. Prevailing wage rates do not apply in this contract

Contract No. 20-27

Kevin M. DelGobbo Memorial Field Irrigation

SECTION B

PROPOSAL

The undersigned, as Bidder, declares that no person or persons, other than those named herein, are interested in this Proposal; that this Proposal is made without collusion with any person, firm or corporation; that he has carefully examined the location of the proposed work, the proposed Form of Contract, and the Contract Drawings therein referred to; that no person or persons acting in any official capacity for the Owner is directly or indirectly interested therein or in any portion of the profit thereof; and that he proposes and agrees, if this Proposal is accepted, to execute the Form of Contract with the Owner; to provide all necessary equipment, tools, and other means of construction, and to do all work and furnish all materials specified in the Contract, in the manner and time therein prescribed, and according to the requirements of the Borough of Naugatuck Inspector as therein set forth, and that he will take in full payment therefore, the following unit prices and lump sums, to wit:

The Bidder acknowledges receipt of the following addenda:

Addendum No. _____ Dated: _____

Addendum No. _____ Dated: _____

The undersigned agrees that he shall execute the Contract within the ten (10) days after the date of award, and shall commence work within the ten (10) days after date of the Notice to Proceed and shall progress therewith to its entire completion within the time stipulated in the Contract.

The Bidder agrees that this bid shall be good and may not be withdrawn for a period of ninety (90) days after the scheduled closing time for receiving bids.

If this Proposal shall be accepted by the Owner and the undersigned shall fail to contract as aforesaid, and to give bonds as required, as determined by the canvass of bids, and with surety or sureties satisfactory to the Owner within ten (10) days from the date of the award, then the Owner may, at its option, determine that the Bidder has abandoned the Contract: thereupon, the Proposal and acceptance shall be null and void, and the bid security, accompanying this Proposal, shall become the property of the said Owner as liquidated damages for the delay and additional expense to the Owner caused thereby if said Proposal shall be rejected, or if said Proposal shall be accepted and the Bidder shall execute and deliver a contract in the Form of Contract attached hereto (properly completed in accordance with said Proposal) and shall furnish a Bond for his faithful performance of said Contract, and for the payment of all persons performing labor or furnishing materials in connection therewith, and shall in all other respects perform the agreement created by the acceptance of said Proposal, the accompanying bid security shall be returned to the undersigned making bid.

The undersigned is aware that the Borough of Naugatuck may reject any and all bids in whole or in part; that the Borough may waive technical defects, irregularities and omissions; that the award will be based on the combination of items that will best serve the interest of the Borough; that the bid price does not include any taxes for which the Borough is not liable; and that acceptance of the bid will establish no exclusive contract by which the Borough of Naugatuck will be required to purchase from the undersigned.

Contract No. 20-27
Kevin M. DelGobbo Memorial Field Irrigation

PROPOSAL continued

The undersigned claims without reservation that his/her bid is made without collusion with any other person, individual or corporation.

Items not specifically identified for payment in the Bid Form shall be assumed to be included in the work effort of other bid items and shall not be paid or requested for payment separately.

Item 1. Irrigation System at Kevin M, DelGobbo Memorial Field.

Including all materials, equipment, labor, transportation, rock removal, testing and other goods and services necessary to install a complete and fully functioning Irrigation system as specified.
(Lump Sum)

\$ _____

Alternate Item #2. Alternate Booster Pump As specified in Part 2 Item 2.2.E.4. of the Irrigation specification.

\$ _____

Company Name: _____

Address: _____

Town: _____

Telephone: _____

Email: _____

Agent Name: _____

Agent Signature: _____

SECTION C

REFERENCES/QUALIFICATIONS

The Bidder is required to fill out the following form to enable the Owner to make inquiries and judge as to the Bidder's experience, skill, available financial resources, credit, and business standing.

1. Number of years the bidder has been in business as a General Contractor: _____

2. Has the Bidder ever failed complete work awarded; and if so, state where and why:

3. Does the Bidder plan to sublet any part of this work; and if so, give details:

4. List equipment Bidder owns that is available for this project:

5. List equipment the Bidder plans to rent or purchase for this project:

Major Material Supplier: _____

Bidder

SECTION D

BID BOND /SURETY GUARANTY

BID BOND

KNOW ALL MEN BY THESE PRESENTS, that we the undersigned:

as Principal, and _____ as Surety are held and firmly bound unto Borough of Naugatuck hereinafter called the "Owner", in the penal sum of _____ Dollars, (\$ _____) lawful money of the United States, for the payment of which sum well and truly to be made, we bind ourselves, our heirs, executors, administrators, successors, and assigns, jointly and severally, firmly by these presents.

THE CONDITIONS OF THIS OBLIGATION IS SUCH, that whereas the Principal has submitted the accompanying BID, dated _____, 20____, for _____

NOW THEREFORE, if the Principal shall not withdraw said Bid within the time period specified therein after the opening of the same, or within any extended time period agreed to by the Principal, Surety and Owner, or, if no period be specified, within ninety (90) days after the said opening, and shall within the period specified thereof, or if no period be specified, within twenty (20) days after the prescribed forms are presented to him for signature, enter into a written Contract with the Owner in accordance with the Bid as accepted, and give bond with good and sufficient surety or sureties, as may be required, for the faithful performance and proper fulfillment of such Contract; then the above obligation shall be null and void and of no effect, otherwise to remain in full force or virtue.

Failure to comply with the aforementioned condition shall result in the forfeiture of this BID BOND as liquidated damages.

IN WITNESS WHEREOF, the above-bounded parties have executed this Instrument under their several seals this _____ day of _____, 20____, the name and corporate seal of each corporate party being hereto affixed and these presents signed by its undersigned representative, pursuant to authority of its governing body.

No extension of time or other modification of the BID BOND shall be valid unless agreed to in writing by the parties to this Bond.

BID BOND
(Page 2 of 2)

In presence of:

(Individual Principal)

(Business Address)

(Individual Principal)

(Business Address)

Attest:

(Corporate Principal)

(Business Address)

By:

Affix
Corporate
Seal

Attest:

(Corporate Surety)

(Business Address)

By:

Affix
Corporate
Seal

Countersigned

By: _____

* Attorney-in Fact, State of _____

* Power-of Attorney for person signing for Surety Company must be attached to Bond.

SURETY GUARANTY FORM

(To accompany Proposal)

KNOW ALL MEN BY THESE PRESENTS, that for and in consideration of the sum of \$1.00, lawful money of the United States, the receipt whereof is hereby acknowledged, paid the undersigned corporation, and for other valuable consideration, the _____
_____ a

(Name of Surety Company)

corporation organized and existing under the laws of the State of _____ and licensed to do business in the State of Connecticut, certifies and agrees, that if the Contract for the Road Paving Program is awarded to _____, the undersigned corporation will execute the

(Name of Bidder)

bond or bonds as required by the Contract Documents and will become Surety in the full amount of the Contract Price for the faithful performance of the Contract and for payment of all persons supplying labor or furnishing materials in connection therewith.

(Surety)

(To be accompanied by the usual proof of authority of officers of Surety Company to execute the same.)

SECTION E

CONTRACT AGREEMENT AND CERTIFICATE AS TO CORPORATE PRINCIPAL

CONTRACT AND AGREEMENT

THIS AGREEMENT, made this _____ day of _____ in the year 20____,
Between the Borough of Naugatuck, with its principal office and place of business at 229
Church Street, Connecticut 06770, acting herein through it's Mayor and
_____, a _____, with an office and
place of business at _____, hereinafter called the contractor.

WITNESSETH: That the parties to this agreement in consideration of the undertakings,
promises, and agreements on the part of the other herein contained, hereby undertake, promise,
and agree as follows:

I Definitions

The word "Owner" as used herein shall mean the Borough of Naugatuck, acting through
its properly authorized representatives.

The words "as directed", "as required", "as permitted", "as allowed", or phrases of like
effect or import, used herein shall mean that the direction, requirement, permission, or allowance
of the Borough of Naugatuck Inspector is intended and similarly the words "approved",
"reasonable", "suitable", "proper", "satisfactory", or words of like effect or import, unless
otherwise particular specified herein, shall mean approved, reasonable, suitable, proper, or
satisfactory in the judgement of the Borough of Naugatuck Inspector.

The word "Contractor" shall mean _____ or it's duly authorized agents.

II Contract Includes

The indices, headings and subheadings are for convenience only and do not form a part of
the Contract Documents.

The Contractor shall, at his own sole cost and expense, furnish all labor, materials, and
other services necessary for the completion of this Contract and shall complete and finish the
same in the most thorough, workmanlike, and substantial manner, in every respect, to the
satisfaction and approval of the Borough of Naugatuck Inspector, in the manner and within the
time hereinafter limited, and in strict accordance with the Advertisement, Information for
Bidders, Proposal, General Requirements, Detailed Specifications, and Addenda hereto attached,
and the Contract Drawings herein referred to, (collectively the "contract documents"), which
contract documents are hereby made a part of this Contract as fully as if the same were repeated
at length herein.

Addendum No. ____ Dated: _____ Addendum No. ____ Dated: _____
Addendum No. ____ Dated: _____ Addendum No. ____ Dated: _____
Addendum No. ____ Dated: _____ Addendum No. ____ Dated: _____

III Specifications and Contract Drawings Supplementary

The said Specifications and Contract Drawings are intended to supplement each other, and together constitute one complete set of Specifications and Contract Drawings, so that any work exhibited in the one and not in the other shall be executed just as if it had been set forth in both, in order that the work shall be completed in every respect according to the complete design or designs as decided and determined by the Borough of Naugatuck Inspector. Should anything be omitted from the Specifications and Contract Drawings, the Contractor shall promptly notify the Borough of Naugatuck Inspector. From time to time during the progress of the work, the Borough of Naugatuck Inspector will furnish such supplementary or working drawings as are necessary to show changes or define the work in more detail, and these also shall be considered as Contract Drawings. When discrepancies exist between the Contract Drawings and Specifications, the Specifications shall govern.

IV Modifications

The Contractor, in entering into this Contract, understands that the Owner reserves the right to modify, to the extent herein provided, the arrangement, character, grade, or size of the work or appurtenances whenever, in the Owner's opinion, it shall be deemed necessary or advisable to do so. Minor changes in the work, not involving extra cost and consistent with the purposes of the work, may be made by verbal order, but no modifications involving extra work or material changes shall be made unless ordered in writing by the Borough of Naugatuck Inspector; and if the modification requires additional cost, a purchase order must be issued prior to work commencing. The Contractor shall and will accept such modifications when ordered in writing by the Owner through the Borough of Naugatuck Inspector, and the same shall not vitiate or void this Contract.

Any such modifications so made shall not, however, subject the Contractor to increased expense without equitable compensation, which shall be determined by the Borough of Naugatuck Inspector. If such modifications result in a decrease in the cost of work involved, and equitable deduction from the Contract price, to be determined by the Borough of Naugatuck Inspector, shall be made. The Borough of Naugatuck Inspector's determination of such additional compensation, or of any such deduction, shall be based upon the unit prices in the Contractor's bid, unless the modification involves work not included in such bids and then in the event, the modification shall be as set forth in Section XXVIII prior to the commencement of additional work. In no event shall any modification in the work shown on the Plans and Specifications be made unless the nature and extent thereof has first been certified by the Borough of Naugatuck Inspector in writing and sent to the Contractor.

V Correction of Errors and Omissions

The Plans and Specifications forming part of this Contract are intended to be explanatory of each other, but should any discrepancy appear, or misunderstanding arise, as to the import of anything contained in either, the explanation and decision of the Borough of Naugatuck Inspector shall be final and binding on the Contractor; and all directions and explanations required, to complete and make effective any of the provisions of the Contract and Specifications, shall be given by the Borough of Naugatuck Inspector. Corrections of errors and omissions in the Drawings or Specifications may be made by the Borough of Naugatuck Inspector when such corrections are necessary for the proper fulfillment of the Contract Documents as construed by the Borough of Naugatuck Inspector. The effect of such corrections shall date from the time that the Borough of Naugatuck Inspector gives due notice thereof to the Contractor.

VI Borough of Naugatuck Inspector's Decision

All work under this Contract shall be done to the satisfaction of the Borough of Naugatuck Inspector, who shall determine the amount, quality, acceptability, and fitness of the several items of work and materials which are to be paid for hereunder. He also shall decide all questions which may arise as to the fulfillment of the terms of the Contract, Plans and Specifications. The determination of the Borough of Naugatuck Inspector in all such matters shall be final and binding upon the parties thereto.

VII Inspection of Work

It is agreed that the Owner may, at its pleasure, appoint and employ, at its own expense, such persons as may be necessary, who are to act as Borough of Naugatuck Inspectors, inspections, or agents, for the purpose of determining, in the Borough's interest, that the materials furnished and the work done, as the work progresses, conforms to the requirements of the Contract Documents. Such persons shall have unrestricted access to all parts of the work and to other places at and where the preparation of the materials and other parts of the work to be done under this Contract are carried on and conducted. They shall be given, by the Contractor, all facilities and assistance required to carry out their work of inspection.

It is not the function of the Borough of Naugatuck Inspector to supervise or direct the manner in which the work to be done under this Contract is carried on or conducted. The Borough of Naugatuck Inspector is not responsible for construction means, methods, techniques, sequences, or procedures, or for safety precautions and programs in connection with the work, and he will not be responsible for the Contractor's failure to carry out the work in accordance with the Contract Documents.

The Borough of Naugatuck Inspector shall have authority to reject and shall reject any work or material, or any part thereof, which does not, in his opinion, conform to the Contract Drawings, working drawings, Specifications, and Contract, and it shall be permissible for him to do so at any time during the progress of the work.

No work shall be done except in the presence of the Borough of Naugatuck Inspector or his assistants. No material of any kind shall be used upon the work until it has been inspected and accepted by the Borough of Naugatuck Inspector. Any materials or workmanship found at any time to be defective, or not of the quality or character required by the Contract Drawings and Specifications, shall be remedied at once regardless of previous inspection.

Such inspection shall not relieve the Contractor from any obligation to perform said work strictly in accordance with the Contract Drawings and Specifications, and work not so constructed shall be removed and made good by the Contractor at this own expense and free of all expense to the Owner, whenever so ordered by the Owner, without reference to any previous oversight or error in inspection.

VIII Address of Contractor

The address in the Proposal, upon which this Contract is based, shall be the place. The delivering at the above-named place of any such notice, letter, or other communication where notices, letters or other communications to the Contractor may be mailed or delivered, from the Borough to the Contractor, the date of said service shall be the date of such delivery. Nothing herein contained shall be deemed to preclude or render inoperative the service of any notice, letter, or other communication upon the Contractor personally.

IX Obligation of the Contractor

The Contractor shall, at his own expense, provide any and all manner of supervisor, insurance, taxes, labor, materials, apparatus, scaffolding, appliances, tools, machinery, power, transportation, and whatever else may be required of every description necessary to do and complete the work and shall be solely answerable for the same and for the safe, proper, and lawful construction, maintenance, and use thereof. The Contractor shall cover and protect the work from damage and shall make good all injury to the same occurring before completion of this Contract. The Contractor shall employ only competent workmen and shall provide experienced superintendents and foremen on each part of the work.

The Contractor shall, at its own expense, wherever necessary or required, maintain fences, provide watchmen, maintain lights, place additional timber and braces, and take such other precautions as may be necessary to protect life, property, and structures, vehicles and pedestrians and shall be liable for all damages, occasioned in any way by his act or neglect or that of this agent, employees, or workmen. He shall provide access at all times to private property.

X Occupational Safety and Health Act

The applicable sections of the Occupational Safety and Health Act of 1970 (Williams-Steiger Act) shall apply and be made a part of this Contract. The Contractor's attention is particularly directed to the record keeping requirements of this Act.

XI Nondiscrimination in Employment

The Contractor agrees and warrants that, in the performance of this Contract, he will not discriminate or permit discrimination against any person or group of persons on the grounds of race, color, sex, religion, or national origin in any manner prohibited by State, Federal, County or Municipal law.

XII Personal Attention and Competent Workmen

The Contractor shall give his personal attention constantly to the faithful prosecution of the work and shall be present, either in person or by a duly authorized representative, on the site of the work continually during its progress to receive directions or instructions from the Borough of Naugatuck Inspector. The Contractor shall employ at the site, during the performance of the work, a competent superintendent or foreman who shall be satisfactory to the Borough of Naugatuck Inspector and who shall not be changed, except with the consent of the Borough of Naugatuck Inspector, unless he shall cease to be an employee of the Contractor. Such superintendent or foreman shall represent and have full authority to act for the Contractor in his absence, and all directions and instructions given such superintendent or foreman shall be as binding as if given to the Contractor.

The Contractor shall employ only competent, skillful men to do the work, and whenever the Borough of Naugatuck Inspector shall notify the Contractor in writing that any man on the work is, in his opinion, incompetent, unfaithful, disorderly, or otherwise unsatisfactory, such man shall be discharged from the work and shall not again be employed on it, except with the consent of the Borough of Naugatuck Inspector.

XIII Public Safeguards

The Contractor agrees to conduct the work at all times in such a manner that public travel

shall not be inconvenienced needlessly nor shall it be wholly obstructed at any point.

XIV Materials and Workmanship

It is the intent of the Specifications to describe fully and definitely the character of materials and workmanship furnished regarding all ordinary features and to require first-class work and materials in all particulars. For any unexpected features arising during the progress of the work and not fully covered herein, the Specifications shall be interpreted by the Borough of Naugatuck Inspector to require first class work and materials in all respects, and such interpretation shall be accepted by the Contractor.

XV Materials and Manufactured Articles

All materials and workmanship shall be subject to the approval of the Borough of Naugatuck Inspector and shall be in conformity with approved modern practice.

Unless otherwise specifically provided for in the Specifications, all materials incorporated in the work shall be new, of standard and first-class quality, and of the best workmanship and design. No inferior, or low grade, material will be either approved or accepted, and all work of assembly and construction must be done in a neat, first-class, and workmanlike manner.

XVI Unnoticed Defects

The inspection of the work and materials by the Borough of Naugatuck Inspector shall not relieve the Contractor of any of his obligations to fulfill this Contract, as herein described, and defective work shall be made good and unsuitable materials shall be rejected, notwithstanding that such work and materials had been previously overlooked by the Borough of Naugatuck Inspector and accepted or estimated for payment. If the work, or any part thereof, shall be found defective at any time before final acceptance of the whole work, the Contractor shall forthwith make good such defects, in a manner satisfactory to the Borough of Naugatuck Inspector.

XVII Care and Protection of Work

From the commencement of the work until the completion of the same, the Contractor shall be solely responsible for the care of the work covered by the Contract and for the materials delivered at the site intended to be used in the work; and all injury, damage, or loss of the same, from whatever cause, shall be made good at his expense before the final estimate is made. He shall provide suitable means of protection for all materials intended to be used in the work and for all work in progress as well as for completed work. He shall take all necessary precautions to prevent injury or damage to the work under construction by flood, freezing or inclement weather at any and all times. The methods used for this purpose shall be subject to the approval of the Borough of Naugatuck Inspector, but shall not relieve the Contractor from liability for inadequate protection of the work or materials.

XVIII Assignment of Contract

The Contractor shall have no right or power to assign this Contract, in whole or in part, nor to assign any right arising, or moneys due or to grow due thereunder, without prior written approval of the Owner.

XIX Subcontracting

The Contractor may utilize the services of specialty subcontractors on those parts of the work which, under normal contracting practices, are performed by specialty subcontractors. The Contractor shall not award the work to a subcontractor(s) without prior written approval of the Owner. The Contractor shall be fully responsible to the Owner for the acts and omissions of his

subcontractors, and of persons either directly or indirectly employed by them, as he is for the acts and omissions of persons directly employed by him.

The Contractor shall cause appropriate provisions to be inserted in all subcontracts relative to the work to bind subcontractors to the Contractor by the terms of these Contract Documents, insofar as applicable to the work of subcontractors, and to give the Contractor the same power as regards terminating any subcontract that the Owner may exercise over the Contractor under any provisions of these Contract Documents.

Nothing contained in this contract shall create any contractual relation between any subcontractor and the Owner.

XX Liability of Contractor for Employees

Each and every employee of the Contractor and each and every of his subcontractors engaged in the said work shall, for all purposes, be deemed and taken to be the exclusive servants of the Contractor and not for any purpose or in any manner in the employment of the Owner. The Contractor shall, in no manner, be relieved from responsibility or liability on account of any fault or delay in the execution of the said work, or any part thereof, by any such employee, or any such subcontractor, or any material men, whatsoever.

XXI Coordination With Other Contractors and Utilities

During the progress of the work, existing utilities may be found to be in close proximity to or in conflict with the work being installed. The Contractor shall make every effort to identify and locate these utilities before working in the area. If it is known or found that these utilities exist the Contractor shall contact the appropriate utility and alert them to the situation. Should an existing utility be found to be in close proximity to the work the Contractor shall take all the necessary precautions to protect the utilities and his work. Should existing utilities be found to conflict with the work the Contractor shall arrange with the utility company for their adjustment. No additional compensation will be made for delays, inconvenience or damage sustained by the Contractor due to interference from the above-noted utility appurtenances or the operation of locating, installing or moving them or the inability of others to perform their work in a timely manner.

XXII Permits, Laws, Codes, Ordinances and Insurance

The Contractor shall keep himself fully informed of all existing and current codes, ordinances, and regulations and Municipal, County, State or National laws in any way limiting or controlling the actions or operations of those engaged upon the work or affecting the materials supplied to or by them. He shall, at all times, observe and comply with all such valid and legally binding ordinances, laws, and regulations and shall protect and indemnify the Owner and its representatives and agents against any claim or liability arising from, or based on, any violation of the same. He shall obtain and pay for all necessary permits and pay all fees required in connection with the Contract. Contractor shall provide the types and amounts of insurance as set forth in Section 19, Information of Bidders and maintain in effect. He shall take out and carry appropriate employer's liability insurance and public liability insurance.

XXIII Patent Rights

The Contractor shall indemnify and save harmless the Owner and its officers, agents, and representatives from all claims for damages arising from the infringements, or alleged infringements, of any Letters Patent or patent rights covering any material, appliance, or device used in or upon the work or any part thereof.

XXIII Patent Rights (continued)

All royalties for patents or patent infringement claims, that might be involved in the construction or use of the work, shall be included in the Contract amount; and the Contractor shall satisfy all demands that may be made at any time for such and shall be liable for any damage or claims for patent infringements; and the Contractor shall, at his own expense, defend any and all suits or proceedings that may be instituted against the Owner for infringement, or alleged infringement, of any patent or patents involved, or alleged to be involved, in the work; and in case of any award for damages, the said Contractor shall pay such award.

XXIV Defense of Suits

The Contractor shall indemnify and hold harmless the Owner and its consultants, agents and employees from and against all claims, damages, losses, and expenses, including, but not limited to, attorney fees, ("indemnification expense") arising out of or resulting from the performance of the work or arising out of or resulting from the Contract Documents, including, without limitation, all indemnification expense regarding personal injury or death and/or damage to real or personal property or motor vehicles.

In claims against any person or entity indemnified under this section by an employee or the Contractor, a Subcontractor, anyone directly or indirectly employed by them or anyone for whose acts they may be liable, the indemnification obligation under this Section shall not be limited by a limitation on amount or type of damages, compensation or benefits payable by or for the Contractor or a Subcontractor under worker's or workmen's compensation acts, disability benefit acts or other employee benefit acts.

XXV Claims for Labor and Materials

The Contractor shall indemnify and save harmless the Owner from all claims expenses and for judgments regarding labor done or materials furnished under this Contract, or any alterations or modifications thereof, including without limitation, reasonable Attorney's fees. Contractor shall furnish the Owner with a Mechanic's Lien Waiver from all persons who have done work, or furnished materials under this Contract. In case such waiver is not furnished, an amount necessary or sufficient, within the discretion of the Owner, to meet the claims of the persons aforesaid, shall be retained, as herein specified, from the money due the Contractor under this Contract until the liabilities aforesaid shall be fully discharged or satisfactorily secured.

XXVI Completion of Work by Owner

If the work to be done under this Contract shall be abandoned by the Contractor; or if this Contract shall be assigned, or the work sublet by him, otherwise than as herein specified; or if at any time the Owner shall be of the opinion that the performance of the Contract is unnecessarily or unreasonably delayed; or if the Contractor is willfully violating any of the conditions or covenants of this Contract, or of the Specifications, or is executing the same in bad faith or not in accordance with the terms thereof; or if the work be not fully completed within the time named in this Contract for its completion, or within the time to which the completion of the Contract may be extended by the Owner, the Owner may notify the Contractor to discontinue all work, or any part thereof under his Contract, by a written notice to be served upon the Contractor as herein provided.

The Contractor shall, within five (5) days of the service of said written notice, discontinue the work, or such part thereof, and the Owner shall thereupon have the power to contract for the completion of the Contract, in the manner prescribed by law; or to place such and so many persons as it may be deemed advisable, by contract or otherwise, to work, and complete the work herein described, or such part thereof; or to take possession of and use any of the materials, plant, tools, equipment, supplies, and property of every kind provided by the Contractor for the purpose of his work; and to procure other materials and equipment for the completion of the same; and to charge the expense of said labor, materials and equipment to the Contractor.

The expense so charged shall be deducted and paid by the Owner out of such moneys as may be due, or may at any time thereafter grow due to the Contractor under and by virtue of this Contract, or any art thereof; and in case such expense shall exceed the amount which would have

XXVI Completion of Work by Owner (continued)

been payable under the Contract, if the same had been completed by the Contractor, the Contractor or his surety shall pay the amount of such excess to the Owner within five (5) days of written demand therefore; and in case such expense shall be less than the amount which would have been payable under this Contract, if the same had been completed by the Contractor, the owner shall pay such difference to the Contractor within five (5) days of written demand.

XXVII Partial and Final Estimates

On, or about, the last day of the month, the Borough of Naugatuck Inspector shall make an approximate estimate of the value of the work done and of the materials incorporated into the work.

The Owner will pay the Contractor, within 30 days of receipt of an estimate, ninety-five percent (95%) of the total estimated value of the work done, as estimated by the Borough of Naugatuck Inspector less previous payments. Partial payments will not be made whenever the amounts of the estimate or estimates of work done since the last previous estimate are less than \$2,000.00.

The Borough of Naugatuck Inspector shall, as soon as practicable after the completion of work, make a final certificate of the entire amount of the work done under this Contract, and the value thereof, and the Owner shall, within thirty (30) days after such final estimate is approved, pay the entire sum so found to be due hereunder, after deducting there from all previous payments and also all percentages and deductions to be retained under any of the provisions of this Contract.

Before payment of each estimate, the Contractor shall provide the Owner with a mechanic's lien waiver from the Contractor and all persons who have done work or furnished materials under this Contract.

XXVIII Extra Work

The Contractor shall and will do any and all work and furnish any and all materials not herein provided for which, in the opinion of the Borough of Naugatuck Inspector, may be found necessary or advisable for the proper completion of the work or the purposes thereof, or any modifications or alternations thereto.

All extra work and materials shall be ordered in writing by the Borough of Naugatuck Inspector, and in no case will any work or materials in excess of the amount shown in the Plans and Specifications be paid for unless so ordered. Additionally, if the extra work requires additional cost, a purchase order must be issued prior to work commencing. No claim for delay shall be made as a result of this process. No voucher, claim or charge against the Borough shall be paid, nor is the Borough liable for any voucher, claim or charge unless a purchase order is issued. The Contractor further agrees that he shall accept, as full compensation for such extra work and materials, the unit price bid, in the case of Items covered by unit prices in the Proposal, and no more; and for such Items as are not covered by a unit price, he shall accept as full compensation:

1. an agreed on lump sum price, or
2. the reasonable cost, as determined by the Borough of Naugatuck Inspector, of all

necessary labor, including insurance and payroll taxes, equipment rental, and materials, plus fifteen percent (15%) which covers supervision, the use of tools and plant, and other overhead expenses and profit.

The equipment rental charge shall be at prevailing rates usually paid locally but shall in no case exceed the amount prorated on the basis of the monthly equipment rental rates compiled by the Associated Equipment Distributors.

When extra work is performed by an approved subcontractor, the Contractor shall be entitled to five percent (5%) of the direct cost of the subcontractor's work to cover his overhead expenses and profit.

The Contractor agrees to prosecute such extra work with all reasonable diligence and to employ thereon competent men. The Contractor shall give the Borough of Naugatuck Inspector access to all accounts, bills, payrolls, and vouchers relating to extra work not covered by unit prices, and he agrees that he shall have no claim for compensation for such extra work in the case of items not covered by unit prices, unless a statement in writing of the actual cost of the same, fully itemized as to labor and materials, is presented to the Borough of Naugatuck Inspector before the fifteenth (15th) day of the month following that during which each specific order was complied with by him.

XXIX Payment

The Owner, in consideration of the faithful performance by the Contractor of all and singular his covenants, promises, and agreements contained herein, agrees to pay the Contractor for the full completion by him of the work embraced in this Contract, in the manner and within the time herein specified and limited, and to the satisfaction and approval of the Borough of Naugatuck Inspector, the prices stipulated in the said Proposal hereto attached, such payment to be made at the times and in the manner and upon the conditions herein expressly provided. The Owner also agrees to pay in addition such amounts as may be agreed upon for modifications and for extra work.

XXX Guarantee

The Contractor guarantees that the work done under this Contract and the materials furnished by him and used in the construction of the same are free from defects or flaws. The guarantee is for a term of one (1) year from, and after, the date upon which the final estimate of the Borough of Naugatuck Inspector is formally approved by the Owner. It is hereby agreed and understood that this guarantee shall not include making any repairs made necessary by any cause or causes other than defective materials furnished by, or defective work done by, the Contractor.

XXXI Repairs for One (1) Year

The said party of the second part further agrees that if, at any time during the period of one (1) year from the date of the final estimate of the work herein contracted for, any part of the work done under this Contract shall be deemed by the Borough of Naugatuck Inspector to require repairing under the aforesaid Contractor's guarantee, then the said Owner shall notify the said Contractor to make the repairs so required at no expense to the Owner.

Such replacements, or repairs, shall be undertaken by the Contractor within twenty-four (24) hours after service of notice. If the Contractor unnecessarily delays or fails to make the ordered replacements or repairs within the time specified, or if any replacements or repairs are of such nature as not to allow for the time delay incident to the service of a notice, then the Owner will have the right to make such replacements or repairs, and the expenses thereof shall be paid by the Contractor.

XXXII Rate of Progress and Time of Completion

The Contractor shall commence work within ten (10) calendar days of the date of the Notice to Proceed. The rate of progress shall be such that the whole work shall be performed and the grounds cleared up in accordance with the Contract and Specifications within thirty (30) calendar days unless extensions of time shall be made for the reasons, and in the manner, stated under Article XXXIII, "Extension of Time".

The above calendar days includes time for the Contractor to obtain approval of a Erosion and Sediment Control Plan, as applicable.

XXXIII Extension of Time

The Contractor expressly covenants and agrees that, in undertaking to complete the work within the time mentioned, he has taken into consideration, and made allowance for, all of the ordinary delays and hindrances incidental to such work, whether growing out of delays in securing materials or workmen or otherwise. Should the Contractor, however, be substantially delayed in the prosecution and completion of the work by any changes, additions, or omissions therein ordered in writing by the Borough of Naugatuck Inspector, or by fire, lightning, earthquake, tornado, cyclone, riot, insurrection, or war, or by the abandonment of the work by the workman engaged therein through no fault of the Contractor, or by the discharge of all or any material number of workmen in consequence of difficulties arising between the Contractor and such workmen, or by the neglect, delay, or default of any other contractor of the Owner, then the Contractor may, within five (5) days after the occurrence of the delay for which he claims allowance, notify the Borough of Naugatuck Inspector thereof in writing, and thereupon, and not otherwise, the Contractor shall be allowed such additional time for the completion of the work as the Borough of Naugatuck Inspector, in his discretion, shall award in writing, and his decision shall be final and conclusive upon the parties.

XXXIV Damages for Failure to Complete on Time

The Contractor shall pay to the Owner for each and every calendar day (including Saturdays, Sundays, and holidays) that he shall be in default in completing the entire work in the time stipulated in Article XXXII, or within the extension of time he may be granted as provided in Article XXXIII, the sum of Two Hundred Dollars (\$200.00) per day. This sum is hereby agreed upon not as a penalty but as liquidated damages which Owner will suffer by reason of such default, time being of the essence of the Contract and a material consideration thereof. The Owner shall have the right to deduct the amount of any such damages from any monies due the Contractor under this Contract.

XXXV No Waiver of Rights

No certificate given or payment made under this Contract, except the final certificate or final payment, shall be evidence of the performance of the Contract either wholly or in part, and no payment shall be construed to be an acceptance of defective work or improper materials. No act of the Owner or of the Borough of Naugatuck Inspector, or of any representatives of either of them in inspecting the work, nor any extension of time for the completion of the work, shall be regarded or taken as an acceptance of such work, or any part thereof, or materials used therein or thereof, either wholly or in part; but such acceptance shall be evidenced only by the final certificate of the Borough of Naugatuck Inspector.

Before any final certification shall be allowed, the Contractor shall be required, and he hereby agrees, to sign and attest on said certificate a statement that he accepts the same in full payment and settlement of all claims on account of work done and material furnished under this Contract, and furthermore, that all claims for materials provided or labor performed have been paid and satisfied in full. No waiver of any breach of this Contract by the Owner or anyone

acting for it, or on its behalf, shall be held as a waiver of any other or subsequent breach thereof.

XXXVI Mandatory Negotiation

Contractor and the Owner agree that they will attempt to negotiate in good faith any dispute of any nature arising under this contract. The parties shall negotiate in good faith at not less than two negotiation sessions prior to seeking any resolution of any dispute under the provisions of arbitration paragraph of this contract. Each party shall have the right to legal representation at any such negotiation session.

XXXVII Dispute Resolution

Any dispute or question arising under the provisions of this contract, which has not been resolved under the mandatory negotiation paragraph of this contract, shall be resolved by litigation in the Connecticut superior Court

XXXVIII Owner's Right to Use

The Owner reserves the right to use or occupy any portion of the work considered by the Borough of Naugatuck Inspector as ready for use or occupancy. Such use or occupancy shall not be held, in any way, as final acceptance of the work or any portion thereof, or as a waiver of any portion of this Contract.

XXXIX Verification of Data

The quantities of work to be done and the materials to be furnished under this Contract, as given in the accompanying "Information for Bidders" and on the Proposal form, are approximate estimates for the purpose of comparing bids on a uniform basis. Neither the Owner nor the Borough of Naugatuck Inspector are to be held responsible for the data or information given relative to said quantities or that given on the Plans relative to existing conditions. The Contractor has judged for himself as to such quantities and as to other circumstances affecting the cost of the performance of this Contract, and he shall not at any time assert that there was any misunderstanding in regard to the character or amount of work to be done and materials and labor to be furnished.

XXXX Contractor's Wage Certification Form

If applicable the Contractor or his authorized agent will be required to sign the Contractor's Wage Certification Form at the time of Contract execution.

XXXXI Verbal Statements Not Binding

It is understood and agreed that the written terms and provisions of this Agreement shall supersede all prior verbal statements of the Borough of Naugatuck Inspector or other representatives of the Owner, and such statements shall not be effective or be construed as entering into or forming a part of, or altering in anyway whatsoever, the written Agreement.

XXXXII Final Estimate Constitutes Release

It is agreed that acceptance by the Contractor of the last payment made, under the provisions of Article XXVII, shall operate as and shall be a release to the Owner, and every agent thereof, from all claims and liability to Contractor for anything done or furnished for, or relating to, the work or for any act or neglect of the Owner or of any agent thereof, except any claim against the Owner for the remainder, if any, of the amounts kept or retained by the Owner as percentages or deductions.

No payment, however, final or otherwise, shall operate to release the Contractor or his sureties from any obligations under this Contract.

XXXXIII Delays or Termination by Governmental Authorities

Notwithstanding any other provision(s) of this contract, the parties agree that in the event of a stop work order from the State Department of Transportation, Department of Environmental Protection, or any other State or Federal agency, no additional compensation will be made by Owner to Contractor for delays, inconvenience or damage sustained by Contractor due to such order, including, without limitation, damages for loss of use of equipment or idle equipment. Similarly, in the event of a termination of the project by the State DOT, DEP or any other State or Federal agency, no additional compensation will be made by Owner to Contractor for the termination, or for any delay, inconvenience or damage sustained by Contractor due to such termination, including, without limitation, damages for loss of use of equipment or idle equipment. In the event of such termination, the Borough of Naugatuck Inspector shall prepare a final certificate for the entire amount of work done up to the effective date of termination. The provisions of Sections XXX (Guarantee) and XXXI (Repair) shall apply to all work completed as of the effective date of any stop Work order, as if the effective date was the date upon which the final estimate of the Borough of Naugatuck Inspector is formally approved by the Borough.

XXXXIV Validity of Agreement

The provision of this Agreement shall be binding upon the Parties and their respective successor or assigns.

IN WITNESS WHEREOF, the said parties hereto have caused this instrument to be signed by their respective duly constituted officers, attested, and sealed pursuant to proper resolutions.

Signed and sealed
in the presence of

Borough of Naugatuck
Mayor

(Duly Authorized)
Contractor

CERTIFICATE AS TO CORPORATE PRINCIPAL

I, _____ certify that I am the _____ of the Corporation named as Contractor in the within bond; that _____, who signed the said bond on behalf of the Contractor was then _____ of said corporation; that I know his signature, and his signature thereto is genuine; and that said bond was duly signed, sealed, and attested to for and in behalf of said corporation by authority of this governing body.

(Corporate
Seal)

Title

SECTION F

PERFORMANCE BOND

PERFORMANCE BOND

KNOW ALL MEN BY THESE PRESENTS: that

(Name of Contractor)

(Address of Contractor)

a _____, hereinafter called Principal and
(Corporation, Partnership, or Individual)

(Name of Surety)

(Address of Surety)

hereinafter called Surety, are held and firmly bound unto

(Name of Owner)

(Address of Owner)

hereinafter called OWNER, in the penal sum of _____ Dollars,
\$(_____) in lawful money of the United States, for the payment of which sum well and truly to be made, we bind ourselves, successors, and assigns, jointly and severally, firmly by these presents.

THE CONDITION OF THIS OBLIGATION is such that whereas, the Principal entered into a certain contract with the OWNER, dated the ____ day of _____, 20____, a copy of which is hereto attached and made a part hereof for the construction of:

NOW, THEREFORE, if the Principal shall well, truly and faithfully perform its duties, all the undertakings, covenants, terms, conditions, and agreements of said contract during the original term thereof, an any extensions thereof which may be granted by the OWNER, with or without notice to the Surety and during the one year guaranty period, and if he shall satisfy all claims and demands incurred under such contract, and shall fully indemnify and save harmless the OWNER from all costs and damages which may suffer by reason of failure to do so, and shall reimburse and repay the OWNER all outlay and expense which the OWNER may incur in making good any default, then this obligation shall be void; otherwise to remain in full force and effect.

PROVIDED, FURTHER, that the said surety, for value received hereby stipulates and agrees that no change, extension of time, alteration or addition to the terms of the contract or to WORK to be performed thereunder or the SPECIFICATIONS accompanying the same shall in anyway affect its obligation on this BOND, and it does hereby waive notice of any such change,

extension of time, alteration or addition to the terms of the contract or to the WORK or to the SPECIFICATIONS.

PROVIDED, FURTHER, that no final settlement between the OWNER and the CONTRACTOR shall abridge the right of any beneficiary hereunder, whose claim may be unsatisfied.

IN WITNESS WHEREOF, this instrument is executed in _____ counterparts each one of Which shall be deemed an original, this the _____ day of _____, 200__.

ATTEST:

(Principal) Secretary

By _____ Principal _____(s)

(SEAL)

(Witness as to Principal)

(Address)

(Address)

Surety

ATTEST:

(Surety) Secretary

(SEAL)

Witness as to Surety

By _____ Attorney-in-Fact

(Address)

(Address)

NOTES: If CONTRACTOR is Partnership, all partners should execute BOND.

IMPORTANT: Surety companies executing BONDS must appear on the Treasury Department's most current list (Circular 570 as amended) and be authorized to transact business in the state where the PROJECT is located.

SECTION G

PAYMENT BOND

PAYMENT BOND

KNOW ALL MEN BY THESE PRESENTS: that

(Name of Contractor)

(Address of Contractor)

a _____, hereinafter called Principal and
(Corporation, Partnership, or Individual)

(Name of Surety)

(Address of Surety)

hereinafter called Surety, are held and firmly bound unto

(Name of Owner)

(Address of Owner)

hereinafter called OWNER, in the penal sum of

_____ Dollars, \$(_____)

in lawful money of the United States, for the payment of which sum well and truly to be made, we bind ourselves, successors, and assigns, jointly and severally, firmly by these presents.

THE CONDITION OF THIS OBLIGATION is such that whereas, the Principal entered into a certain contract with the OWNER, dated the _____ day of _____, 20__ , a copy of which is hereto attached and made a part hereof for the construction of:

NOW, THEREFORE, if the Principal shall well, truly and faithfully perform its duties, all the undertakings, covenants, terms, conditions, and agreements of said contract during the original term thereof, an any extensions thereof which may be granted by the OWNER, with or without notice to the Surety and during the one year guaranty period, and if he shall satisfy all claims and demands incurred under such contract, and shall fully indemnify and save harmless the OWNER from all costs and damages which may suffer by reason of failure to do so, and shall reimburse and repay the OWNER all outlay and expense which the OWNER may incur in making good any

default, then this obligation shall be void; otherwise to remain in full force and effect.

PROVIDED, FURTHER, that the said surety, for value received hereby stipulates and agrees that no change, extension of time, alteration or addition to the terms of the contract or to WORK to be performed thereunder or the SPECIFICATIONS accompanying the same shall in anyway affect its obligation on this BOND, and it does hereby waive notice of any such change, extension of time, alteration or addition to the terms of the contract or to the WORK or to the SPECIFICATIONS.

PROVIDED, FURTHER, that no final settlement between the OWNER and the CONTRACTOR shall abridge the right of any beneficiary hereunder, whose claim may be unsatisfied.

IN WITNESS WHEREOF, this instrument is executed in _____ counterparts each one of which shall be deemed an original, this the _____ day of _____, 20__.

ATTEST:

_____	By _____(s)
(Principal) Secretary	Principal
(SEAL)	
_____	_____
(Witness as to Principal)	(Address)
_____	_____
(Address)	

ATTEST:

_____	_____
(Surety) Secretary	Surety
(SEAL)	
_____	By _____
Witness as to Surety	Attorney-in-Fact
_____	_____
(Address)	(Address)

IMPORTANT: Surety companies executing BONDS must appear on the Treasury Department's most current list (Circular 570 as amended) and be authorized to transact business in the state where the PROJECT is located.

SECTION H

Specifications

PART 1 - GENERAL

1.1 GENERAL REQUIREMENTS

- A. Work of this Section consists of an automatic irrigation system, but is not limited to the following:
 - 1. Automatic irrigation system with electric control including piping, fittings and accessories.
 - 2. Booster Pump with related plumbing and electrical (Base bid).
 - 3. Backflow preventer and enclosure.
 - 4. Rain Sensor with related wiring.
 - 5. Moisture sensors with related wiring.
 - 6. Controller with related wiring and conduit, electrical wiring (Base bid).
 - 7. Hydrometer (Base bid).
 - 8. Grounding of irrigation system.
 - 9. Testing and instruction.
 - 10. Excavating and backfilling irrigation system work.
 - 11. Maintenance and warranty
 - 12. Booster Pump with integrated Baseline controller and hydrometer and related plumbing and electrical (Alternate bid).
- B. Contractor shall Contact "Call Before You Dig" prior to any excavation. Particular attention shall be made to the underground utility services.

1.2 PRE-INSTALLATION MEETING

- A. Attend a pre-installation meeting. Meeting to be held at a time requested by the construction manager to coordinate all trades and requirements of this Section. Representatives from Construction Manager, Irrigation Design Consultant, the Owner and Irrigation Contractor are to attend.

1.3 REFERENCES

- A. NEC — National Electric Code, current edition.
- B. UPC — Uniform Plumbing Code, current edition.
- C. ASTM — ASTM International:
 - 1. B 3 — Specification for Soft or Annealed Copper Wire.
 - 2. D 698 — Test Method for Laboratory Compaction Characteristics of Soil Using Standard Effort.
 - 3. D 1557 — Test Method for Laboratory Compaction Characteristics of Soil Using Modified Effort.
 - 4. D 1784 — Specification for Rigid PVC (polyvinyl chloride) Compounds and CPVC (chlorinated polyvinyl chloride) Compounds.
 - 5. D 1785 — Specification for PVC (polyvinyl chloride) Plastic Pipe, Schedule 40.
 - 6. D 2287 — Specification for Nonrigid Vinyl Chloride Polymer and Copolymer Molding and Extrusion Compounds.
 - 7. D 2241 — Specification for PVC (polyvinyl chloride) Pressure-Rated Pipe (SDR Series).

8. D 2464 — Specification for Threaded PVC (polyvinyl chloride) Plastic Pipe Fittings, Schedule 80.
9. D 2466 — Specification for PVC (polyvinyl chloride) Plastic Pipe Fittings, Schedule 40.
10. D 2564 — Specification for Solvent Cements for PVC (polyvinyl chloride) Plastic Piping Systems.
11. ANSI — American National Standards Institute: NSF 14— Plastics Piping Components and Related Materials.

1.4 DEFINITIONS

- A. The following are industry abbreviations for irrigation materials.
 1. Acceptance, Acceptable, or Accepted: Acceptance by the Irrigation Consultant in writing.
 2. Excessive Compaction: Planting area soil or soil mix compaction greater than 75 percent of maximum dry density as determined by ASTM D 1557.
 3. Deleterious Material: The term "deleterious material" shall refer to any rock, shale, stones, organic matter or trash not suitable for use as backfill.
 4. PVC: Polyvinyl Chloride.
 5. HDPE: High Density Polyethylene.
 6. SDR: Standard Dimensional Ratio.
 7. AWG: American Wire Gauge.

1.5 SUBMITTALS

- A. Product Data: Manufacturer or supplier's descriptive literature including installation instructions, for each specified product.
- B. Submit all product warranties to Owner's representative.
- C. Credentials: Name and qualifications of the irrigation contractor who is licensed by the State of Connecticut including at least three (3) comparable projects of similar work and scope that the Contractor has completed within the last three (3) years with job locations, names of owners and architects, their phone numbers, and dates on which the work on each project was started and completed.
- D. Submit State of Connecticut irrigation license number.
- E. Certified Irrigation Contractor: Submit proof of current Irrigation Association Certified Irrigation Contractor (CIC) status.
- F. Certifications: Written certification from each product manufacturer or supplier stating that their product conforms to the specified requirements and that all products do not contain hazardous materials.
- G. Shop Drawings:
 1. Show layout of irrigation system adjusted with layouts of on-site design conditions and plantings.
- H. Samples: When requested by the Owner's Representative submit each irrigation system component and other item(s) related to the work to confirm product characteristics.
- I. Operating and Maintenance Manual: Three (3) manuals describing in detail the step-by-step procedures required for system start-up, operation and shut down of the entire irrigation system. Operating manuals shall include the manufacturer's name, model number, parts list and brief description of all equipment and their basic operating features. Maintenance manuals shall list

routine maintenance procedures, possible breakdowns and repairs, and troubleshooting guides. Index and arrange the manuals in proper order; include copies of all product literature and their warranties.

- J. Warranty: On company letterhead submit a written warranty in the following format:
1. Warranty for ** NAME OF PROJECT** irrigation system we hereby guarantee that the irrigation system we have furnished and installed for **NAME OF PROJECT** is free from defects in materials and workmanship, and the work has been completed in accordance with the Contract Drawings and Specifications, ordinary wear and tear and unusual abuse, or neglect expected. We agree to repair or replace any defects in material or workmanship which may develop during the period of one year from date of the rendition of Certificate of Final Completion and to repair or replace any damage resulting from repairing or replacing of such defects at no additional cost.
- K. GPS Construction Record Drawing:
1. GPS As-Built Drawings to consist of the following: Controllers, Sprinklers, Spray heads, Quick coupling valves, Isolation valves, Automatic valve assemblies, mainline pipe routing, lateral pipe routing, splice boxes, grounding locations with OHM readings, communication cable routing, 2-wire path with decoder numbers. All pipe and wire to have size indicated.
 2. Prepare "Construction Record Drawings" for irrigation system using a computer process based upon AutoCAD, release 2017 software and drawn at a scale of 1"=20'-0". Legibly mark drawings to record actual construction locations. Identify field changes of dimension, detail and changes made by Change Order or Field Directives.
 3. Submit (1) CD-ROM disks with digital drawing (.dwg) file(s) and PDF's suitable for reproduction.
 4. Submit one (1) print on 24lb bond paper of the "Construction Record Drawings" showing the actual construction of the irrigation system.
 5. Submit "Construction Record Drawings" prior to final review and acceptance.
- L. Controller Drawings:
1. Controller drawings shall be a reproduction of the construction record drawing reduced and printed on 8½" x 11" 24lb bond paper. Drawings shall be legible. If necessary, use multiple sheets of paper and place drawings back to back.
 2. Drawings shall show all irrigation zones highlighted in a different color solid hatch pattern with the designated valve schedule.
 3. Seal controller drawings in 10 mil plastic laminate. When multiple drawings are required punch a hole in the upper left had corner of the laminate and connect with a key chain loop.
 4. Submit two (2) drawings for each controller.
- M. Irrigation Schedule:
1. Using data obtained from the water audit the Certified Landscape Irrigation Auditor shall create a typewritten schedule on 8 ½" x 11" white paper listing each valve number, type of sprinkler (rotor, spray, drip), description of that zone, days to water and daily runtimes for each irrigation month. Irrigation run times based on historical evapotranspiration and rainfall data.

2. Example:

Zone	Type	Days	Description	April	May	June	Jul	Aug	Sept	Oct
1	Drip	MWF	Front Bed	15:00	17:00	25:00	25:00	30:00	18:00	8:00

2	Spray	MWF	Rear Lawn	5:00	6:00	8:00	12:00	13:00	9:00	6:00
---	-------	-----	-----------	------	------	------	-------	-------	------	------

3. Schedule shall include the following note: Irrigation runtimes are based on Historical data and should be used only as a guide. All irrigation runtimes should be adjusted accordingly based on actual climatic conditions.
4. Seal irrigation schedule in 10 mil plastic laminate.
5. Submit two (2) irrigation schedules for each controller.

1.6 COORDINATION

- A. Thoroughly coordinate and schedule the work of this Section with all trades involved to prevent interferences, and to allow adequate time at the proper stage of construction to properly perform all work of this Section.
- B. Coordinate location of all piping and sleeves to be installed under walkway and driveway pavements.

1.7 QUALITY ASSURANCE

- A. It is the intent of these Specifications and Drawings to provide for a complete installation. Therefore, any items not specifically noted but, reasonably necessary for a complete installation, shall be furnished. The system is to efficiently and uniformly irrigate all areas and perform as required by the Contract Documents. The irrigation system shall be fully automatic with an electric control.
- B. Obtain and pay for all required inspections, permits, and fees. Provide notices required by governmental authorities.
- C. Qualifications:
 1. Experienced Contractors are required who are thoroughly trained and experienced in the skills required to install irrigation systems. Contractors to have a minimum of five (5) years' experience in the installation of site irrigation and be regularly engaged in and which maintains a regular work force in the installation of site irrigation.
 2. A qualified superintendent shall be present during the installation.
 3. Irrigation Contractor shall be a current Irrigation Association Certified Irrigation Contractor (CIC).
 4. Materials, equipment, and methods of installation will comply with the applicable requirements of the authorities having jurisdiction including the following codes and standards:
 - a. National Fire Protection Association, (NFPA): National Electrical Code.
 - b. American Society for Testing and Materials, (ASTM).
 - c. National Sanitation Foundation, (NSF).
 - d. American Society of Agricultural Engineers, (ASAE).
- D. Licenses:
 - a. A licensed Plumber shall make all plumbing connections. A licensed Electrician shall perform connections to 120 VAC power supplies.

1.8 SITE CONDITIONS

- A. Locate and identify installed and existing underground and overhead services and utilities within the contract limits. Install adequate means of protection of utilities and services designated to remain. Repair utilities damaged during work operations of this Section at the Contractor's expense.

- B. When uncharted or incorrectly charted underground piping or other utilities and services are encountered during site work operations, notify the Owner's Representative and applicable utility company immediately to obtain procedural directions.
- C. Cooperate with the applicable utility company in maintaining active services in operation.
- D. Locate, protect, and maintain bench-marks, monuments, control points and project engineering reference points. Re-establish disturbed or destroyed items at Contractor's expense.
- E. Protect existing and newly installed trees, plants, lawn areas, and other features designated to remain as part of the landscape work.
- F. Examine the areas and conditions under which site work is to be performed. Promptly notify the Owner's Representative of unexpected sub-surface conditions. Do not proceed with the work until unsatisfactory conditions are corrected.
- G. Perform work operations and the removal of debris and waste materials to assure minimum interference with walks and other adjacent site features.
- H. Protect existing paving and other services or facilities on site from damage caused by work operations of this Section. Repair and restore damaged items to original condition.
- I. Obtain governing authorities written permission when required to close or obstruct streets, walks and adjacent facilities. Provide alternate routes around closed or obstructed streets, walks and adjacent facilities. Provide alternate routes around closed or obstructed traffic ways when required by governing authorities.
- J. Failure on part of the Irrigation Consultant to reject work in the course of operations or during inspection of work is to not be interpreted as acceptance of work not in conformance with these specifications. Correct improper work or materials whenever discovered.

1.9 WARRANTY

- A. Warranty the entire irrigation system and all related equipment and accessories for a period of one (1) year from the date of rendition of the Certificate of Final Completion against all defects in workmanship and material.
- B. The warranty period will commence upon final acceptance by the Owner for a complete system and/or any portion thereof has been put into operation and acceptable to the Owner's Representative.

1.10 MAINTENANCE

- A. During the warranty period, maintain the irrigation system to ensure complete operation of the entire irrigation system. Adjust and repair all settled piping, trenches and sprinkler heads. Correct all defective or damaged work as soon as possible.
- B. Return to the site during the subsequent fall season(s) (before October 30th) and winterize the entire system. Drain all water from the system via compressed air and demonstrate to the Owner's personnel the proper procedures for the system winterization.
- C. Return to the site during the subsequent spring season(s) (before April 15th) and start-up the system. Demonstrate to the Owner the proper procedures for the system start-up, operation, and maintenance.
- D. System maintenance to begin immediately upon Substantial Completion. Provide continuing maintenance of the irrigation system, as necessary, throughout the installation of the irrigation system.

1.11 DELIVERY, STORAGE, AND HANDLING

- A. Deliver the irrigation system components in the manufacturer's original undamaged and unopened containers with labels intact and legible.

- B. Deliver plastic piping in bundles, packaged to provide adequate protection of pipe ends, both threaded or plain.
- C. Handle materials to prevent damage.
- D. Store materials to protect from sunlight, temperature variation and weather.
- E. Provide secure, locked storage for valves, sprinkler heads, and similar components that cannot be immediately replaced, to prevent installation delays.

PART 2 PRODUCTS

2.1 MANUFACTURERS

- A. Apollo Ball Valve, Pageland South Carolina
- B. Ashcroft Gauges, Stratford, Connecticut
- C. Baseline, Boise, Idaho
- D. Dura Plastic Products; Beaumont, California
- E. Elchen Industries, Inc. (Turf-Tite), Dallas, Texas
- F. Goodall Rubber Company, Trenton, New Jersey
- G. Harrington Corporation, Lynchburg, Virginia
- H. Hunter Industries, San Marcos, California
- I. IPEX Inc Beverly, Massachusetts
- J. JM Eagle, Livingston, New Jersey
- K. Lasco Industries, Anaheim, California
- L. Leemco, Colton, California
- M. Maclean Highline Access Boxes, Fort Mill, South Carolina
- N. Munro Pumps, Grand Junction, Colorado
- O. Oldcastle Enclosure Solutions. Auburn, Washington
- P. Paige Electric Corp., Union, New Jersey
- Q. Rainbird, Glendora, California
- R. 3M Corporation, Electrical Products Division, St. Paul, Minnesota
- S. Watertronics, Hartland Wisconsin

2.2 MATERIALS

- A. All materials and equipment used in the construction work shall furnished by the Contractor. All material and equipment furnished by the Contractor shall new, of the kind and type specified, of good quality, and shall delivered to the site in good condition. All materials shall be protected by the Contractor until incorporated in the work and finally accepted by the Owner.
- B. Water Service and Meter:
 - 1. Water service and meter to be provided by the Borough of Naugatuck.
- C. Backflow Preventer:
 - 1. Backflow preventer shall be 3" inch (3") model LF886V-OS&Y (N-pattern) with flanged connections and OS&Y gate valves as manufactured by Watts/Febco or approved equal.

D. Backflow Preventer Enclosure:

1. The backflow enclosure shall be of a vandal and weather resistant nature manufactured entirely of marine grade aluminum alloy 5052-H32, with a wall thickness of one eighth inch. The mounting base shall be manufactured entirely of stainless steel. The main housing shall be of solid sheet construction punched on the sides with a rectangular pattern for viewing backflow operation. The enclosure shall be a center split design having mounting lips on each end. Backflow preventer enclosure shall be model SBBC- 40ALHP high profile, 21.5" x 38" x 37.5" high as manufactured by V.I.T. Products Inc.
2. Furnish and install weather resistant keyed lock with four (4) keys.

E. Booster Pump System:

1. Booster pump system shall be a prefabricated system, pre-piped, pre-wired and mounted on a steel skid base minimum three inch (3") welded angle iron or channel brackets, hot dipped galvanized, with a minimum 9/16-inch holes at each corner for bolting to concrete with anchors.
2. Field assembled pump systems are not acceptable.
3. Booster pump (Base Bid) station to be a variable speed packaged pump station rated for 100 GPM @ 40 PSIG boost at station discharge; 3600 RPM 208/1/60 FV, horizontal NEMA faced ODP motors, model WMBV-5000-2-5-208-1-100-40 as manufactured by Watertronics
4. Booster pump (Alternate Bid) station shall be a variable speed packaged pump station rated for 100 GPM @ 40 PSIG boost at station discharge; 3600 RPM 208/1/60 FV, horizontal NEMA faced ODP motors, integrated baseline controller and hydrometer model SCSUL085CEGXM6XX as manufactured by Munro or approved equal.

F. Controller (Base Bid):

1. The Controller to consist of a two-wire, Decoder based controller, with internal cellular communication package. The controller shall be pedestal mounted stainless-steel enclosure.
2. Controller shall be Baseline model BL-3200-P-SS-CM with super strong stainless steel enclosure or approved equal.
3. Include Basemanager Plus model BL-BMW2-PLUS. Include 3-year service plan
4. Include account set-up and communication activation for irrigation controller.
5. Include (2) two instructional meetings with the Owners designated personnel and the Manufacturers' Authorized Representative. These meetings are to occur upon completion of the irrigation system installation.

G. Controller (Alternate Bid):

Controller shall be Baseline model BL-3200-XS-CM preinstalled in Munro Pump Station.

H. 2-Wire Path:

1. Communication wire shall be double jacketed #14-2 conductor cable specially designed for use with the two-wire control systems, suitable for direct burial. The conductors shall be tin coated, soft drawn, annealed, solid copper conforming to ASTM 33 with 4/64" thick PVC (polyvinyl chloride) insulation, conforming to UL Standard #493 for thermoplastic-insulated style UF (Underground Feeder), rated at 60- degree C. Wire shall be Paige electric model # P7296D or approved equal.

I. Valve Decoders:

1. Line decoder shall be a fully programmable, direct bury decoder that provides an interface between the 2- wire controller and automatic valve. The output of the decoder shall be 24

VAC. Approved valve decoders shall be models BL-5201 and BL-5202 as manufactured by Baseline, Inc. or approved equal.

J. Sensor Decoders:

1. Flow bicoder shall be a fully programmable direct bury decoder that provides a direct interface between the Baseline controller and flow sensor and N.O. master valve. Flow bicoder shall be model BL- 5304NOMV as manufactured by Baseline, Inc. or approved equal.

K. 24V Electrical Equipment:

1. Low voltage (24 VAC) wire-splice kits shall be UL listed Paige DBM or 3M DBR/Y-6 or approved equal.
2. Twist-on wire connectors shall be 3M – Performance plus connectors (OB+, TR+ or BG+), or equal – size in accordance to wire AWG used.
3. Conduit for Low Voltage Wiring:
 - a. Conduit for 2-wire path (low voltage wiring) shall be rigid Schedule 40 non-metallic conduit and fittings conforming to NEMA TC-2, Federal specification WC1094A and UL 651 specifications. Fittings are manufactured to NEMA TC-3, Federal specification WC1094A and UL514B. Conduit shall be rated for use for underground, encased or exposed applications in accordance with the National Electrical Code (Article 347). Conduit shall be model Plus 40 as manufactured by Carlon or approved equal.
4. Conduit sealant shall be model FST-Mini duct sealant as manufactured by American Polywater Corporation or approved equal.

L. Grounding/Surge Protection:

1. Ground rods shall be 5/8" by 8' copper clad steel rods. Ground rods shall be Paige Electric model #182000 or approved equal.
2. Grounding plates shall be 4" x 3' x 0.0625" (101.6 mm x 2.44 m x 0.9 mm). A 10-foot (3.05 m) continuous length of 10 AWG, green insulated, with extruded yellow stripe, solid bare copper wire is welded to the plate. Grounding plate shall be Paige Electric model #182201IC or approved equal.
3. Earth grounding wire shall be 6/1 AWG, green insulated, solid bare copper wire. Paige Electric model #150854 or approved equal.
4. All grounding connectors shall be of the Cadweld "One Shot" fuse type – Model GR1161GPLUS (Paige Electric model #1820037P) and Model GT1161GPLUS (Paige Electric model #1820039P) or approved equal. Connections shall be made utilizing the Cadweld Battery Control Unit, Paige Electric model # PLUSCU or approved equal.
5. Earth contact material for each grounding plate shall be two (2) 50lb bags of "PowerSet" for loose soils, Paige Electric model #1820058 or "PowerFill" for clay soils, Paige Electric model #1820059 or approved equal.
6. Primary 120 VAC power lightning surge arrestor with visible green LED indicator shall be Paige Electric model #250090LED or approved equal. Furnish and install Paige Electric model #250090BRKT mounting bracket or approved equal
7. Field Surge Suppression Device shall be model BL-LA01 as manufactured by Baseline Inc or approved equal.

M. Sleeves:

1. Sleeves shall be Schedule 80 PVC pipe w/solvent weld coupling as manufactured by Ipex or approved equal.

2. Furnish and install separate sleeve for piping and wire.
 3. Furnish and install PVC sleeves two times (2x) the diameter of the pipe or conduit.
- N. Pipes and Tubes:
1. All pipe shall be continuously and permanently marked with manufacturer's name or trademark, materials size and schedule or type of pipe, working pressure at 73 degrees F. and National Sanitation Foundation (NSF) approval.
 2. The pipe shall contain no recycled compounds except that generated in the manufacturer's own plant from resin of the same specification from the same raw materials.
 3. Pipe homogenous throughout and free from visible cracks, holes, foreign materials, blisters, wrinkles, and dents.
 4. Main line piping shall be HDPE SDR-11 (200 psi WPR) (Butt Fusion) High Density Polyethylene Pipe (HDPE). Pipe and tubing shall be manufactured from a PE4710 resin listed with the Plastic Pipe Institute (PPI) as TR-4. The PE 4710 resin material will meet the specifications of ASTM D 3350-09 with a minimum cell classification of PE 445474C. Pipe shall be manufactured to the dimensions and requirements of ASTM F714 or ASTM D3035. The pipe shall contain no recycled compounds except that generated in the manufacturer's own plant from resin of the same specification from the same raw material. All HDPE pipe shall be in straight lengths. (2" HDPE pipe can be in coils if contractor straighten and re-rounds pipe with a Line Tamer Machine). Manufacturer should be ISO 9001:2008 certified or have a similar quality assurance and control program.
 5. Lateral pipe shall be PVC (polyvinyl chloride) SDR-21 (200 psi) solvent weld piping. Pipe shall be manufactured from virgin rigid PVC vinyl compounds with a Cell Class of 12454 as identified in ASTM D-1784. PVC SDR-21 pipe shall be Iron Pipe Size (IPS) conforming to ASTM D-1785. Pipe shall be manufactured with solvent weld bell end joints. Pipe shall be as manufactured by Cresline Plastic Pipe, CertainTeed, JM Eagle or approved equal.
- O. Pipe Fittings:
1. Butt Fusion Fittings – Fittings shall be made from HDPE pipe resin meeting ASTM D 3350 with a minimum cell classification of 445574C. Molded butt fusion fittings shall have a manufacturing standard of ASTM D 3261. Fabricated fittings shall have the same pressure rating as the pipe; a DR less than the pipe shall be used. Fabricated fittings are shall be manufactured using a Data Logger to record temperature, fusion pressure, and a graphic representation of the fusion cycle shall be part of the Quality Control records.
 2. Electrofusion Service Saddles – Electrofusion Service Saddles shall be made from resin or pipe meeting ASTM D 3350 with a minimum cell classification of 445574C. Electrofusion Service Saddles shall meet manufacturing standard of ASTM F 1055, AWWA C906. Electrofusion saddles shall be FNPT with Ductile iron outlet.
 3. Flanged and Mechanical Joint Adapters – Flanged and Mechanical Joint Adapters shall be made from materials containing resin that meets ASTM D 3350 with a minimum cell classification of 445574C.
 4. Main line fittings and service tees 2" and larger shall be manufactured of ductile iron (DI), Grade 65-45-12 in accordance with ASTM A-536. Fittings to have deep bell push-on joints with gaskets meeting ASTM F-477. Fittings shall be HARCO DEEP BELL type, with retainer connecting licks - as required, as manufactured by The Harrington Corp. or approved equal. PVC gasketed fittings may be used, with Designer's written approval, where such fitting configurations are not manufactured in the DI type – such fittings shall be as manufactured by Scepter, Flo-Control, Inc. or approved equal. Flanged cast iron Class 125 psi or other

approved fittings may be used on large size pipe where considered necessary, i.e. to accommodate flanged valves, etc.

5. Schedule 80 PVC (polyvinyl chloride) fittings shall conform to ASTM D 2467. PVC (polyvinyl chloride) Schedule 80 threaded fittings shall conform to ASTM D 2464. All PVC (polyvinyl chloride) nipples shall be Schedule 80 with molded threads. Close nipples to not be allowed. Fittings and nipples shall be as manufactured by Spears Manufacturing or approved equal.
6. Schedule 40 PVC (polyvinyl chloride) shall conform to ASTM D 2466. Fittings shall be as manufactured by Spears Manufacturing, Lasco Fittings Inc. or approved equal.

P. Dielectric Fittings:

1. ASTM F 441/F 441M, Schedule 80, CPVC threaded pipe nipples, 4-inch length.

Q. Sprinklers:

1. Sprinklers shall be of the gear driven type with internal check valve, stainless steel riser, adjustable or fitted radius, and rubber cover.
2. Sprinklers 45'-60' radius sprinklers shall be model I-40-04-SS as manufactured by Hunter Industries or approved equal.
3. Sprinklers 25' – 45' radius shall be model I-20-04-SS as manufactured by Hunter Industries or approved equal.

R. Swing Joints:

1. Quick coupling valve swing joints shall be made of Ductile Iron per ASTM A-536. Gaskets shall meet the requirements of ASTM F-477. Swivel joints shall be as cast, permitting free rotation. Joint restraints for 1½" PVC IPS riser pipe shall have machined serrations and shall be actuated with one bolt. Swing Joints shall be model 1 ½" Male NPT x 1" Male NPT with quick coupler anchor as manufactured by The Harrington Corporation or approved equal.
2. Swing joint used for sprinklers shall be 1" 315 psi rated PVC (polyvinyl chloride) swing joint, ultra uni-body series as manufactured by Dura or approved equal.

S. Valves:

1. Lateral to mainline connection shall be made with ductile iron, resilient seated angle valve. Valve body and restraint clamps shall be constructed of ductile iron per ASTM A-536, Grade 65-45-12. Epoxy coating on all interior and exterior surfaces shall be fusion bonded epoxy, 10-12 mil thickness. Valve mechanism and hardware shall be made of 100% 316 stainless steel. The valve stem shall be fine threaded stainless steel, O-Ring sealed for ease of operation. Restraint shall have blunt cast serrations. Machined threaded restraints will not be allowed. Valve shall have a shroud around the valve stem to accept IPS PVC sleeve. All lateral to mainline transitions shall be model LV-220 as manufactured by Leemco, Inc., U.S.A. or approved equal
2. All main line valves shall HDPE fusible valves shall be model 85/PEBV/DR11 HDPE ball valves as manufactured by American AVK Company or approved equal. Supply two (2) - 5 ft. main line valve keys.
3. Quick-coupling valves shall be two-piece bronze bodies, double slot, 1" and 1½" IPS with lock top. Supply four (4) keys. Valves shall be model #44-LRC and #7 as manufactured by Rainbird. Coupler shall be model #44K-1 and 7K as manufactured by Rainbird; supply four (4) couplers. Brass hose swivels shall be 1" X 3/4" model #SH-1 as manufactured by Rainbird; supply four (4) swivels.
4. Automatic valves shall be plastic globe type, normally closed, electric solenoid-actuated and diaphragm-operated with flow stem. Solenoid shall be epoxy impregnated 24 VAC-60 Hz (18

to 30 VAC), 5.8 VA and shall be suitable for direct burial. Valves shall be capable of manual operation by means of an internal bleed. Sizes shall be as noted on the drawings. Valves shall be PEB series as manufactured by Rainbird. Valves with pressure regulation option shall be PEB-PRS-B series as manufactured by Rainbird.

5. Hydrometer (Base bid) to be two-wire ready 2" normally open with flanged fittings. Hydrometer to be model BL-BHM2300-NO as manufactured by Baseline.
6. Hydrometer (Alternate bid) to be two-wire ready 2" normally open with flanged fittings and preinstalled in Munro pump station. Hydrometer to be model BL-BHM2300-NO as manufactured by Baseline.
7. Valve identification tags shall be manufactured from polyurethane Behr Desopan, incorporating an integral attachment neck and reinforced attachment hole and will be capable of withstanding 180LBS. pull out resistance. The identification tag shall be approximately 2.25" X 2.75" in size. All lettering shall be hot stamped in black and capable of withstanding outdoor usage. The standard alpha-numeric designations shall incorporate alpha-numeric lettering 1-1/8" in height. The tag color shall be YELLOW. The marking tag will be single sided stamped with the following identification sequence A1, A2, A3 etc. to match the controller number. The marking tag shall be model ID-STD-Y1. The valve identification tags shall be manufactured by T. Christy Enterprises or approved equal.

T. Valve Boxes:

1. Valve box for main line isolation valves shall be adjustable (18"-24") telescoping screw type. Valve box shall be 5 1/4" model #111130. Valve box shall be manufactured by Maclean Highline Products.
2. Valve boxes for grounding rods shall be 7" diameter valve box. BLACK in color. Valve boxes shall be model #809 with snap down BLACK cover as manufactured by Oldcastle Enclosure Solutions.
3. Valve boxes for quick coupling valves shall be 10" diameter. Valve boxes shall be model #910 with bolt down option black T-cover as manufactured by Oldcastle Enclosure Solutions.
4. Valve boxes used with automatic valve assemblies shall be 12" x 17" x 12" deep valve boxes; black in color. Valve boxes shall be model #1419-12" with L-Bolt down option Black T-cover as manufactured by Oldcastle Enclosure Solutions.
5. Valve boxes used with air release valve assemblies shall be 15" x 21" x 12" deep valve boxes; Black in color. Valve boxes shall be model #1220-12" with L-Bolt down option BLACK T-cover as manufactured by Oldcastle Enclosure Solutions.
6. Valve box extensions, as required, shall be of the same size, color and manufacturer as the box on which it is used.

U. Rain Sensor and Conduit:

1. Rain sensor shall be Mini-Click rain sensor with stainless steel sensor guard, model 502 as manufactured by Hunter Industries.

V. Moisture Sensors/Controls:

1. Moisture sensor shall be model BL-5315B with 50' of connection wire as manufactured by Baseline.

W. Pressure Gauges:

1. Pressure gauges shall be stainless steel (0-100 PSI) 2 "diameter x 1/4" NPT, model 20-W-1005S-H-02-L-100# steel as manufactured by Ashcroft.

2.3 ACCESSORY MATERIALS

- A. Drainage Stone for Valve Boxes:
 - 1. One-half inch (1/2") to three-quarter (3/4") size, washed, graded crushed stone.
- B. Fabric:
 - 1. Soil separation fabric at valve boxes shall be Mirafi 140N, non-woven, spun bound, polyester geotextile fabric or approved equal.
- C. Warning Tape:
 - 1. Three-inch (3") 5mil Non-Detectable Blue Marking tape with the words "Caution Buried Irrigation Line Below" as manufactured by T. Christy Enterprises or approved equal.
- D. Brick:
 - 1. Common, grade SW, per ASTM C42.
- E. Reinforcing Rods:
 - 1. Steel, galvanized. #4 x 30"
- F. Bedding for Piping Material:
 - 1. Coarse, mason sand conforming to ASTM C-33.
- G. Trench Backfill in Lawn and Planting Areas:
 - 1. Conform to requirements of soil mixtures as specified in Section 329100.
 - 2. Conform to requirements of sub grade materials (Controlled Fill) as specified in Section 313000, Earthwork.
- H. Suitable excavated materials removed to accommodate the irrigation system work are shall be used as fill materials provided it conforms to the requirements of fill as noted above.
 - 1. Soils on site are to consist of sub grade materials and planting soil mix. Materials placed at different levels and thicknesses depending upon planting types and locations. Separation of materials shall be maintained.
- I. PVC Cement:
 - 1. PVC (polyvinyl chloride) cement shall be Low-VOC.
 - 2. PVC cement for Schedule 40 PVC shall be Weld-on #721 or Weld-On #725 Wet "R" Dry as manufactured by IPS Corporation.
 - 3. PVC cement for Schedule 80 pipes and nipples shall be Weld-on #711 as manufactured by IPS Corporation.
 - 4. PVC primer shall be Weld-on #P-70 (purple).

PART 3 EXECUTION

3.1 EXAMINATION

- A. Examine the areas and conditions where irrigation is to be installed. Notify the Owner's Representative, in writing, of conditions detrimental to the proper and timely completion of the Work. Do not proceed with the Work until unsatisfactory conditions have been corrected in a manner acceptable to the Owner's Representative.

3.2 PREPARATION AND STAKING

- A. The location of sprinkler heads, valves and piping, noted on the Contract Drawings, are generally diagrammatic to the extent that swing joints, off sets and all pipe fittings are not shown; exact locations of piping, sprinkler heads, valves, and other components shall be approved by the Owner's Representative in the field prior to the time of installation.
- B. Pipe routing is shall be in accordance with the Contract Drawings, however, the Owner's Representative to have the right to change the route and/or depth of the pipe from that shown in cases where rock or other obstacles may interfere with the intended path or depth of the piping.
- C. Stake all pipe and wire routes, sprinkler, valve and controller locations in accordance with the locations noted on the Contract Drawings; furnish and install staking prior to the commencement of Work in any area of installation.
- D. Notify the Owner Representative a minimum of five (5) days prior to the scheduled staking.
- E. Coordinate the irrigation work with planting and lawn work, to have irrigation available at time of the turf and plant material establishment.
- F. Coordinate irrigation work with plumbing, electrical and sleeve work.
- G. Final system layout shall be acceptable to the Owner's Representative.

3.3 CUTTING AND PATCHING

- A. Methods and materials used for cutting and patching shall be acceptable to the Architect.
- B. Materials and finishes for all patching to match existing cut surface materials and finish.
- C. Cut through concrete and masonry with core drills. Jack hammers not permitted.
- D. Seal all openings in exterior walls water-tight with link seals.

3.4 CONDUIT:

- A. Install all electrical conduits for 24V control wiring.
- B. Backfill and thoroughly compact around all conduit.
- C. All conduits to have a minimum cover of twenty-four inches (24").

3.5 SLEEVES:

- A. Coordinate and install all sleeves for all piping and conduit passing under pavement while the same are under construction.
- B. Install ends of sleeves six to twelve-inches (6"-12") beyond the edge of all pavement and curbs.
- C. Backfill and thoroughly compact around all sleeves.
- D. All sleeves to have a minimum cover of twenty-four inches (24").
- E. All sleeve locations shall be staked or permanently marked.

3.6 INSTALLATION

- A. Interior Plumbing:
 - 1. See mechanical drawings for point of connection.
- B. Winterization Assembly:
 - 1. Install winterization assemblies as detailed on the Contract Drawings.
- C. Booster Pump Package:
 - 1. The Irrigation Contractor shall be responsible for providing all materials, equipment and labor necessary to install all items associated with the packaged pump station.

2. When discharge piping, electrical connections and electrical inspection have been completed and the irrigation system can deliver 100% of the total system demand, the pump station manufacturer shall be contacted for startup. A minimum one-week notice shall be given to the manufacturer prior to start-up date. During start up the complete pumping system shall be given a running test of normal start and stop and fully loaded operating conditions. During this test the pump to demonstrate its ability to operate without undue vibration or overheating and to demonstrate without question its general fitness for service. All defects shall be corrected, and adjustments made.
 3. After the startup has been completed, but before leaving the job site, a training session will be given.
 4. The training session will be given to the Owner and the Owner's representative to familiarize them with the pumping system operation, maintenance and adjustments.
- D. Booster Pump Power Supply:
1. Booster pump power supply shall be supplied from the electrical panel provided by the Borough of Naugatuck.
 2. The Contractor shall be responsible for all wiring and associated equipment to connect power supply to the booster pump from the electrical panel.
 3. All wiring is shall be in accordance with all state and local codes.
- E. Hydrometer:
1. Hydrometer shall be pre-installed within pump station enclosure by the pump manufacturer.
- F. Main Line Isolation Valve(s):
1. Install main line Isolation valves as detailed on the Contract Drawings.
- G. Master Valve:
1. Install master valve on mainline and connect to the master valve terminal of the irrigation controller. See detail drawings.
- H. Excavating and Backfilling:
1. Provide all excavation, backfilling and compaction required for the proper installation of all piping.
 2. All piping is shall be trenched by hand or machine. Pipe pulling method is not shall be used.
 3. Minimum trench width shall be three inches (3") on each side of the main line pipe and one and one-half inches (1½") on each side of lateral pipe to allow for proper compaction of backfill material.
 4. Excavate to the depths required to allow a four-inch (4") depth of sand bedding material for piping when unsuitable bearing materials are encountered.
 5. Minimum depth of cover:
 - a. Main line piping: - twenty-four inches (24") of cover.
 - b. Lateral piping: - fourteen inches (14") of cover.
 - c. Control wire: - fourteen inches (14") of cover.
 - d. Control wire and pipe under pavement: - twenty-four inches (24") of cover.
 6. The trench bottom should be smooth and free of rocks greater than one and one-half inches (1 1/2") diameter, large dirt clods or any frozen material. Excavation at bells (bell holes) should be provided to allow pipe shall be fully supported along its length.

7. Bed pipe to provide uniform longitudinal support under the pipe to prevent low spots.
 8. Backfill material shall be free from rock, large stones, or other unsuitable substances to prevent damage to pipe during backfilling operations. Refer to section 312000 "Earthmoving".
 9. Install a four-inch (4") depth of sand bedding material where pipe settles on rock, shale or where the pipe cannot be fully supported along its entire length.
 10. Initial four inches (4") of backfill shall be properly compacted continuously above the bedding and around the pipe as well as between the pipe and undisturbed trench walls. Initial backfill is shall be done by hand.
 11. Backfill trenches to match adjacent grade elevations with approved trench backfill material. Place and compact fill in layers not greater than six-inch (6") depth to ninety-five percent (95%) maximum dry density at optimum moisture content under all paving areas and eighty five percent (85%) maximum under lawn and planting areas.
 12. Install warning tape directly above pressure piping, 12 inches (12") below finished grades, except 6 inches (6") below subgrade under pavement and slabs.
 13. Throughout the duration of the Contract refill any trenches that may have settled.
 14. Excavate trenches; install piping and backfill during the same working day. Do not leave open trenches or partially filled trenches overnight.
 15. Trenches shall be compacted and left flush with the present grade and raked clean of stone with a fine rake. This will not be necessarily construed as a final seed bed.
 16. Deleterious material shall be dug and hauled to an accessible dumping site. Contractor shall put such replacement backfill material in place at his expense.
- I. Pipe Fusion:
1. Sections of polyethylene pipe should be joined into continuous lengths on the jobsite above ground. The joining method shall be the butt fusion method and shall be performed in strict accordance with the supplier's recommendations. The butt fusion equipment used in the joining procedures should be capable of meeting all conditions recommended by the pipe supplier. The butt fusion joining will produce a joint with weld strength equal to or greater than the tensile strength of the pipe itself. All field welds shall be made with fusion equipment equipped with a Data Logger. Temperature, fusion pressure and a graphic representation of the fusion cycle shall be part of the Quality Control records.
 2. Mechanical joining will be used where the butt fusion method cannot be used. Mechanical joining will be accomplished by using a HDPE flange adapter with a ductile iron back-up ring.
 3. Hot gas fusion, threading, solvents, and epoxies will not be used to join HDPE pipe.
- J. Pipe Laying:
1. Inspect the pipe for defects before installation and fusion. Defective, damaged or unsound pipe will be rejected.
 2. Install PVC piping in dry weather when temperature is above 40 degrees Fahrenheit. Allow joints to cure at least twenty-four (24) hours at temperatures above 40 dig F before testing.
 3. Pipe shall be installed in accordance with ANSI/ASAE Standard #S376.1 and the printed instructions of the manufacturer, including leveling of trench bottoms, bedding of pipe in bottom trench and securely thrusting any fittings to change direction of gasketed pipe.
 4. Make solvent weld joints in strict accordance with ASTM D2855 and the manufacturers printed instructions. Color primer shall be used.

5. Allow joints to set at least twenty-four (24) hours before pressure is applied to the system.
 6. Maintain pipe interiors free of dirt and debris. Close open ends of pipe by acceptable methods when pipe installation is not in progress.
 7. Join HDPE pipe using butt-fusion technique as per the written instructions of the manufacturer.
Join
 8. HDPE pipe to dissimilar pipe material using HDPE (butt-fusion) x flange adapter with ductile iron back-up ring.
- K. Clearances:
1. Minimum horizontal clearances between pipes: four-inches (4") for two-inch (2") pipe and less; twelve-inches (12") for two-inch (2") pipe and more.
 2. Minimum vertical clearances between pipes: Two-inches (2").
 3. Install copper tracing wire in all pipe trenches. Terminate tracing wire at automatic valve assembly valve box.
- L. Dielectric Fittings:
1. Where pipes of dissimilar metal are joined, make connection with dielectric fitting.
 2. Provide dielectric fittings between copper and ferrous metal piping and materials in accordance with Section 220500.
- M. Sprinklers, Spray Heads, Quick Coupling Valves, Fittings, and Accessories:
1. Sprinklers and Quick Coupling Valves shall be connected to the piping system by installing factory assembled PVC swing joints. Swing joint size shall be the same size as that of the IPS inlet of the sprinkler, or as otherwise shown. The long nipple of the swing joint shall be set between 20 and 60 degrees from the horizontal. Install quick coupling valve in six-inch (6") valve box and set within one inch (1") of the bottom of the box cover.
 2. All sprinklers and quick-coupling valves shall be set flush to grade.
 3. Install fittings, valves, sprinkler heads, risers and accessories in accordance with manufacturer's printed instructions, except as otherwise indicated or as detailed on the Contract Drawings.
 4. Install all pop-up spray heads with flex pipe swing joints as shown on the drawings.
 5. Obtain Irrigation Design Consultant's review and acceptance of height for risers, spray heads, sprinklers and quick coupling valves.
- N. Valve Boxes and Valve Assemblies:
1. All valve box locations shall be staked prior to installation and approved by the Irrigation Consultant prior to starting construction.
 2. Valve boxes shall be installed as shown in the Contract Drawings with adequate space for operation, service and removal of the equipment in the box.
 3. A minimum of six-inches (6") of one half-inch ($\frac{1}{2}$ ") gravel shall be placed under, in and around each valve box for both drainage and leveling the box. Gravel installed inside valve box is not acceptable.
 4. Where necessary to properly fit the pipe, boxes shall be neatly cut to provide a firm fit to the pipe. Do not allow soil or gravel to enter the box through these cut-outs.
 5. Install filter fabric under gravel and around valve box as detailed on the Contract Drawings.
Duct tape fabric to valve box.

6. Do not group more than two (2) irrigation valve boxes together in one location. When grouping two valve boxes together allow twelve-inches (12") of space between boxes.
 7. All boxes shall be mounted plumb and flush to grade - extensions shall be used as required for proper installation and setting. Surrounding grade shall be established with the use of a leveling board not less than four feet (4') in length. Box shall be set to the underside of this board.
 8. Do not install more than two (2) valve assemblies per valve access box.
 9. Install all valve boxes in planters in a location approved by the Owner's representative. Do not install valve boxes in lawn areas.
 10. Seal threaded connections on pressure side of control valves with Teflon tape.
 11. Automatic valve assemblies shall be as per Contract Drawings using standard brass nipples, Heavy Duty brass fittings and PVC Schedule 80 nipples.
 12. Ball valves shall be installed in the "closed" position and to not be opened until the main line piping system has been pressurized and flushing has been completed through the blow-out valve assemblies.
 13. Assemble brass to brass threaded fitting connections with non-hardening thread sealant - Lasco Blue Pipe Thread Sealant, Permatex #80045, or approved equal.
 14. Assemble threaded PVC to PVC, or brass to PVC, with the use of two (2) wraps of Teflon tape.
 15. Assemble threaded connections so that thread sealant or Teflon tape does not enter the pipe or fitting.
 16. Automatic valve manual bleeds to not be used for continual operation. For extended use without 24VAC, the manual bleed shall be left in the open position and the flow to the zone controlled (on-off) by the manual ball valve.
 17. Install valve identification tag on each valve assembly as shown on the drawings.
- O. Controller:
1. Controller shall be pre-installed in the pump station enclosure by the pump manufacturer.
 2. Controller shall be connected to its individual ground to obtain 15 OHM readings, or less.
 3. Install controller in accordance with all state and local codes.
- P. Controller Power Supply:
1. Power to the controller shall be supplied from a dedicated circuit and brought to the controller location (Installed as part of work of other section(s) and contract).
 2. Controller to have one circuit with full time 120 VAC GFCI outlet and 120 VAC to the controller with on/off switch.
 3. Install lightning surge arrestor with mounting bracket on the 120 VAC power supply to the controller.
 4. The irrigation Contractor shall be responsible for all wiring and associated equipment to connect power supply from dedicated circuit to the controller.
 5. All wiring is shall be done by a licensed professional.
 6. The controller shall be grounded to the building ground by connecting the ground lug of the controller directly to the building ground using a bare #6 AWG wire as per the National Electric Code (NEC).

7. All wiring shall be in accordance with all State and local codes. Refer to and comply with Electrical work requirements specified in Division 26.

Q. 2-Wire Path:

1. Install two-wire path(s) in conduit without any damage including nicks, cuts or abrasions to the outer jacket. Conduit should be laid in the same trench adjacent to the irrigation mainline. Install wire with slack to allow for thermal expansion and contraction.
2. Seal all wire conduits with duct sealant.
3. Install two-wire path with a thirty-six (36") slack loop at each remote-control valve box to allow raising the valve bonnet to the surface without disconnecting the wires when repair is required.
4. Install an expansion curl on each wire conductor at all wire connections of all valves and splices.
5. Expansion curls shall be formed by wrapping each wire conductor six (6) turns of wire around a one-inch (1") diameter pipe, then withdrawing pipe.
6. Connect each remote-control valve to decoder and connect to two-wire path. All connections to be done using a waterproof connector.
7. Make all wire splices by baring a three-quarters inch (3/4") of copper conductor, twisting the leads together. Wire nuts shall be used over the connection. Make wire splice completely waterproof using approved connector kits in strict accordance with the manufacturer's printed instructions and local codes.

R. Sleeves

1. Sleeves to extend two (2) feet beyond pavement, road or culvert.

S. Waterproof Connectors:

1. All connectors shall be installed per manufacturer's written specifications.
2. Verify that no loose, unshielded wiring shall touch the ground, water, or other copper conductor causing a leakage of current to the ground or a short circuit across wires.
3. Score the outer jacket of the wire 12 inches from each end without scoring conductor insulation.
4. The installer shall strip 1 inch (2.54 cm) of insulation from conductor without scoring the conductor.
5. Install an expansion curl on each wire conductor at all wire connections of all valves and splices.
6. Expansion curls shall be formed by wrapping each wire conductor six (6) turns of wire around a one-inch (1") diameter pipe, then withdrawing pipe.
7. Installer shall bundle like conductors, twist them together, and trim off 1/2 inch of conductors.
8. Installer shall twist a wire connector in a clockwise direction, and then place a moisture-proof DBR/Y-6 tube over the top making sure connector is fully seated at the top of the tube. Snap the cover completely closed.
9. Installer shall ensure that all connections are mounted in a vertical orientation to eliminate standing water inside the connector.
10. All splices shall be made inside a valve box.

T. Valve Decoders:

1. The valve decoder shall be connected to each automatic valve and two-wire path in accordance with manufacturer's printed instructions.
2. The valve decoders shall be attached to the valve wire and 2-wire path using waterproof connector.
3. The valve decoders shall not share valve wires or common wires between valve decoders.
4. The maximum wire run between the valve decoder and the solenoid shall be 150 feet (150').
5. The contractor is shall be responsible for accurately recording on the as-built drawings, as each decoder is being installed, the address number of the decoder at that location. It is also necessary that it be indicated which remote controls valves controlled by each specified decoder.

U. Sensor Decoder:

1. Install sensor decoder on flow sensor and connect to the 2-wire path in accordance with manufacturer's printed instructions.

V. Grounding/Surge Protection:

1. All surge protection and grounding shall be installed in strict compliance with the manufacturer's printed instructions and in accordance with local, State and Federal codes and requirements.
2. The ground grid components shall be installed with the dimensional relationships shown on the details.
3. Wires, cables, and electronic equipment shall be installed outside "The sphere of Influence" of the grounding electrodes.
4. Install grounding as detailed.
5. Drive the ground rod vertically to its entire length.
6. The ground plates shall be installed to a minimum depth of thirty inches (30"), or below the frost line if it is lower than 30".
7. Two 50-pound bags of "Earth Contact Material" shall be spread so that it surrounds and the copper plate evenly along its length within a six inch (6") wide trench. Use one bag only for the installation of 3-foot ground plates. Salts, fertilizers, bentonite clay, cement, coke, carbon, and other chemicals are not to be used to improve soil conductivity because these materials are corrosive and will cause the copper electrodes to erode and become less effective with time. It is important that the Earth Contact material completely surrounds the ground plate and 6" (152 mm) of the insulation of the green wire, as shown in the detail, to minimize corrosion.
8. Connect 6/1 AWG earth grounding, green insulated, solid bare copper wire to the ground rod and grounding plate with Cadweld connector. Install all grounding circuit components in straight lines and simple geometry. No sharp bends or turns shall be allowed. When necessary to bend wires, make sweeping turns as detailed. All grounding and bonding wires of electronic equipment shall be fed through a dedicated one and one-half inch (1 1/2") plastic sweep ell. "Sweep bends" shall follow the guidelines shown here. The 6/1 AWG bare copper wires shall be installed in as straight a line as possible, and if it is necessary to make a turn or a bend it shall be done in a sweeping curve with a minimum radius of eight inches (8") and a minimum included angle of 90°. This type of installation, which utilizes a multi-position bus bar, allows for rapid connecting and disconnecting of desired wires to periodically take earth resistance readings of the individual grounding electrodes.

9. The earth-to-ground resistance shall be measured at the time of installation using a “Megger”, or other similar instrument, and the reading shall be no more than 10 Ohms. If the resistance is more than 10 ohms, additional ground plates and “Earth Contact Material” shall be installed using the 100-2002 (www.asic.org, “Design Guides”.) It is required that the soil surrounding copper electrodes, within the Sphere of Influence, be kept at a minimum moisture level of 15% (by weight) always as dry soil does not conduct electricity. ALL GROUNDING COMPONENTS SHALL BE CONNECTED TO THE EQUIPMENT BEFORE ANY OTHER CONNECTION IS MADE.
10. Surge suppression device shall be installed at every 500’ of wire cable, located at the nearest line decoder and every line termination point. Install first surge suppression device within 100 feet of central control system. The surge suppression device ground wires shall be connected to a single grounding rod as detailed.
11. Measurement and Testing of Resistance
12. Earth resistance shall be measured and recorded after the installation of the grounding rods, and every three months thereafter for the first year. This data should be used to determine the most critical times of the year, based on soil moisture content and lightning frequency. The resistance shall be tested and recorded every six months thereafter, at these most critical dates, to ensure that proper contact with the soil is maintained always. Resistance measurement shall be made using commercially available instruments, in accordance with the latest requirements of NFPA 780. Follow instrument manufacturer’s specific operating instructions.
13. Readings of 5 to 10 ohms are desirable. The effectiveness of the circuit is a function of its impedance, which cannot be measured in the field in a practical manner. Sound practices and proper installation are more important in assuring quality results than this reading.
14. The minimum requirements of the NEC shall be met, which are: A resistance reading of no more than 25 ohms, or a two-electrode ground grid
15. In installations with multiple equipment locations, the resistance readings of like grounding circuits should be compared for consistency. Large variances in readings point to different soil conditions, or soils with varying degrees of moisture content, or improper installation.
16. Record OHM (resistance) readings, date and location of all grounding locations on “Construction Record Drawings”.

W. Rain Sensor:

1. Furnish and install conduit where ever wire is exposed.
2. Install rain sensor in a location approved by the Architect. Install all wire inside rigid metallic conduit.
3. Conduit shall not be attached to the outer face of any building wall without the approval of the Architect.

X. Moisture Sensors:

1. Install moisture sensors in a location approved by the Irrigation Consultant.
2. The maximum wire run between soil moisture sensor and the controller shall be the same as stated in the two-wire specifications.
3. The soil moisture sensor shall be connected to the two-wire path.
4. The soil moisture sensor shall be buried in an area of average water distribution between two sprinkler heads and placed off the centerline that the sprinklers create.

5. The soil moisture sensor shall be installed in a location representative of the zones that the sensor is controlling.
6. The soil moisture sensor shall be installed two – three inches (2"-3") below the plant or in the top 1/3 of the root zone.
7. The soil moisture sensor shall be buried with no air pockets around the sensor.
8. The soil moisture sensor shall be marked to avoid damage during aeration.
9. All splices shall be made inside the valve box with a direct burial waterproof connection.

3.7 PRESSURE TESTING

- A. Use Hydrostatic pressure test only. Pressure test using air or compressed gas is not acceptable.
- B. Testing should be performed at the lowest elevation along the pipe shall be tested.
- C. Pressure testing shall be conducted in accordance with the ASTM F 2164, field Leak testing of Polyethylene Pressure Piping Systems Using Hydrostatic Pressure. The HDPE pipe shall be filled with water, raised to test pressure and allowed to stabilize. The test pressure shall be 1.5 times the operating pressure at the lowest point in the system. In accordance with section 9.8, the pipe shall pass if the final pressure is with 5% of the test pressure for 1 hour. For safety reasons, hydrostatic testing only will be used.
- D. The test procedures consist of two steps; the initial expansion and the test phase. When test pressure is applied to a water filled pipe, the pipe expands. During the initial expansion of the pipe under test, enough make-up water must be added to the system at hourly intervals for 3 hours to maintain the test pressure. After 4 hours, initial expansion should be complete, and the actual test can start.
- E. When the test is to begin, the pipe is full of water and is subjected to a constant test pressure of 1.5 times the system design pressure. Drop the pressure by ten (10) psi. If the pressure then remains within five percent (5%) of the target value for one (1) hour, this indicates there is no leakage in the system.
- F. Solvent weld piping - Cap all risers, bleed air from pipes and perform pressure test upon completion of the main line pipe installation. All main line piping shall be tested at 150 PSI for four (4) hours. During this time, a visual inspection will be made by the Owner's Representative for leaks.
- G. When main line pipe is installed in phases and/or segments pressure test each main line segment and/or phase. Pressure test should be performed on sections not longer than 2,500 feet.
- H. All leaks shall be repaired by removing the section of pipe at the joint and installing a new section using coupling, mechanical joint or union. After repair the piping shall be retested until approved by the Owner's Representative.
- I. All lateral piping shall be tested under working conditions and visual inspection made for leaks.
- J. Notify the Irrigation Design Consultant and Owner's Representative seventy-two (72) hours prior to testing.

3.8 FLUSHING AND ADJUSTMENT

- A. After piping is installed and before sprinklers and spray heads are installed, open control valves and flush out the system with full head of water until pipe is free of all foreign materials.
- B. Adjustment of the sprinkler equipment will be done upon completion of the installation, to provide optimum performance and to assure that all sprinklers are properly set to grade.
- C. Adjust all automatic valves by means of the flow control stem and verify sprinkler discharge pressure on each lateral zone, with a pitot tube and gauge, to obtain optimum sprinkler performance in accordance with manufacturer's printed instructions.

- D. After the irrigation system, has been installed, test the entire system and demonstrate that the entire system meets coverage requirements and automatic controls function properly.

3.9 FINAL REVIEW AND ACCEPTANCE

- A. When all irrigation work is completed and the "Construction Record Drawing" has been submitted a final review of the irrigation system will be made by the Owner's Representative, upon written notice requesting such a review. Submit the written notice at least ten (10) days prior to the anticipated review.
- B. The Contractor shall have sufficient personnel and either remote control radio, cell phone or other two-way communication device to properly perform final review.
- C. Upon final review and acceptance, the Owner's Representative will notify the Owner, in writing, as to final acceptance of the irrigation system. Date of the final acceptance by the Owner is the date beginning the Warranty period.
- D. Any irrigation equipment item required under this Contract that is malfunctioning or in need of repair shall be removed and replaced. All replacements shall be of equipment and/or material originally specified.
- E. The cost of replacement shall be borne by the Entity performing Work of this Section.
- F. Upon acceptance of the entire irrigation system, instruct the Owner's designated personnel in the complete operation of the entire irrigation system.

3.10 CLEAN UP AND PROTECTION

- A. Upon completion of all work of this Section, remove and legally dispose of all excess materials resulting from the work operations of this Section.
- B. Accumulation of materials for disposal is not permitted. Disposal shall be made as fast as materials accumulate.
- C. Adequately protect all paving, surfacing, lawn areas and plant material and restore to original condition all damages resulting from work operations of this Section.

END OF SECTION 328400

SECTION I

Contract Drawings

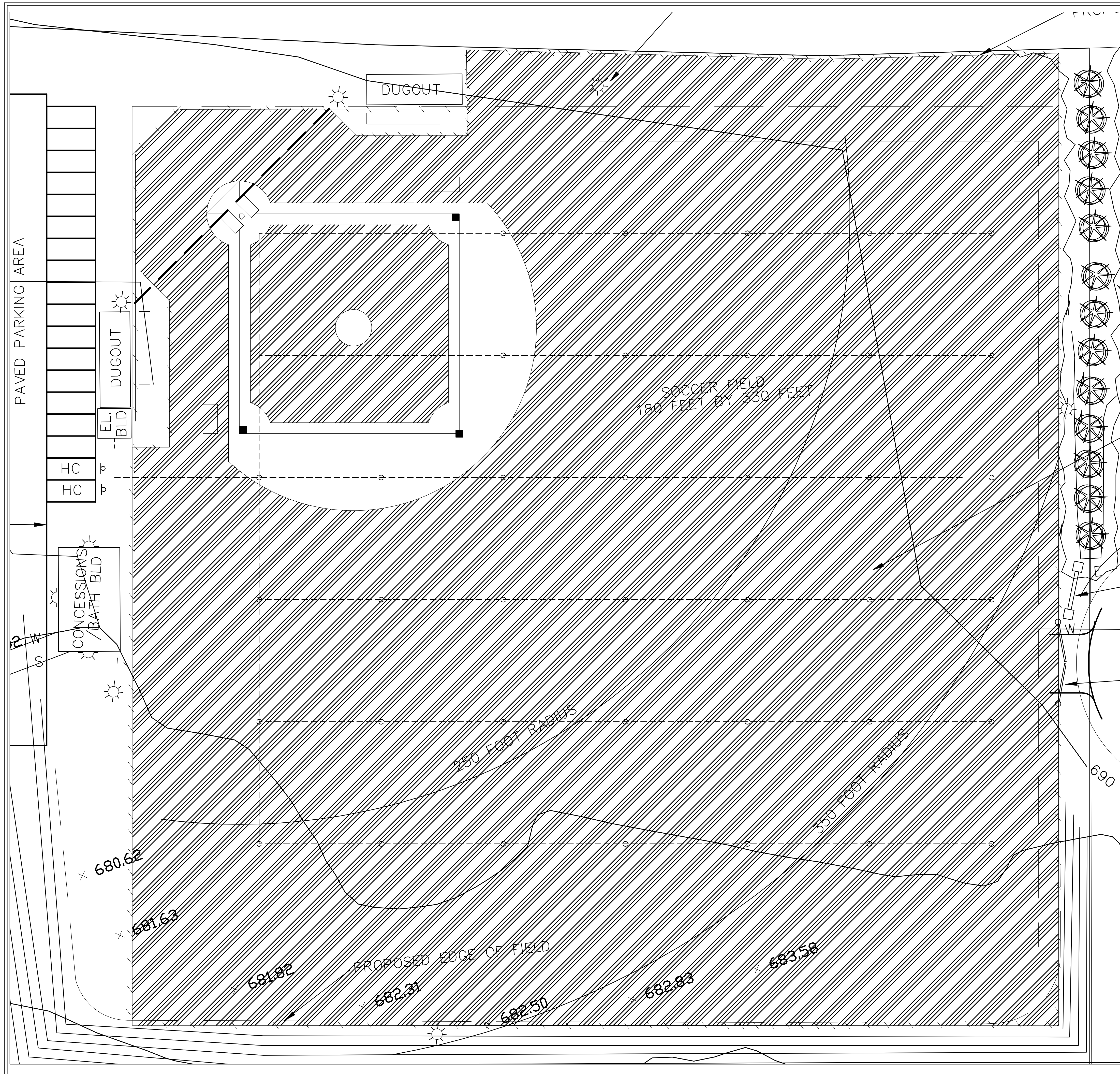

IRRIGATED AREA

SYMBOL	DESCRIPTION	2019-05-01 16:03 QTY
	TURF ROTOR 40'-65" (12.2M-20M) SQUARE SPACING SQUARE SPACED, HEAD TO HEAD COVERAGE, THE PRECIPITATION RATE INDICATED ACCOUNTS FOR FULL AND PART CIRCLE HEADS, AND IS (1.35) X (360 PRECIP RATE).	137,664 S.F.

CRITICAL ANALYSIS

Generated: 2019-04-30 23:12

P.O.C. NUMBER: 01
Water Source Information:

FLOW AVAILABLE
Point of Connection Size: 3"
Flow Available: 181.61 gpm

PRESSURE AVAILABLE
Static Pressure at POC: 40.00 psi
Booster Pump pressure provided: 40.00 psi
Pressure Available: 80.00 psi

DESIGN ANALYSIS
Maximum Multi-valve Flow: 100.00 gpm
Flow Available at POC: 181.61 gpm
Residual Flow Available: 81.61 gpm

Pressure Req. at Critical Station: 53.60 psi
Loss for Fittings: 0.87 psi
Loss for Main Line: 8.66 psi
Loss for POC to Valve Elevation: 0.00 psi
Loss for Backflow: 12.30 psi
Critical Station Pressure at POC: 75.43 psi
Pressure Available: 80.00 psi
Residual Pressure Available: 4.57 psi

WATERING SCHEDULE

NUMBER	MODEL	TYPE	PRECIP	IN/WEEK	MIN/WEEK	GAL/WEEK	GAL/DAY	
A1	HUNTER ICV-G	TURF ROTOR	1.01 in/h	1.50	90	3,726	532.3	
A2	HUNTER ICV-G	TURF ROTOR	1.12 in/h	1.50	81	4,034	576.3	
A3	HUNTER ICV-G	TURF ROTOR	0.49 in/h	1.50	183	7,576	1,082	
A4	HUNTER ICV-G	TURF ROTOR	0.50 in/h	1.50	181	7,493	1,070	
A5	HUNTER ICV-G	TURF ROTOR	0.50 in/h	1.50	180	7,452	1,065	
A6	HUNTER ICV-G	TURF ROTOR	1.17 in/h	1.50	77	3,835	547.8	
A7	HUNTER ICV-G	TURF ROTOR	0.66 in/h	1.50	137	2,740	391.4	
A8	HUNTER ICV-G	TURF ROTOR	0.96 in/h	1.50	94	2,594	370.6	
A9	HUNTER ICV-G	TURF ROTOR	0.47 in/h	1.50	192	3,264	466.3	
A10	HUNTER ICV-G	TURF ROTOR	0.59 in/h	1.50	154	1,540	220	
A11	HUNTER ICV-G	TURF ROTOR	0.41 in/h	1.50	218	3,924	560.6	
A12	HUNTER ICV-G	TURF ROTOR	0.76 in/h	1.50	119	4,927	703.8	
A13	HUNTER ICV-G	TURF ROTOR	1.32 in/h	1.50	69	2,484	354.9	
A14	HUNTER ICV-G	TURF ROTOR	0.44 in/h	1.50	205	8,487	1,212	
A15	HUNTER ICV-G	TURF ROTOR	0.46 in/h	1.50	197	8,156	1,165	
A16	HUNTER ICV-G	TURF ROTOR	1.17 in/h	1.50	78	3,884	554.9	
A17	HUNTER ICV-G	TURF ROTOR	0.50 in/h	1.50	182	10,046	1,435	
A18	HUNTER ICV-G	TURF ROTOR	0.96 in/h	1.50	94	5,189	741.3	
A19	HUNTER ICV-G	TURF ROTOR	0.50 in/h	1.50	181	9,391	1,427	
A20	HUNTER ICV-G	TURF ROTOR	0.50 in/h	1.50	182	10,046	1,435	
A21	HUNTER ICV-G	TURF ROTOR	0.49 in/h	1.50	184	10,157	1,451	
A22	HUNTER ICV-G	TURF ROTOR	1.14 in/h	1.50	79	3,934	562.0	
TOTALS:						3,157	125,480	17,926

RUNTIME SUMMARY (.25" of Water)

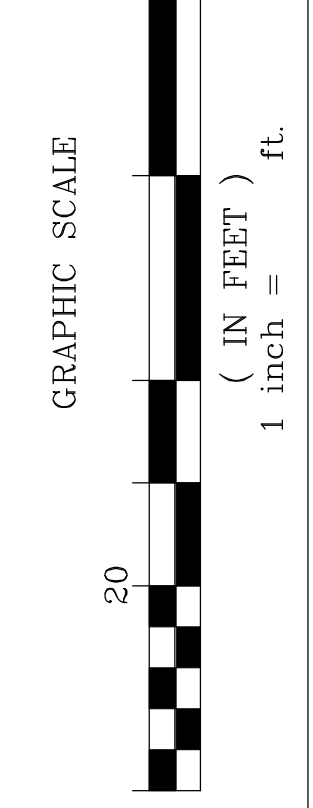
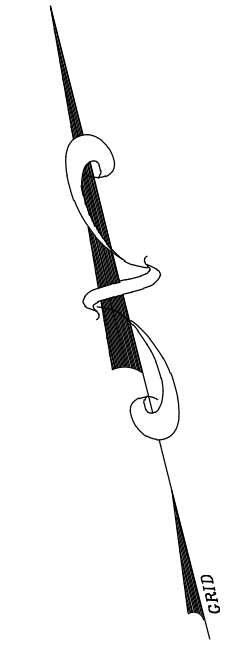
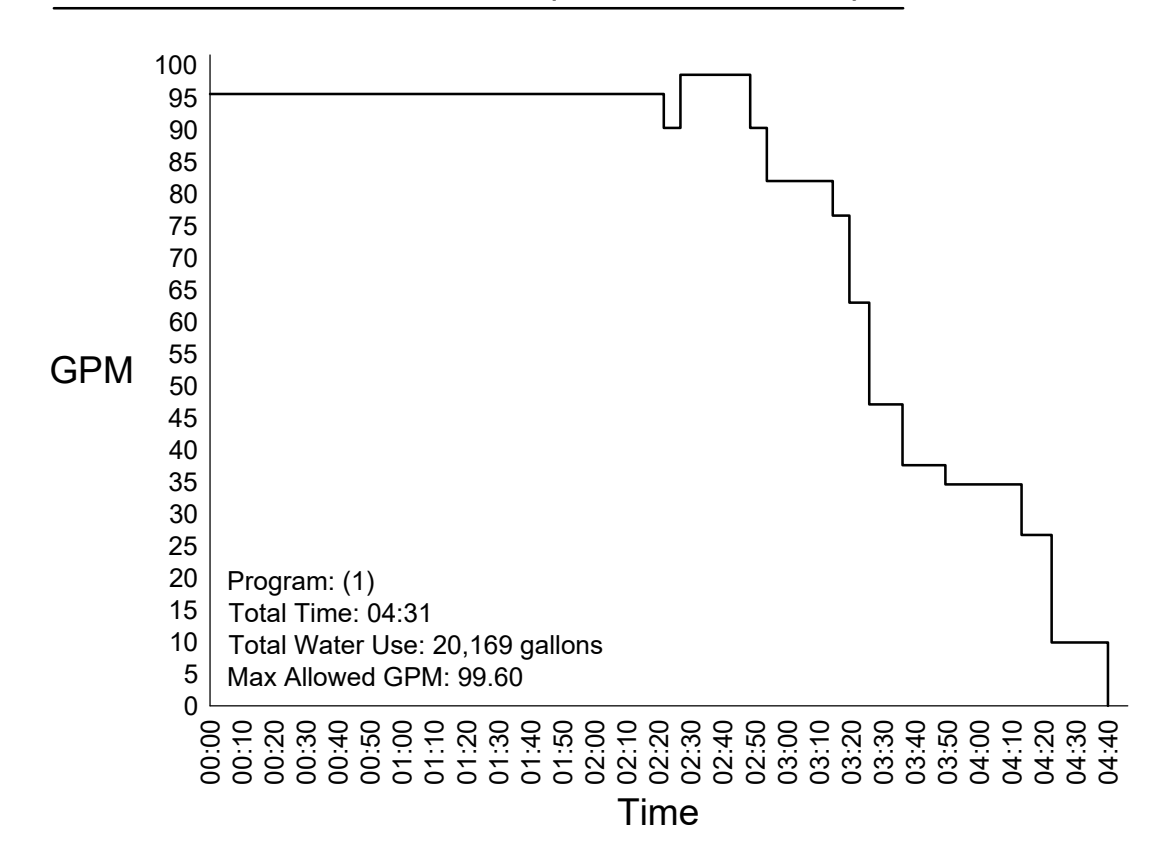

IRRIGATION PLAN
Kevin M. DeGobbo Memorial Field
ENGINEERING DEPARTMENT
BOROUGH OF NAUGATUCK
PROPOSED ATHLETIC FIELD AND PARKING
APPLE HILL ESTATES SUBDIVISION - SECTION 2
November 14, 2018
SHEET IR-1 OF 6

To my knowledge and belief, this map is substantially correct as noted hereon.

Wayne J. Zirolli, L.S. No. 13297

N/F
MORGAN DEV. CORP.
NORTHERN DESIGNS LLC
IRRIGATION CONSULTANTS AND DESIGNERS
2089 HARTFORD TURNPIKE
NORTH HAVEN, CONNECTICUT 06473
(203) 238-2710 FAX (203) 239-2715

NO.	DATE	DESCRIPTION	BY
1.	01-07-19	Diamond size & light locations	WJZ
2.	01-14-19	ADJUST DIAMOND FOR FENCE	WJZ

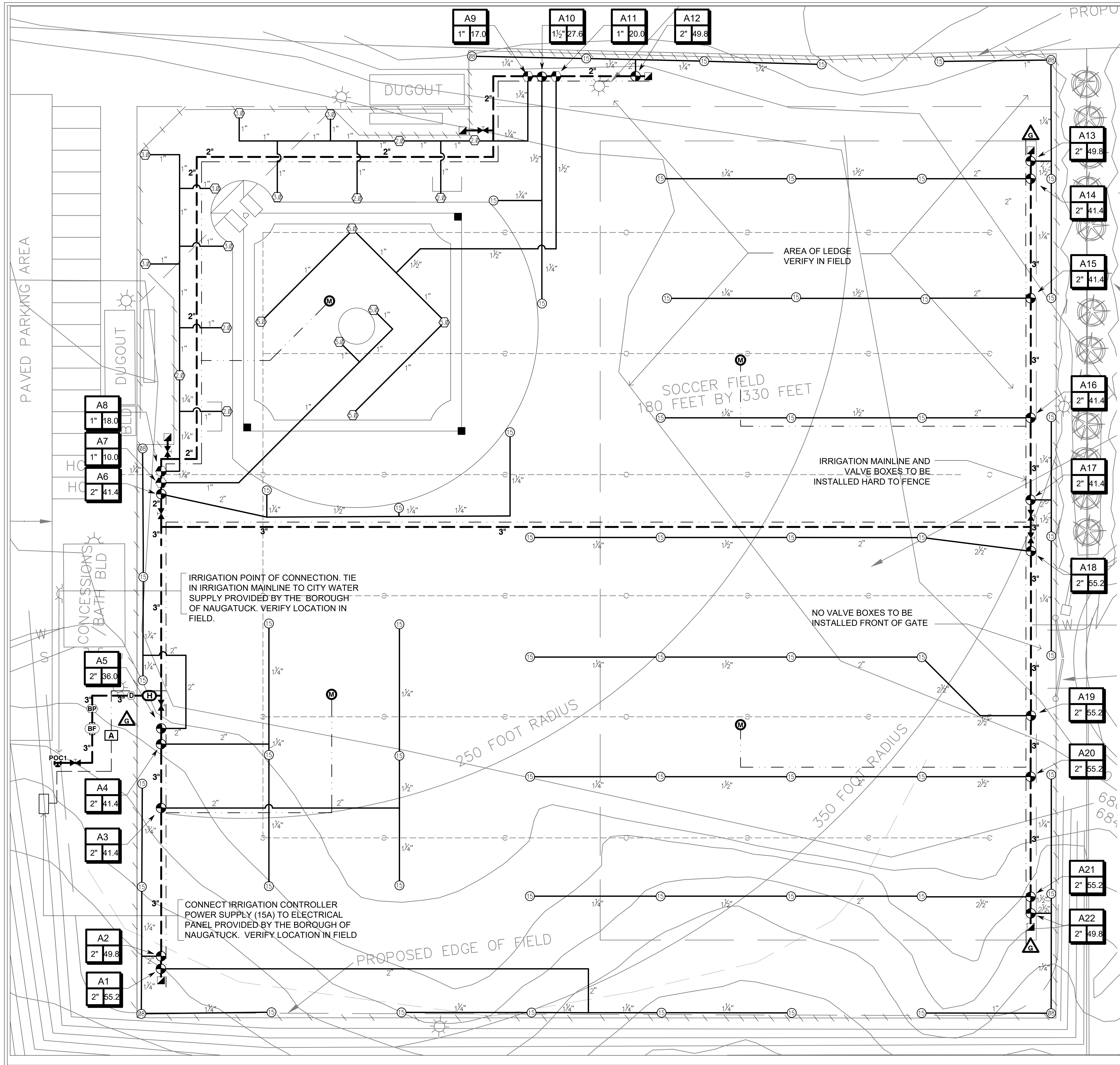

IRRIGATION NOTES:

- IRRIGATION PLAN IS DIAGRAMMATIC. ALL IRRIGATION EQUIPMENT SHALL BE LOCATED IN THE FIELD BY THE IRRIGATION INSTALLER.
- IRRIGATION INSTALLER SHALL LAYOUT AND STAKE ALL IRRIGATION EQUIPMENT IN THE FIELD PRIOR TO INSTALLATION. LOCATIONS WILL BE APPROVED BY THE LANDSCAPE ARCHITECT PRIOR TO INSTALLATION.
- ALL VALVE BOXES ARE TO BE INSTALLED HARD TO FENCE.
- THE IRRIGATION CONTRACTOR SHALL BE RESPONSIBLE FOR COORDINATING WITH OTHER TRADES.
- IRRIGATION SYSTEM REQUIREMENTS:
100 GPM @ 80 PSI
- IRRIGATION PIPING DEPTH REQUIREMENTS:
MAIN LINE PIPE - 18" OF COVER
CONDUIT FOR CONTROL WIRE - 18" OF COVER
LATERAL LINE PIPE - 12" OF COVER
- INSTALL RAIN SENSOR IN LOCATION APPROVED BY THE ARCHITECT.
- CONTRACTOR IS TO PROGRAM AND MAINTAIN CONTROLLER UNTIL FINAL ACCEPTANCE OF THE PROJECT. COORDINATE GROW-IN IRRIGATION SCHEDULE WITH LANDSCAPE CONTRACTOR.

IRRIGATION LEGEND:

Symbol	Model	PSI	GPM	Radius
⊙	HUNTER I-20-04-SS	45	2.00	34'
⊙	HUNTER I-20-04-SS	45	3.00	38'
⊙	HUNTER I-20-04-SS	45	5.00	42'
⊙	HUNTER I-40-04-SS	60	8.40	45'
⊙	HUNTER I-40-04-SS	60	13.8	54'
⊙	Pressure Reducing Automatic Valve Assembly			
⊙	Automatic Valve Assembly			
⊙	Quick Coupling Valve			
⊙	HDPE Isolation Valve			
⊙	Winterization Assembly			
⊙	Backflow Preventer (RPZ)			
⊙	Irrigation Controller			
⊙	Soil Moisture Sensor			
⊙	Ground Rod			
⊙	Hydrometer Assembly			
⊙	VFD Booster Pump Station			
⊙	Point of Connection (Verify Location in Field)			
---	Irrigation Lateral Line: PVC Class 200 SDR 21			
---	Irrigation Mainline: HDPE PE4710 DR 11			

N/F
MORGAN DEV. CORP.
NORTHERN DESIGNS LLC
IRRIGATION CONSULTANTS AND DESIGNERS
2089 HARTFORD TURNPIKE
NORTH HAVEN, CONNECTICUT 06473
(203) 239-2710 FAX (203) 239-2715

IRRIGATION PLAN
Kevin M. DeGobbo Memorial Field
ENGINEERING DEPARTMENT
BOROUGH OF NAUGATUCK
PROPOSED ATHLETIC FIELD AND PARKING
APPLE HILL ESTATES SUBDIVISION - SECTION 2
November 14, 2018
SHEET IR-2 OF 5

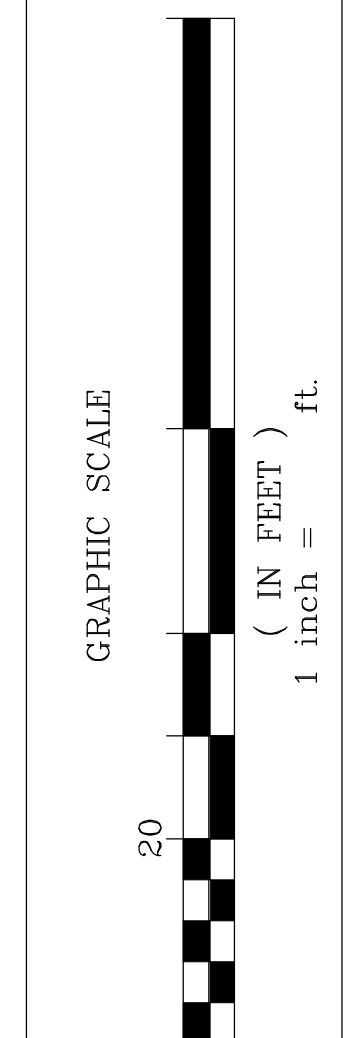

To my knowledge and belief, this map is substantially correct as noted hereon.

Wayne J. Zirolli, L.S. No. 13297

NO.	DATE	DESCRIPTION	BY
1.	01-07-19	Diamond size & light locations	WJZ
2.	01-14-19	ADJUST DIAMOND FOR FENCE	WJZ

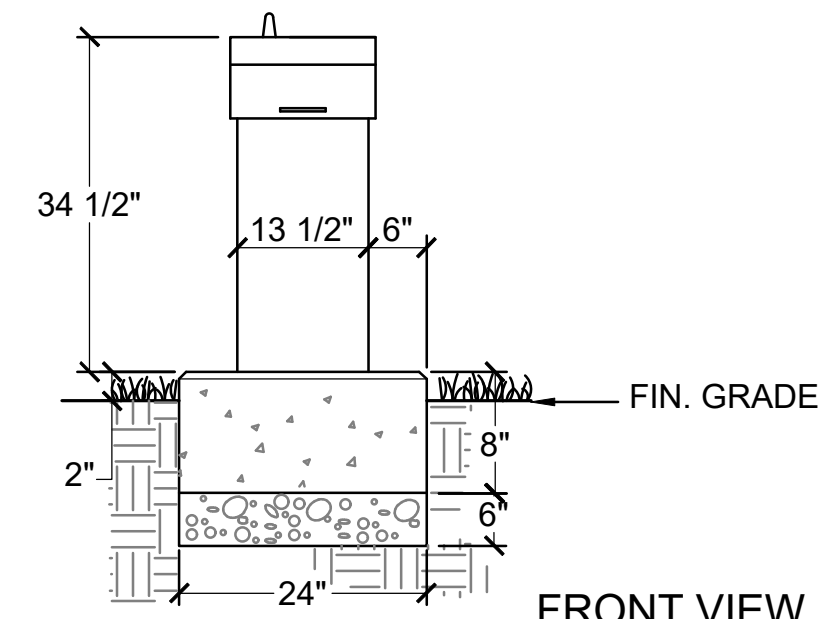

FRONT VIEW

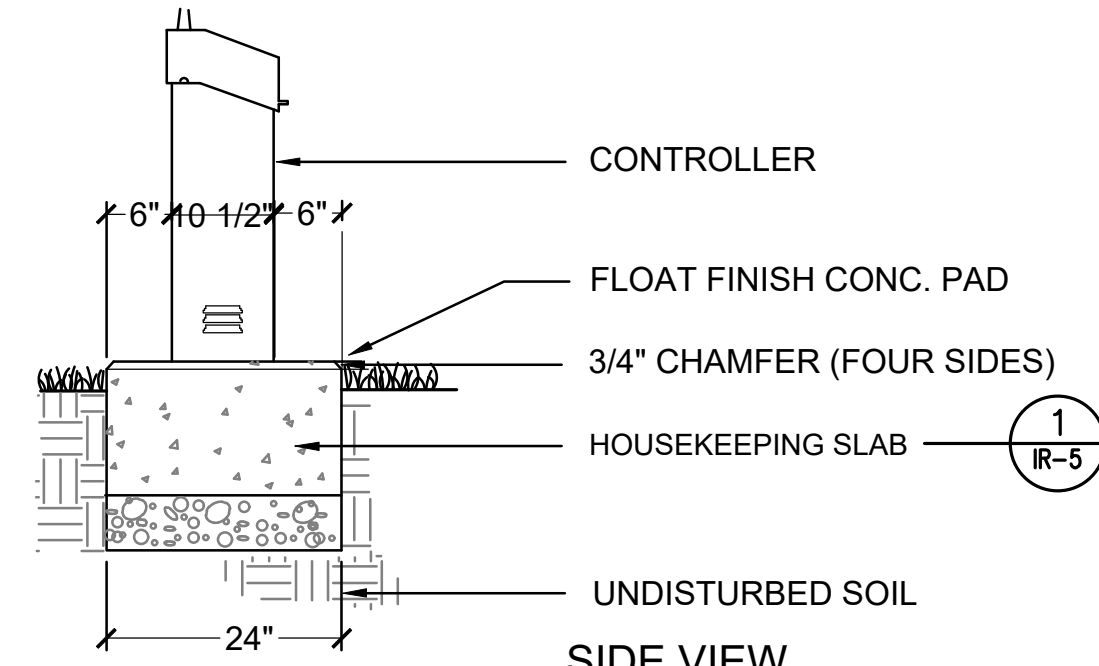

SIDE VIEW

6 PEDESTAL MOUNTED IRRIGATION CONTROLLER - BASE BID
NOT TO SCALE

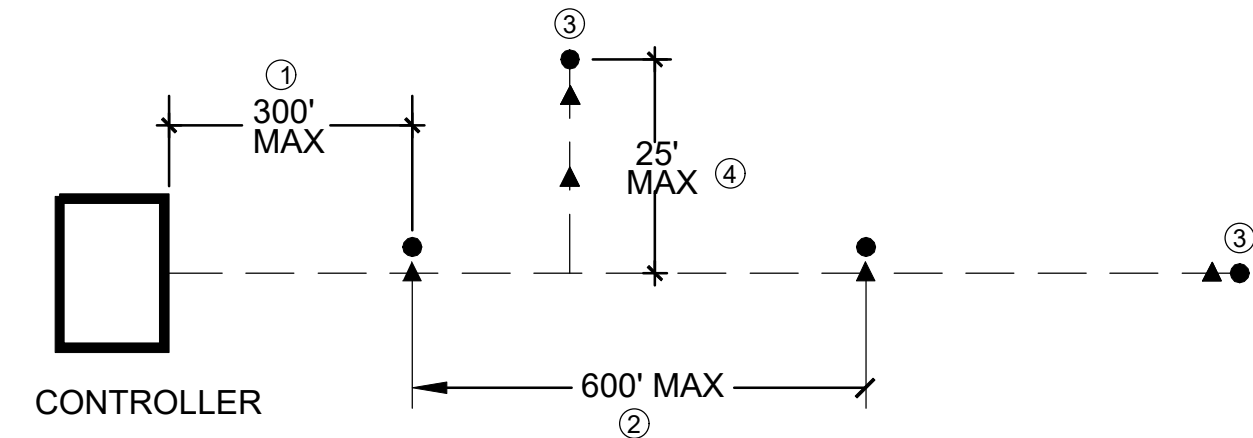

- ▲ SURGE PROTECTOR
- DECODER
- - - 2-WIRE PATH

- 1 INSTALL FIRST SURGE PROTECTOR 300' MAX FROM CONTROLLER ALONG EACH TWO WIRE PATH
- 2 INSTALL ADDITIONAL SURGE PROTECTORS 600' MAX ALONG TWO WIRE PATH
- 3 INSTALL A SURGE PROTECTOR AT END OF EACH TWO WIRE RUN
- 4 IF LATERAL BRANCH IS LESS THAN 25' A SURGE PROTECTOR IS NOT REQUIRED.

7 TWO-WIRE SURGE PROTECTION LOCATIONS - TYPICAL
NOT TO SCALE

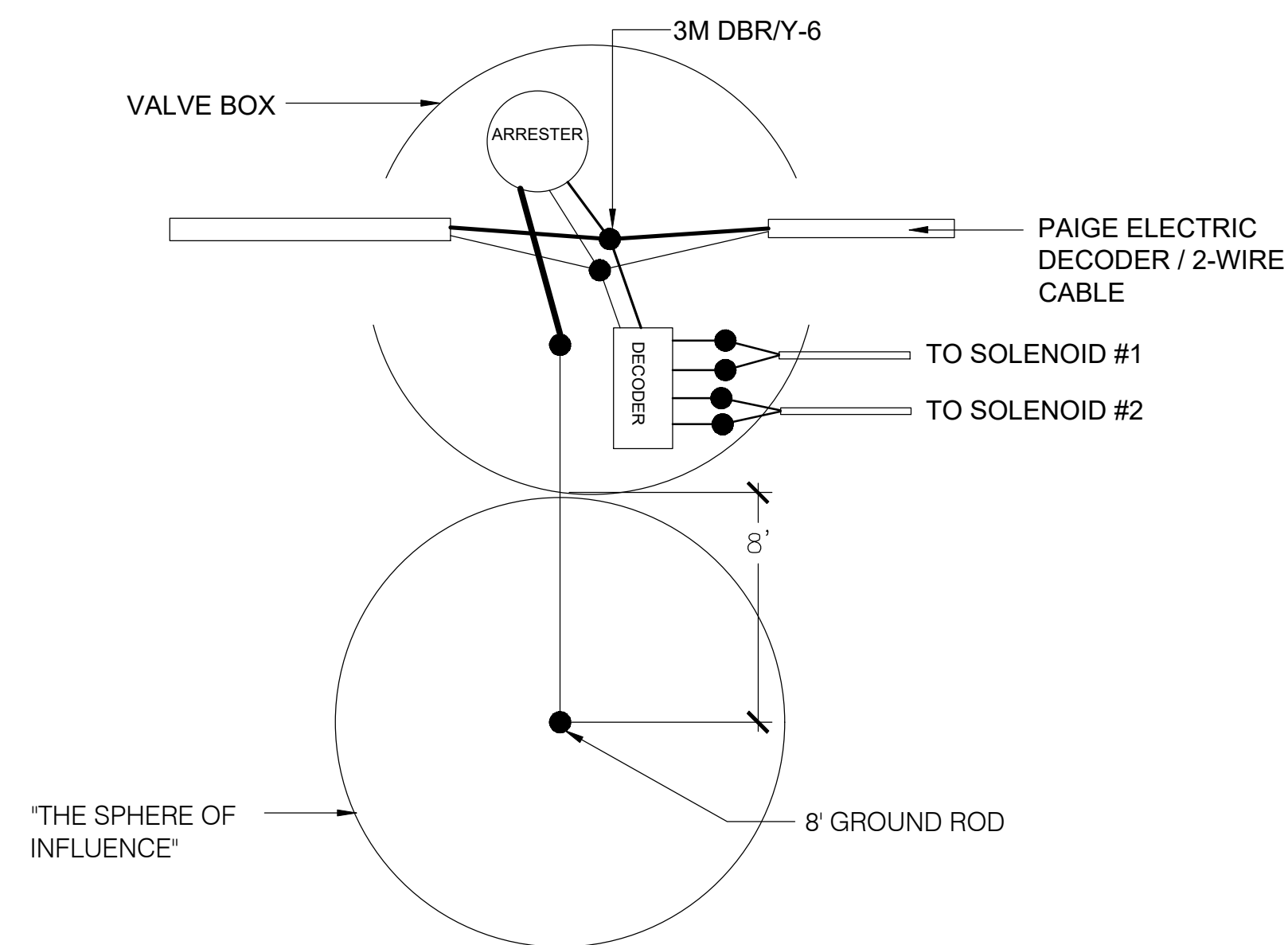

8 DECODER PROTECTED BY SURGE ARRESTOR
NOT TO SCALE

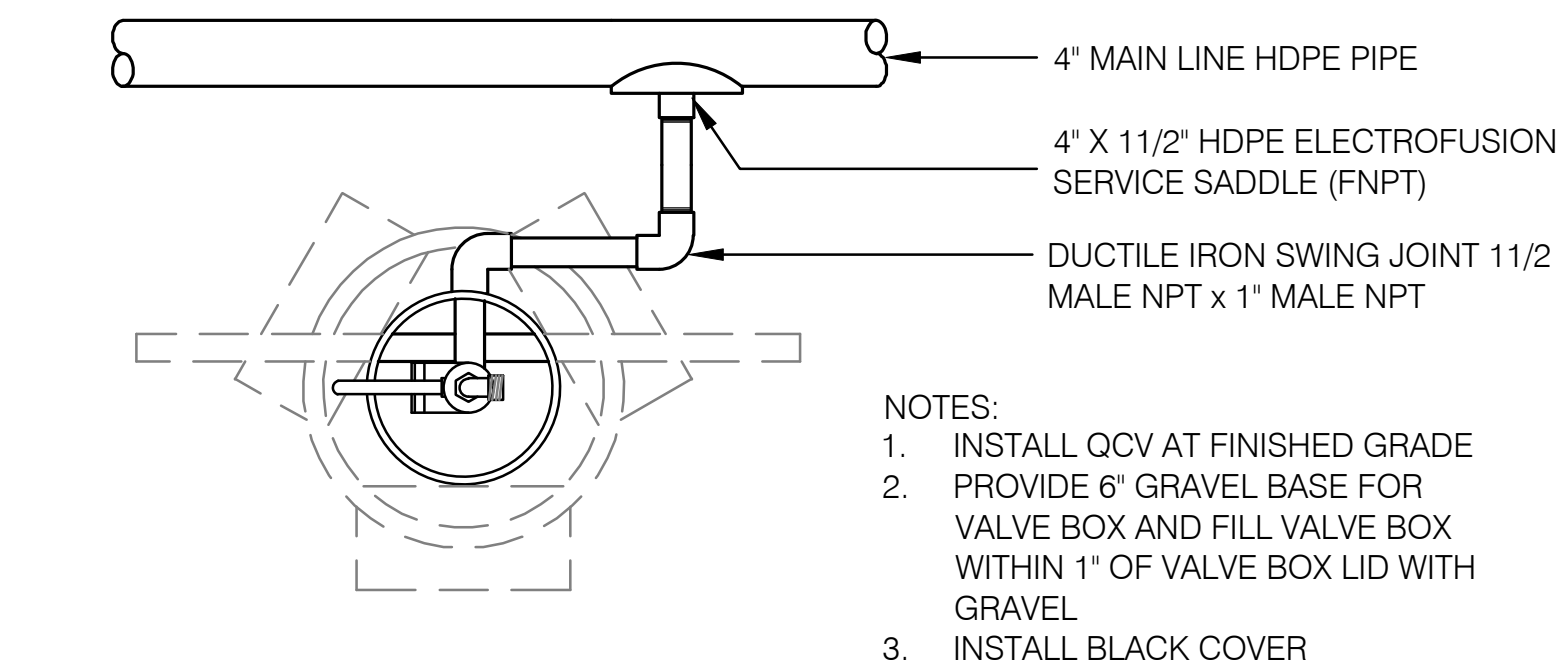

- NOTES:
1. INSTALL QCV AT FINISHED GRADE
 2. PROVIDE 6" GRAVEL BASE FOR VALVE BOX AND FILL VALVE BOX WITHIN 1" OF VALVE BOX LID WITH GRAVEL
 3. INSTALL BLACK COVER

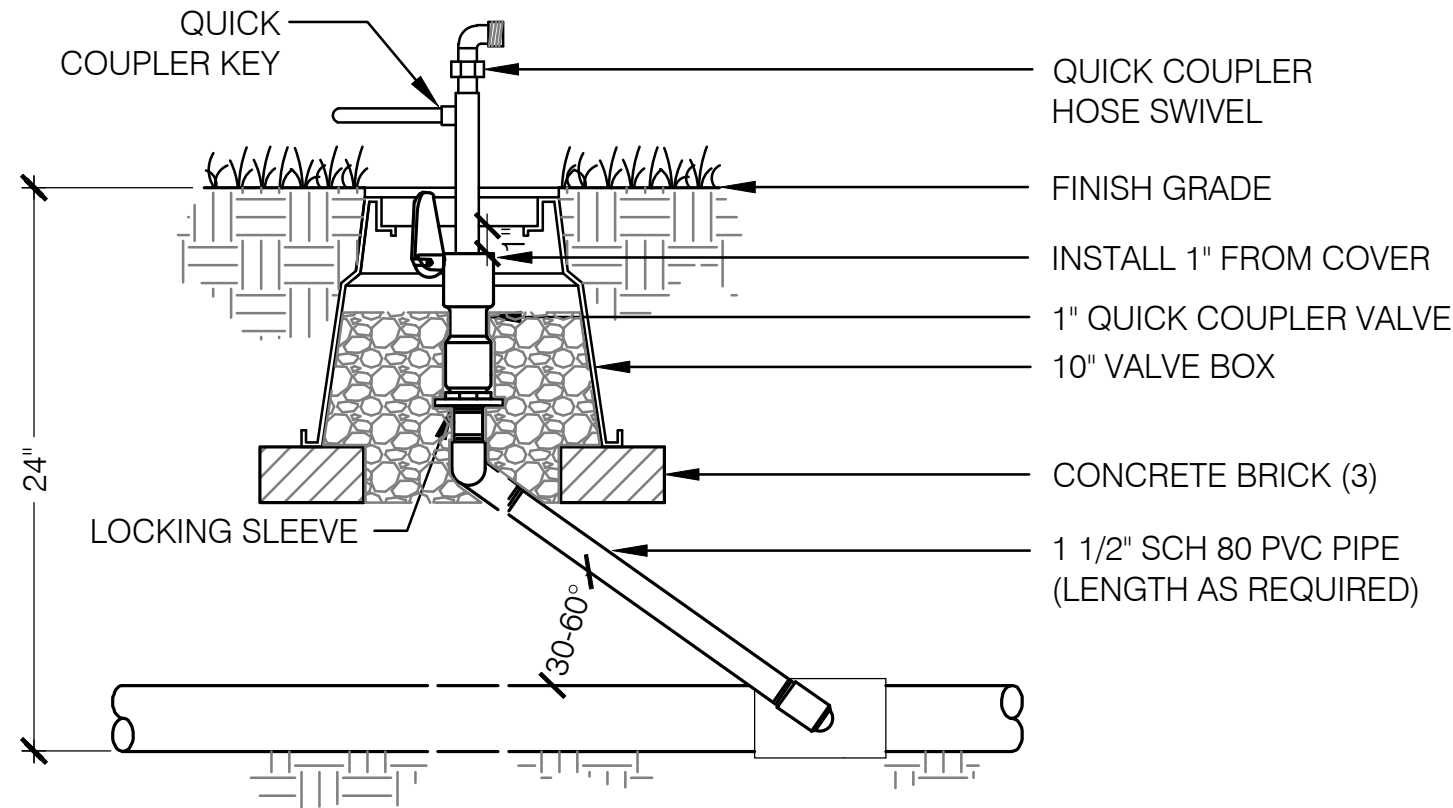

4 QUICK COUPLING VALVE
NOT TO SCALE

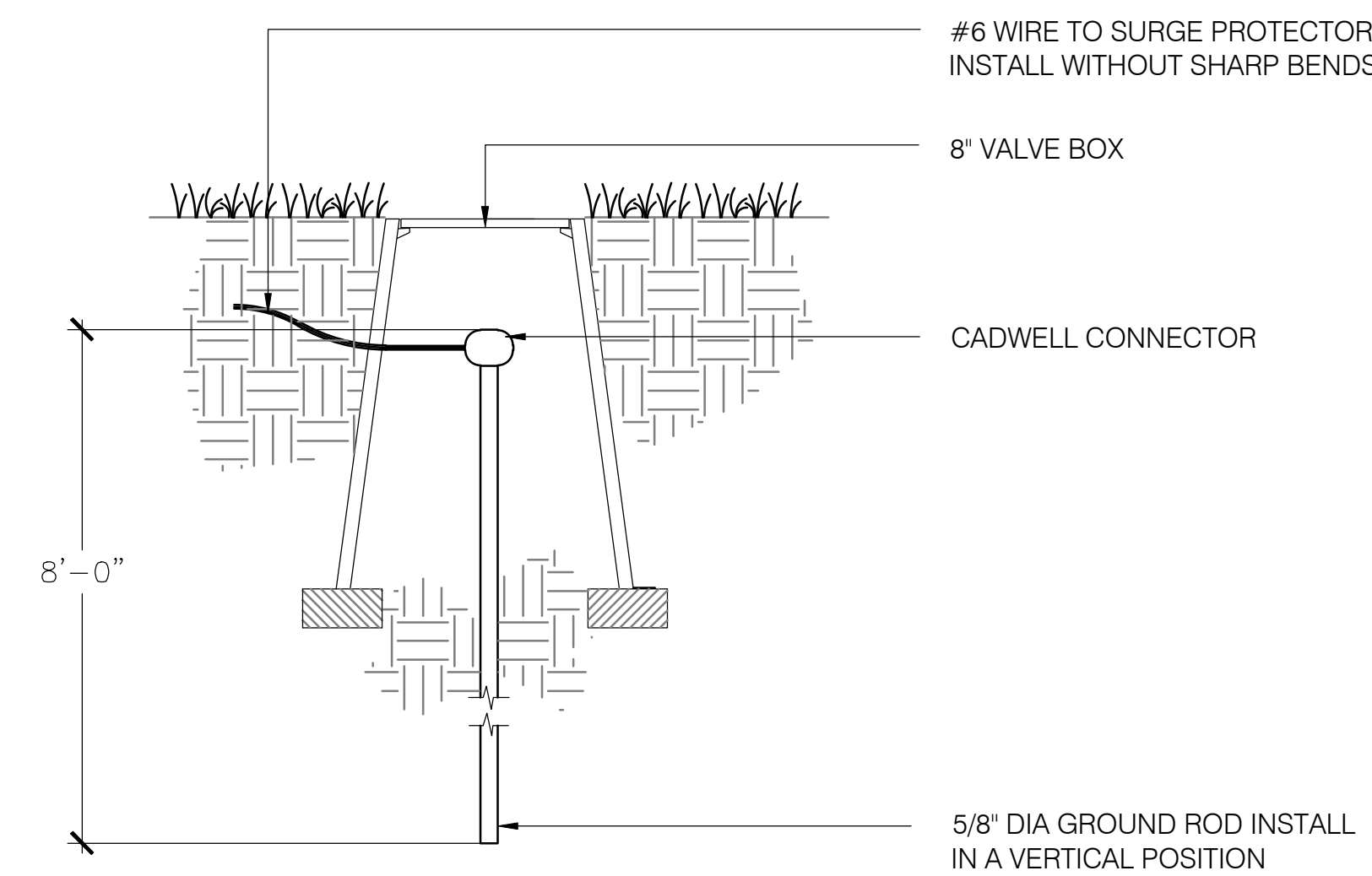
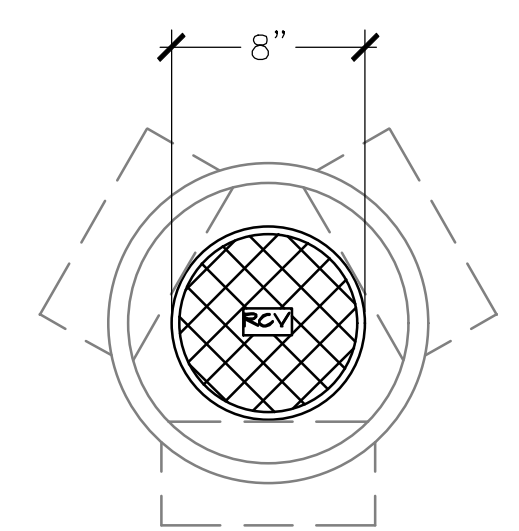

5 GROUNDING ROD
NOT TO SCALE

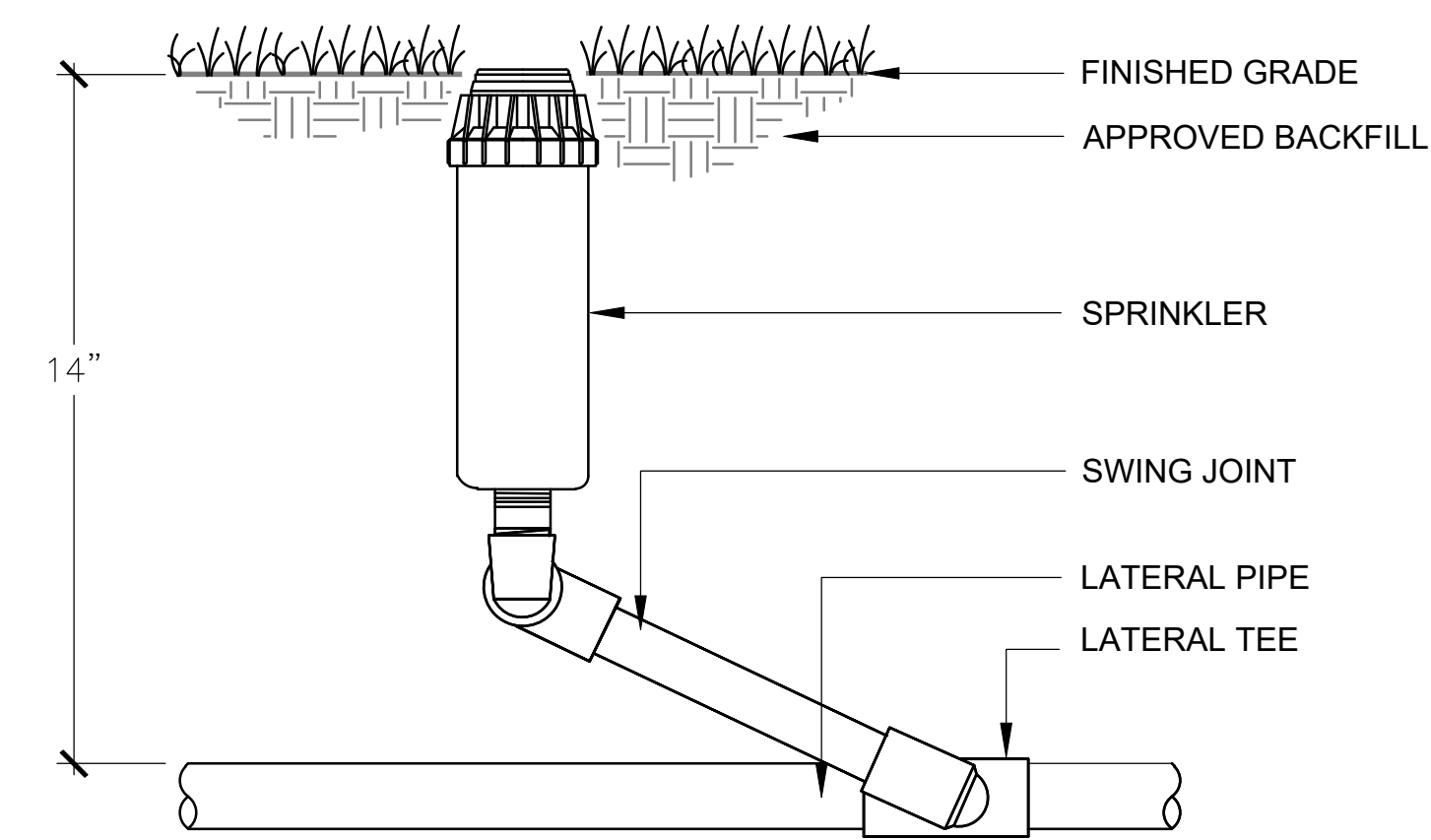

NOTE:
INSTALL SPRINKLER 1/2" A BELOW TURF

1 GEAR DRIVEN ROTOR
NOT TO SCALE

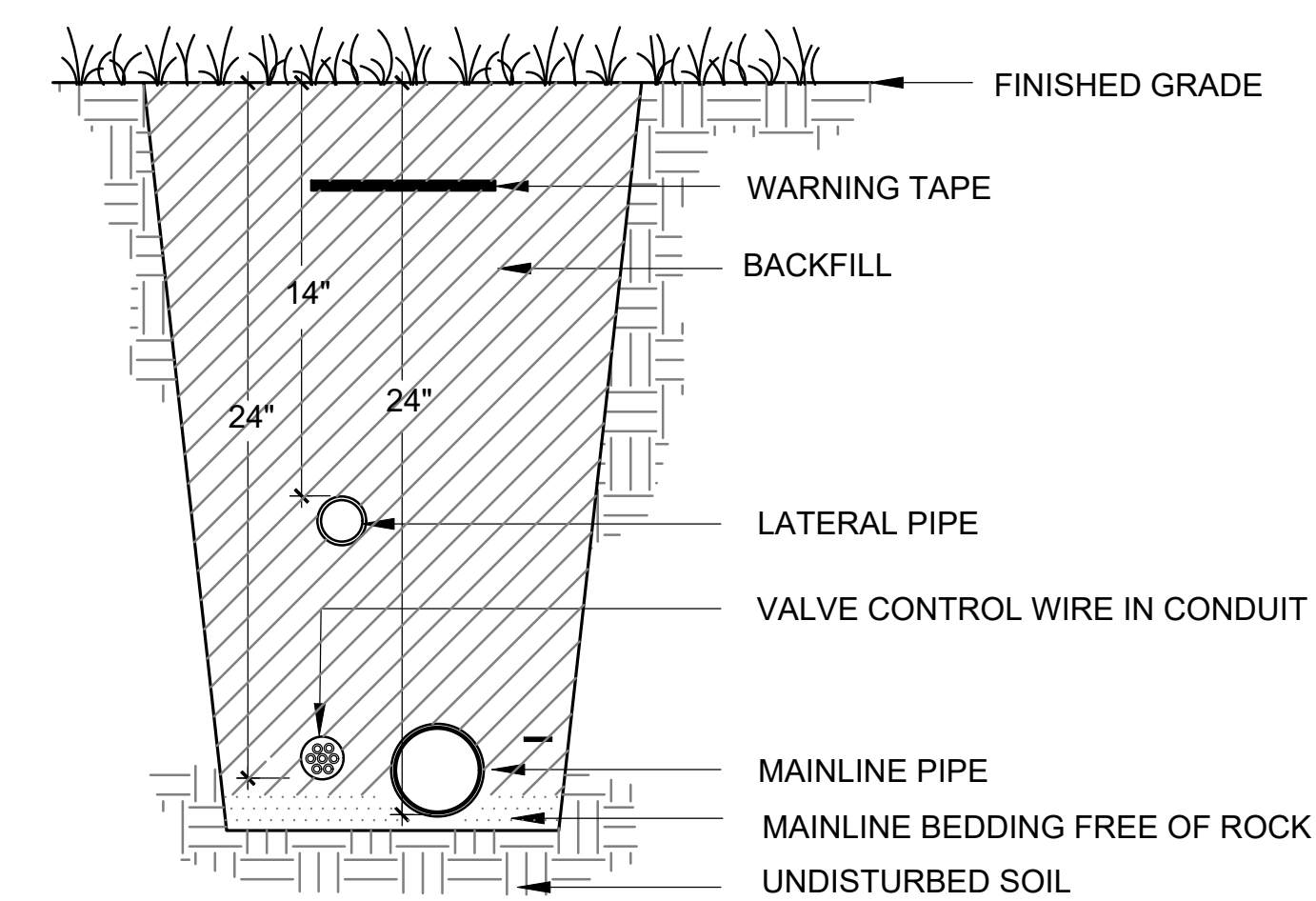

2 TYPICAL TRENCH AT LAWN
NOT TO SCALE

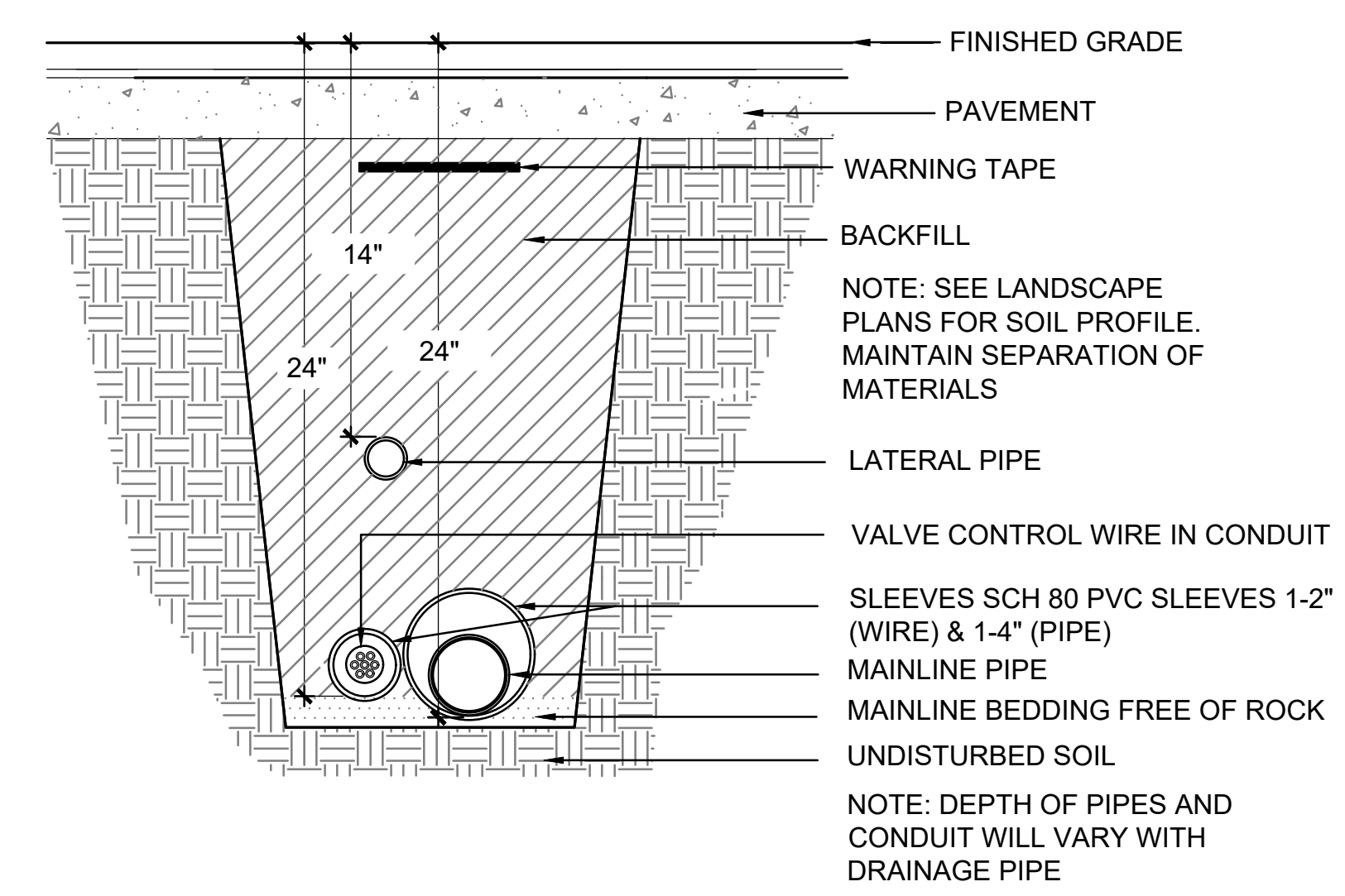

3 TYPICAL TRENCH AT PAVEMENT
NOT TO SCALE

IRRIGATION DETAILS
Kevin M. DeGobbo Memorial Field
ENGINEERING DEPARTMENT
BOROUGH OF NAUGATUCK
PROPOSED ATHLETIC FIELD AND PARKING
APPLE HILL ESTATES SUBDIVISION - SECTION 2
November 14, 2018
SHEET IR-3 OF 5

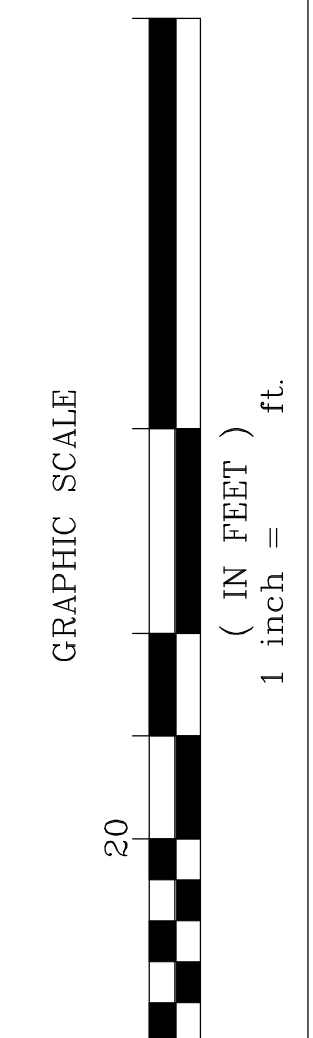

To my knowledge and belief, this map is substantially correct as noted hereon.

NO.	DATE	DESCRIPTION	BY
1.	07-07-19	Diamond size & light locations	WJZ
2.	07-14-19	ADJUST DIAMOND FOR FENCE	WJZ

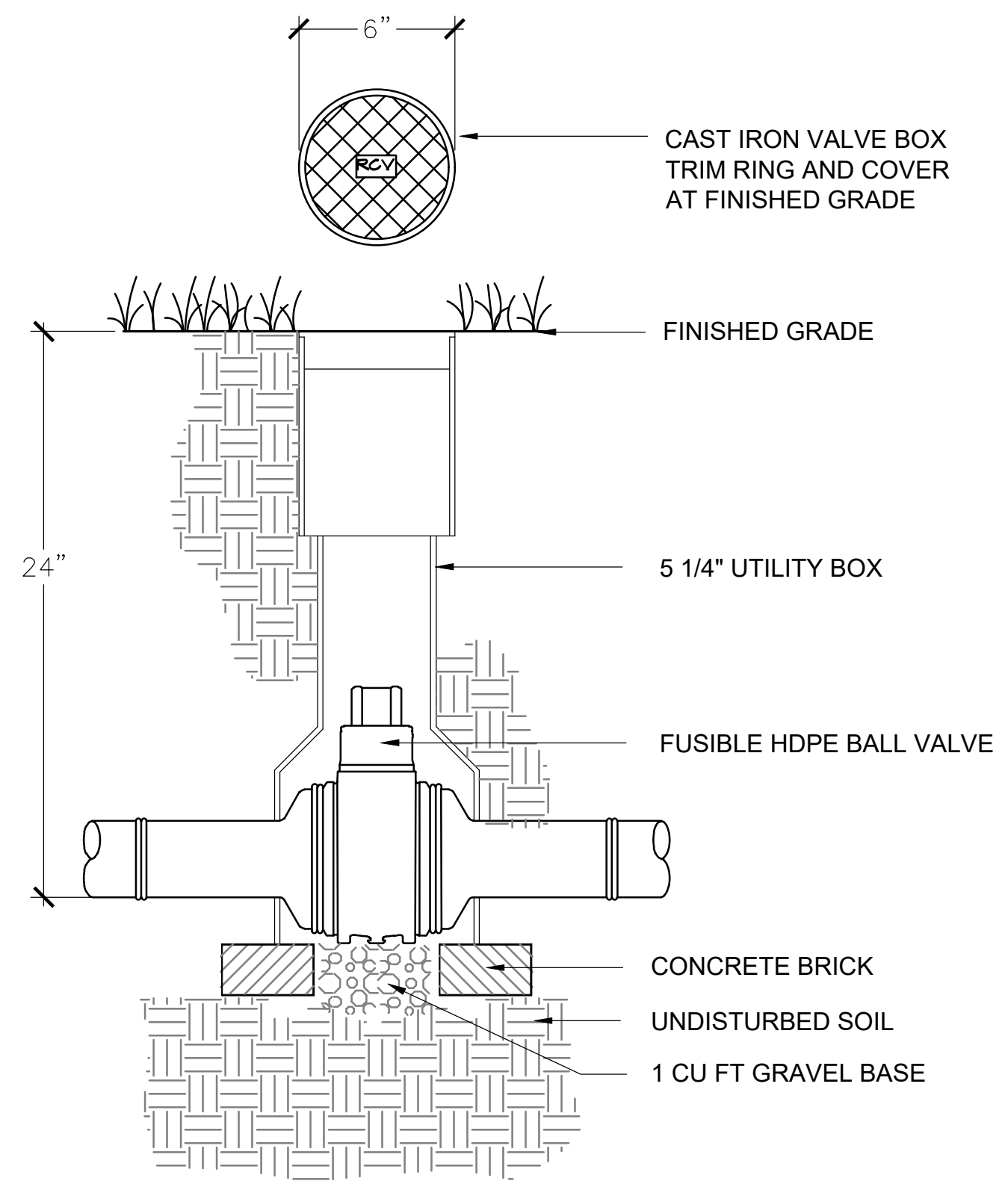

5 GATE VALVE
NOT TO SCALE

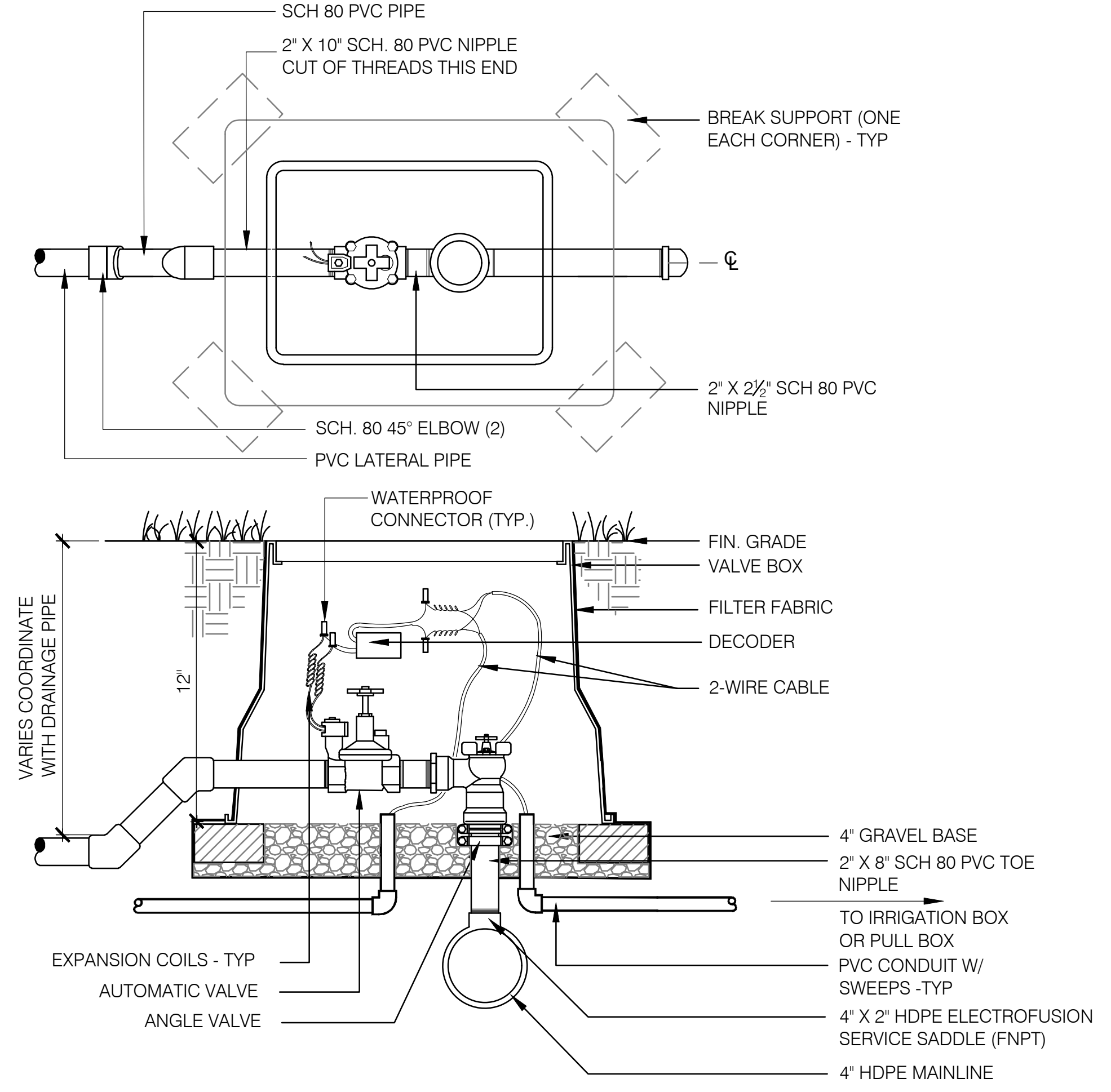

3 AUTOMATIC VALVE ASSEMBLY
NOT TO SCALE

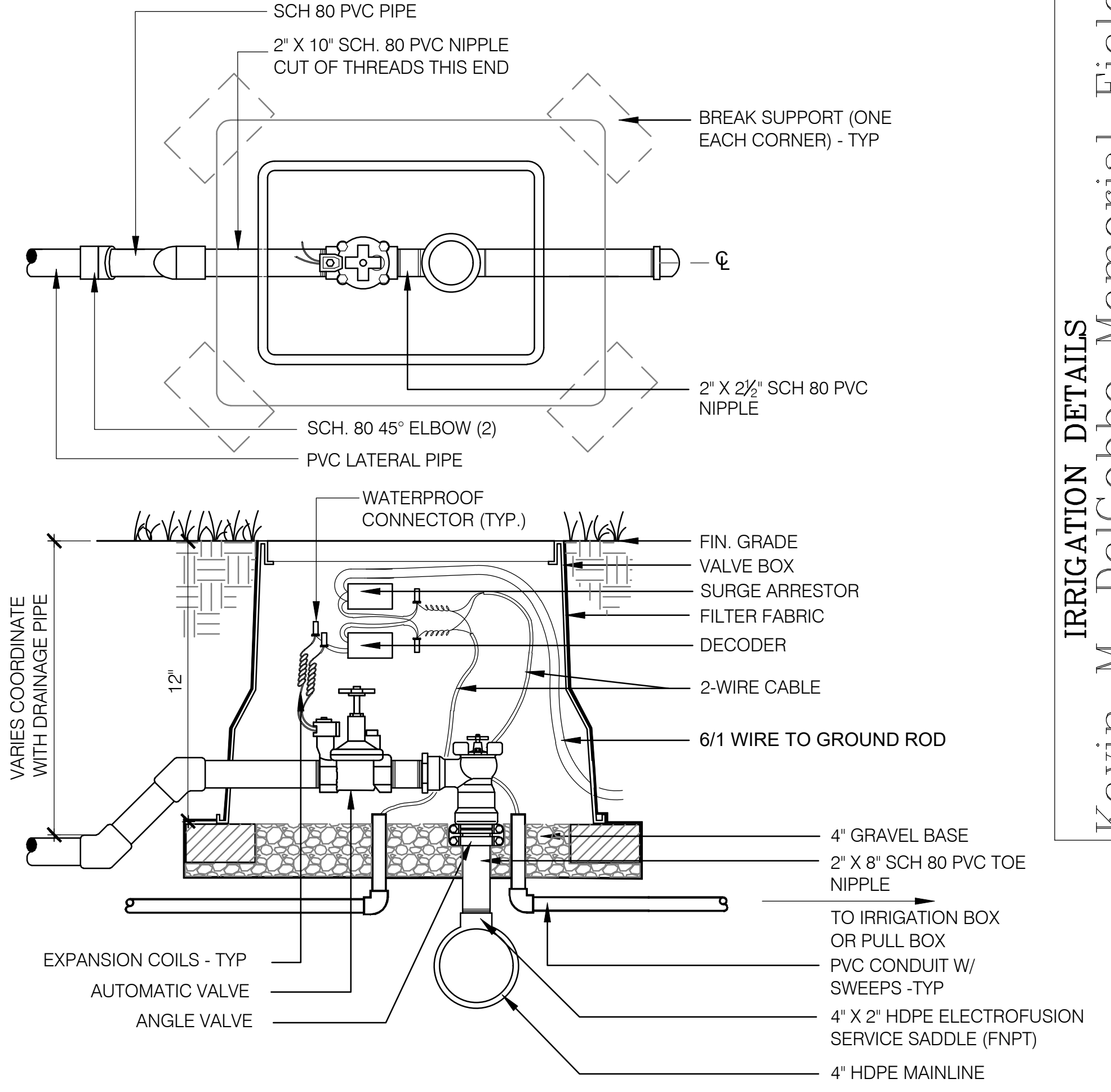

1 AUTOMATIC VALVE ASSEMBLY W/SURGE ARRESTOR
NOT TO SCALE

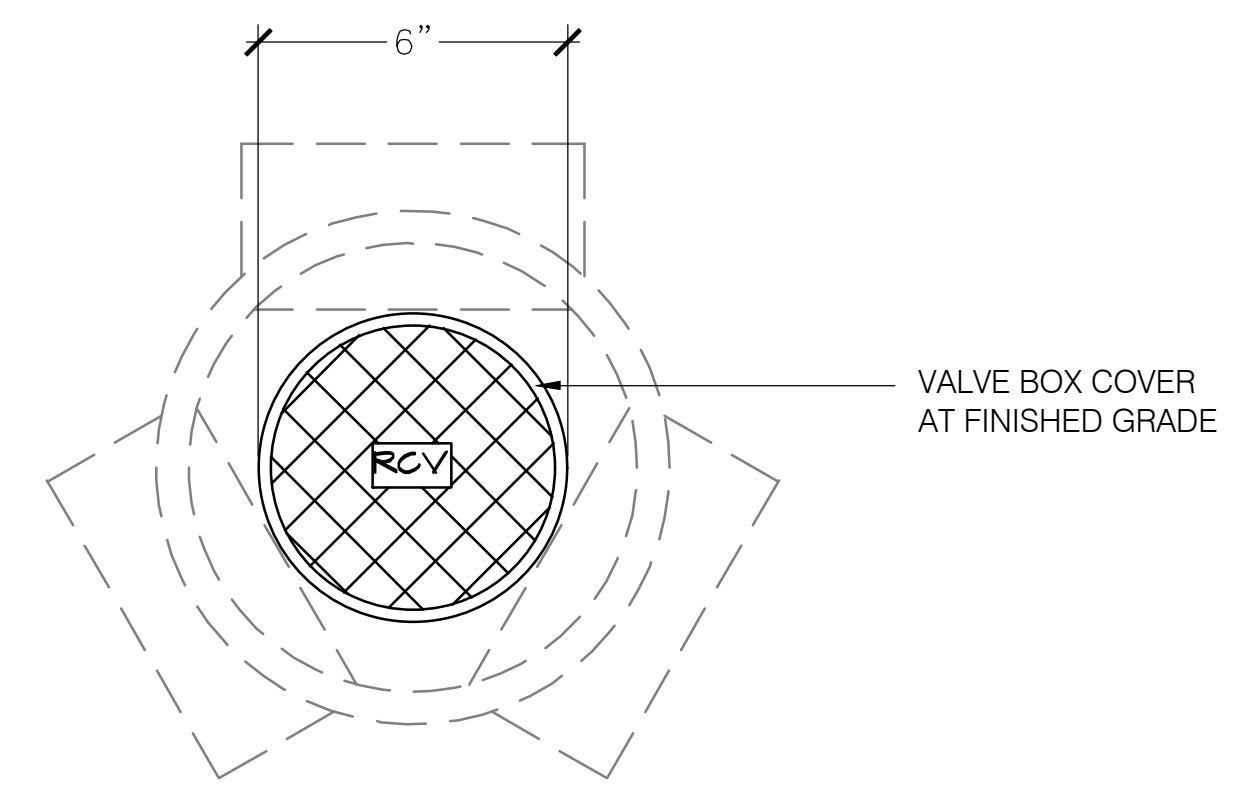

6 MOISTURE SENSOR
NOT TO SCALE

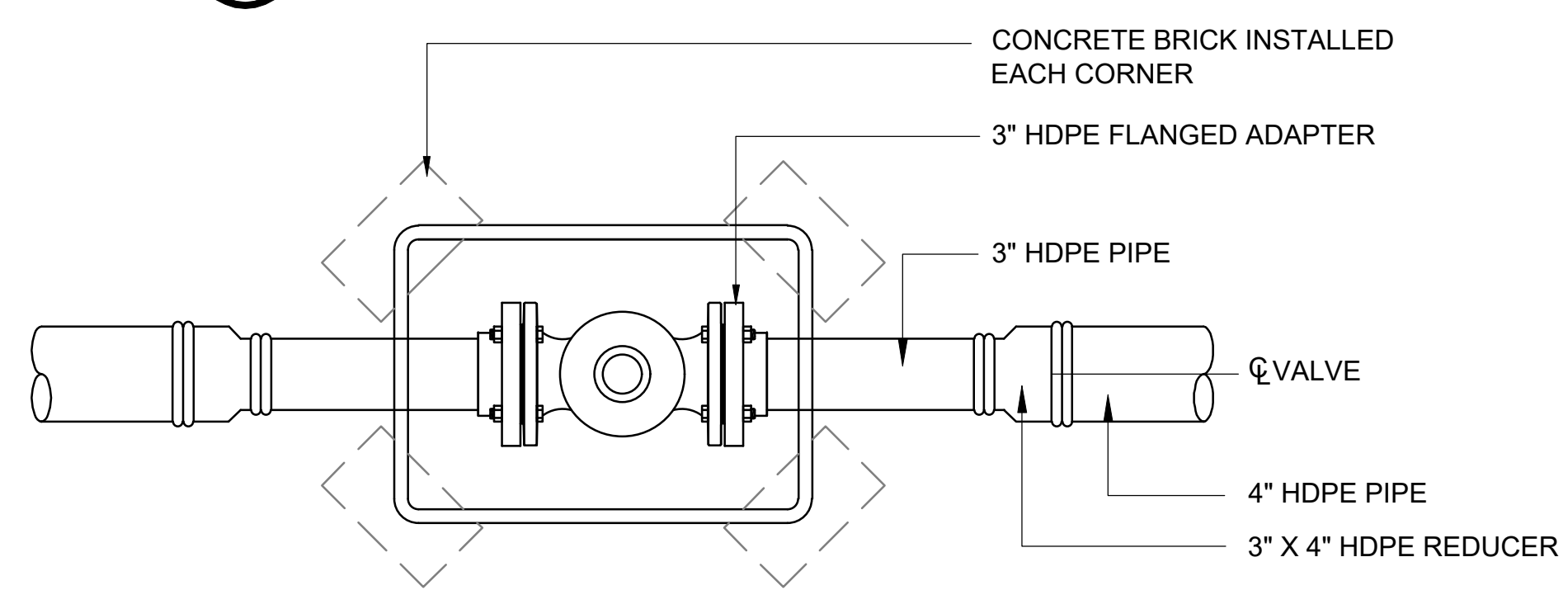

4 HYDROMETER - BASE BID
NOT TO SCALE

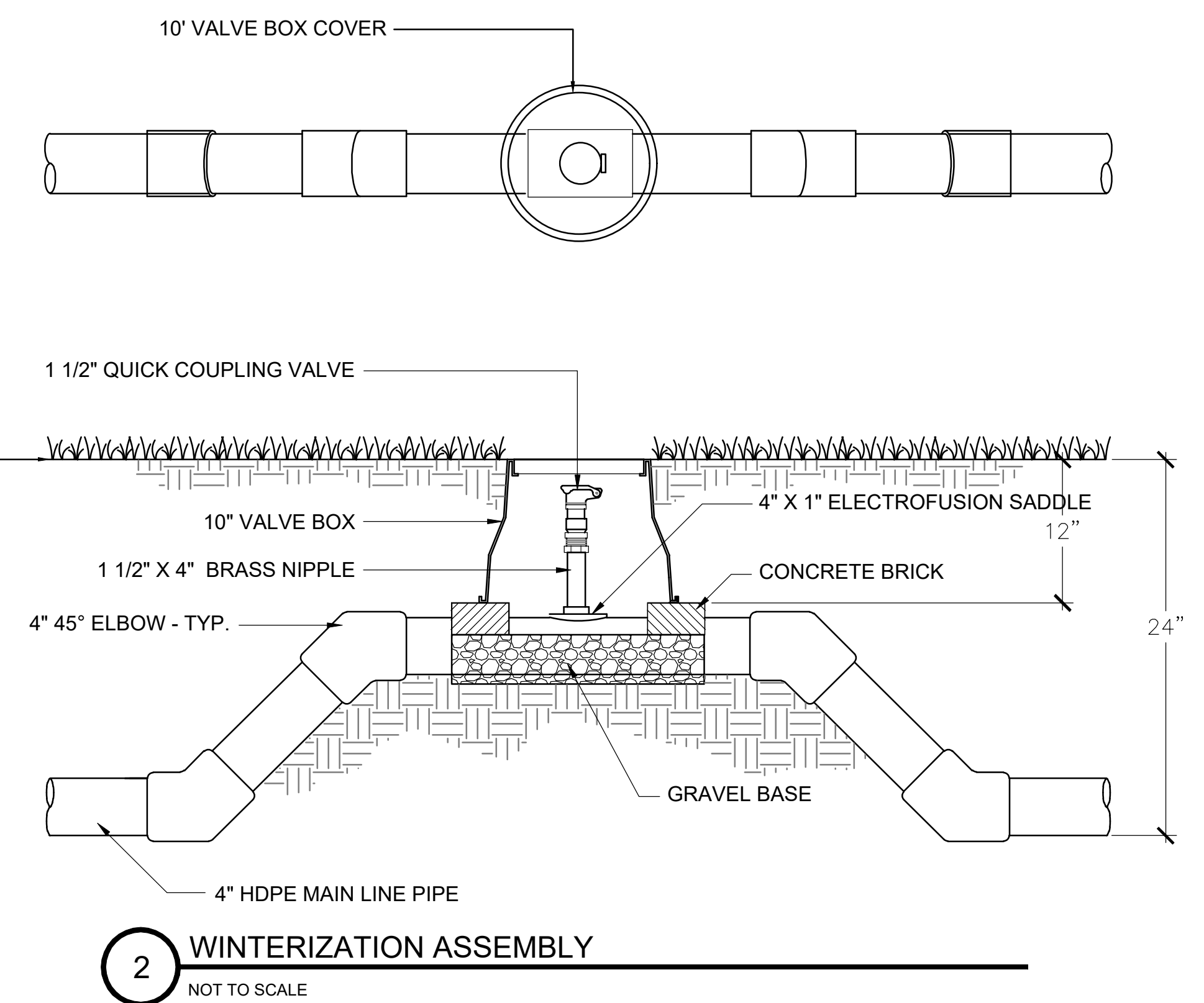
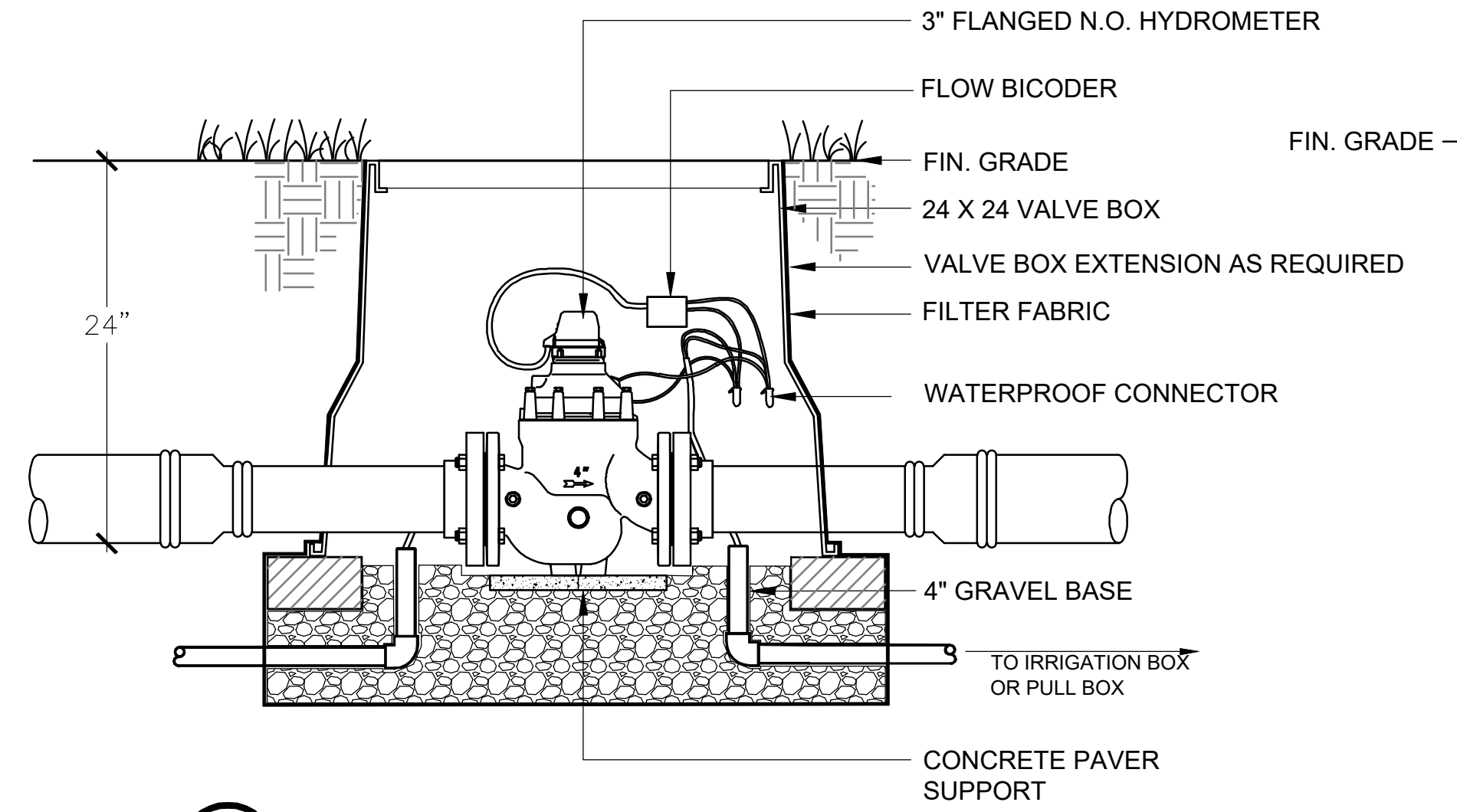
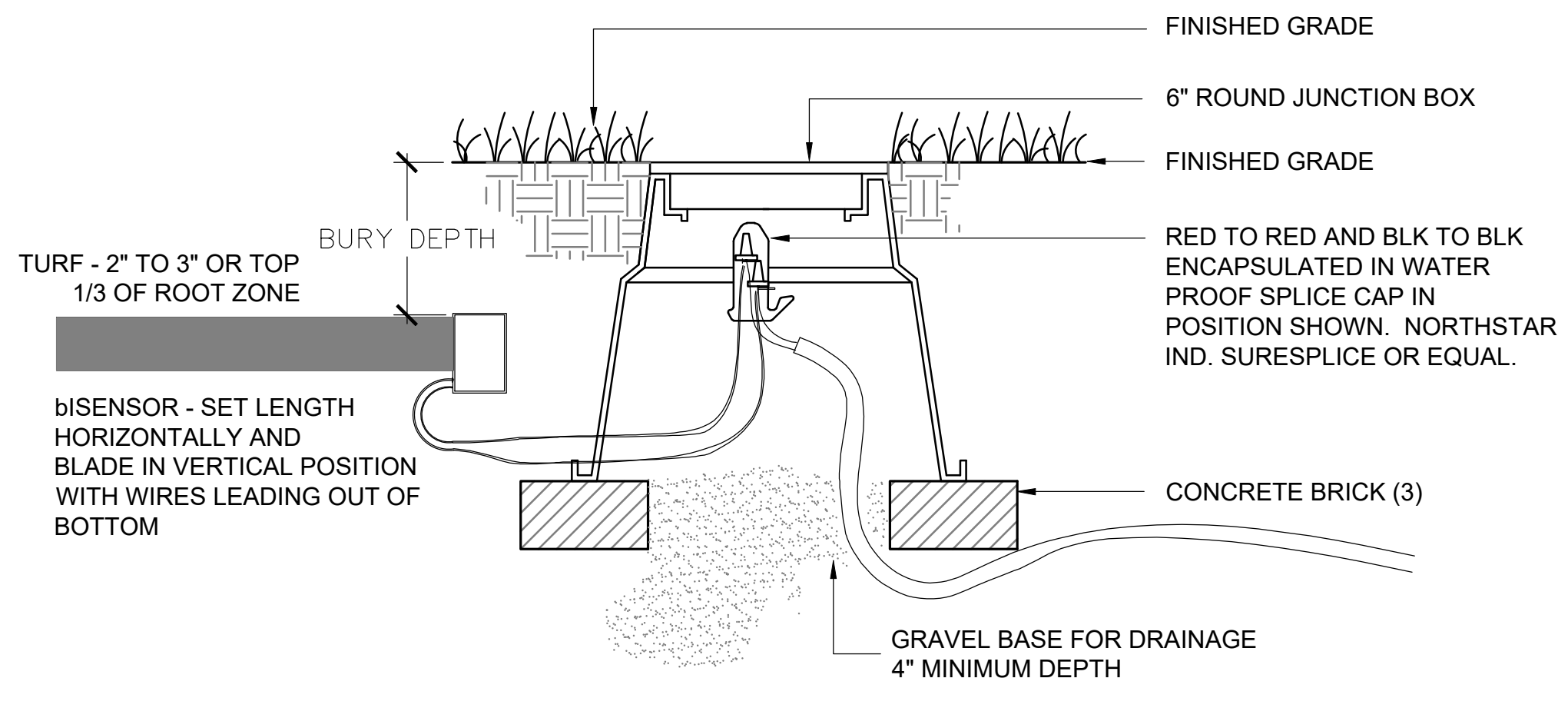

2 WINTERIZATION ASSEMBLY
NOT TO SCALE

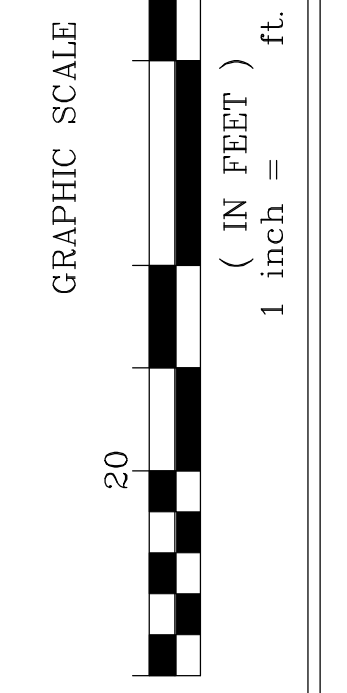

To my knowledge and belief, this map is substantially correct as noted hereon.

NO.	DATE	DESCRIPTION
1.	01-07-19	Diamond size & light locations
2.	01-14-19	ADJUST DIAMOND FOR FENCE

Wayne J. Zirolli, L.S. No. 13297

TOP VIEW

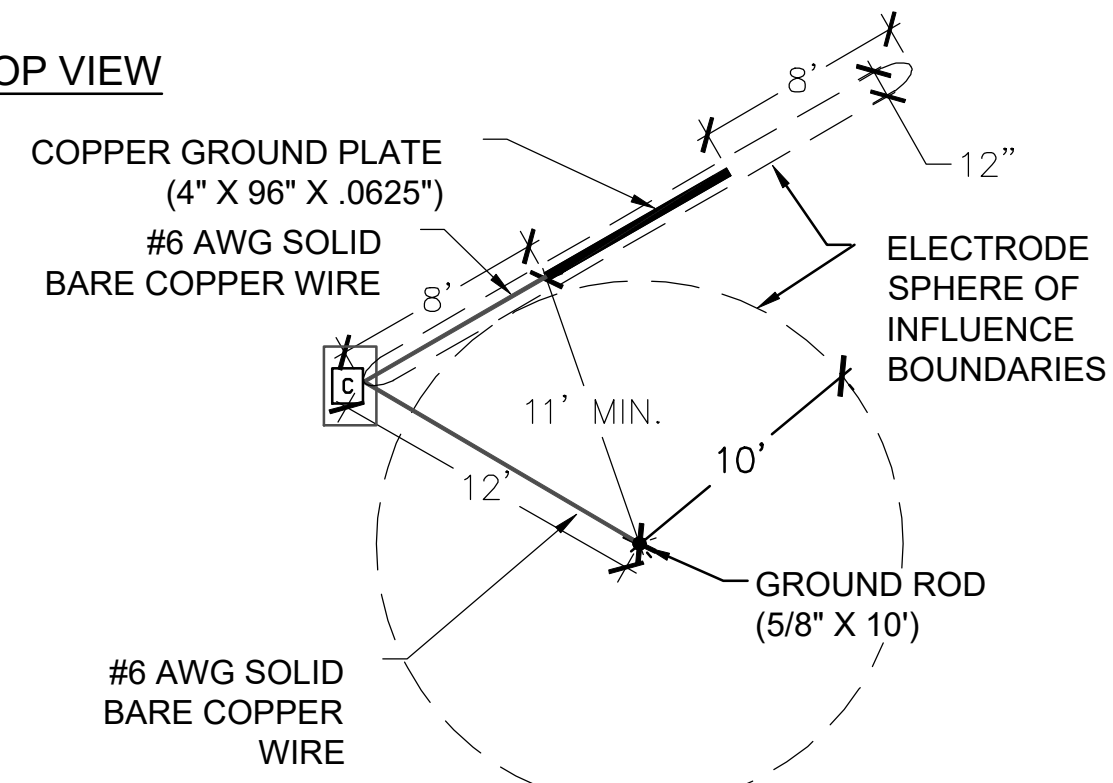

DO NOT INSTALL ANY OTHER WIRES OR CABLE WITHIN THE SPHERE OF INFLUENCE

SIDE VIEW

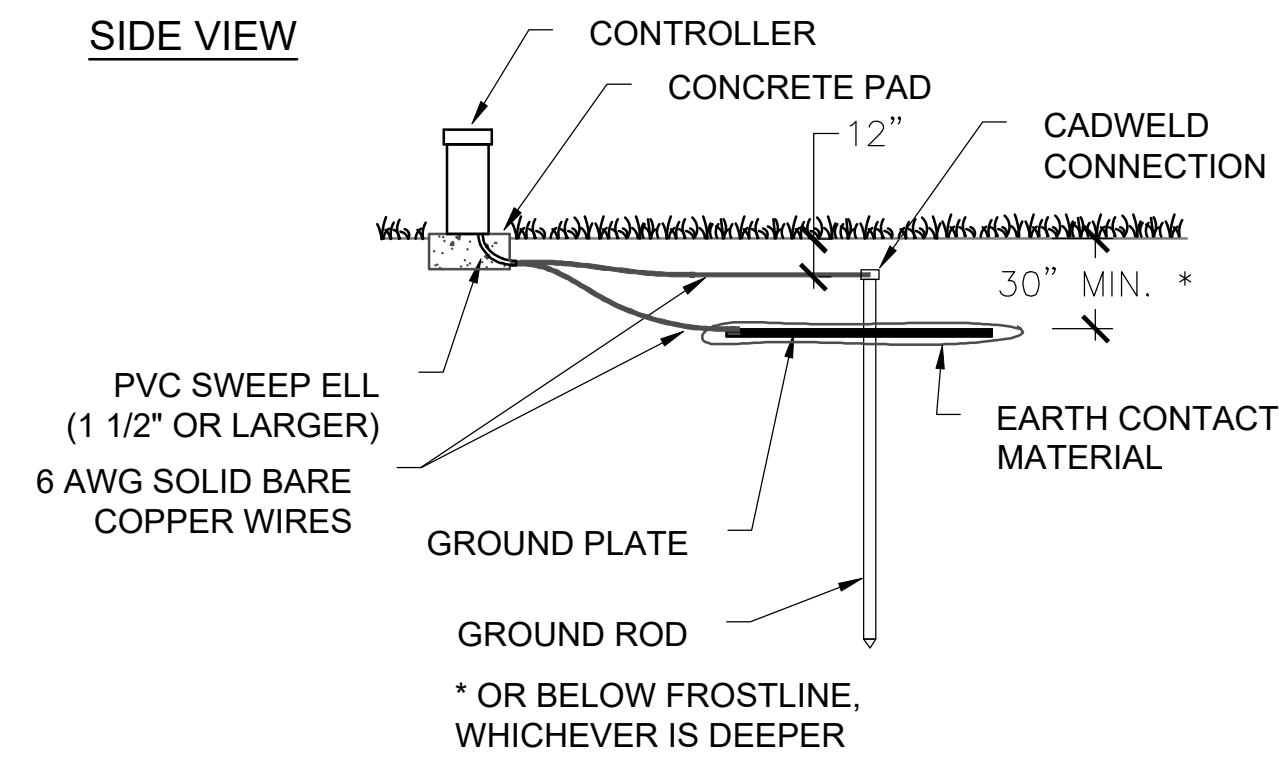

4 IRRIGATION CONTROLLER GROUNDING
NOT TO SCALE

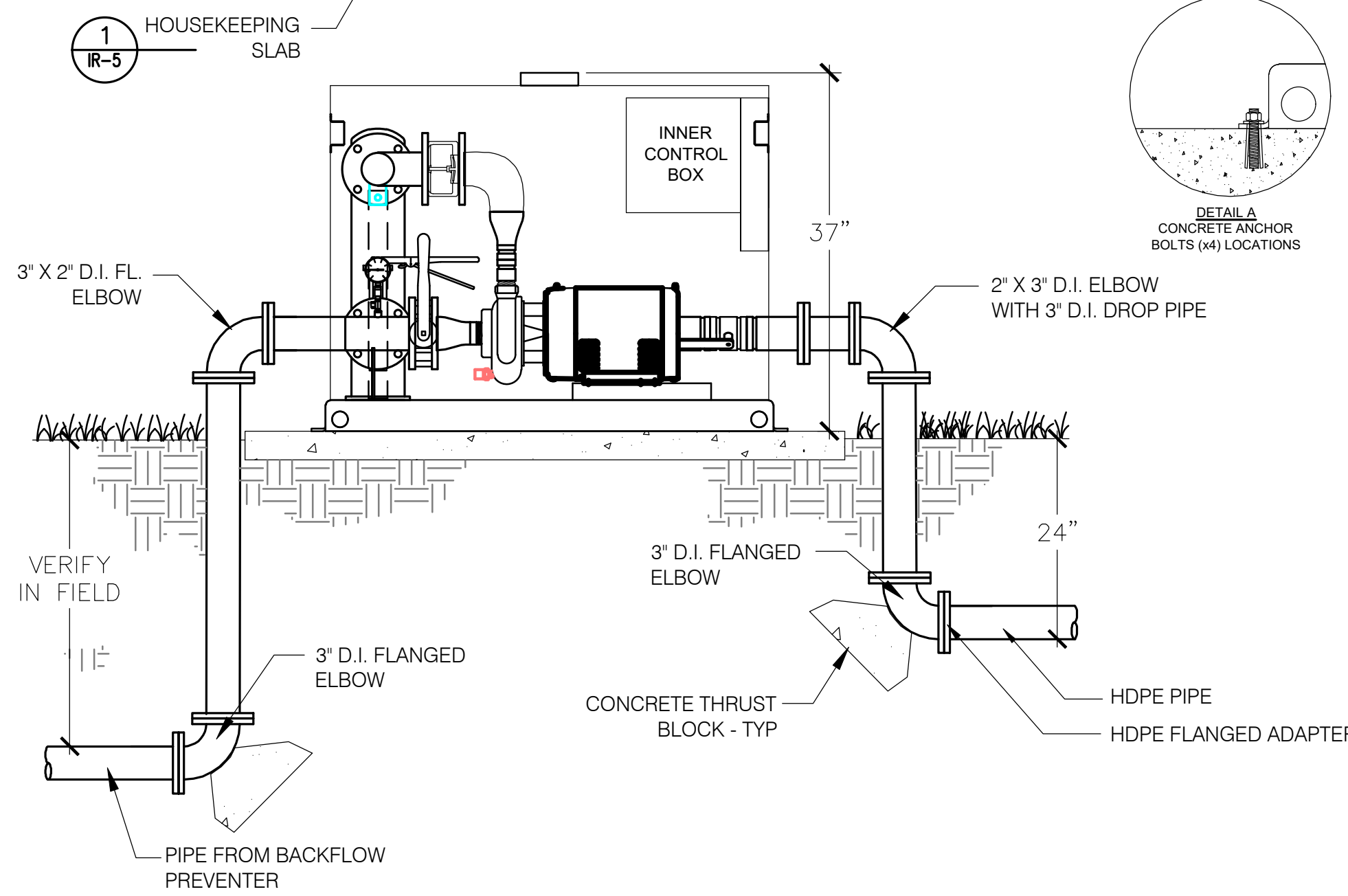
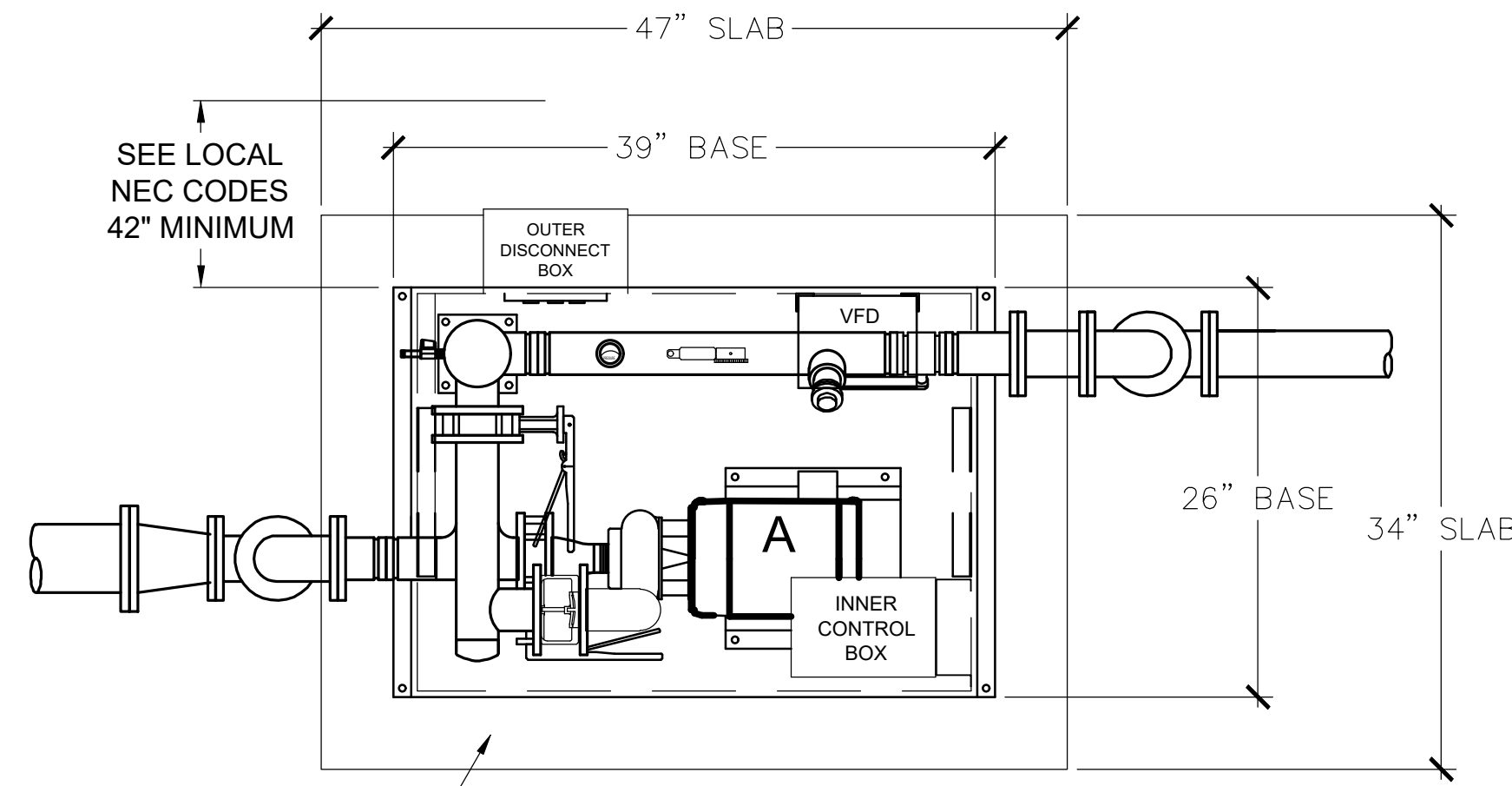

3 IRRIGATION BOOSTER PUMP - BASE BID
NOT TO SCALE

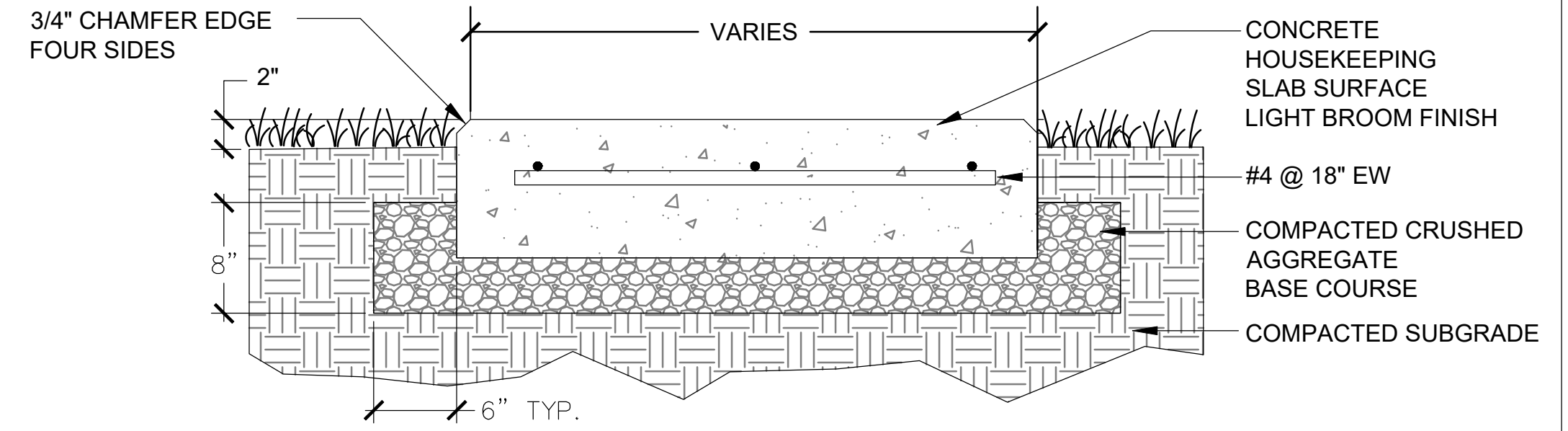

1 HOUSEKEEPING SLAB
NOT TO SCALE

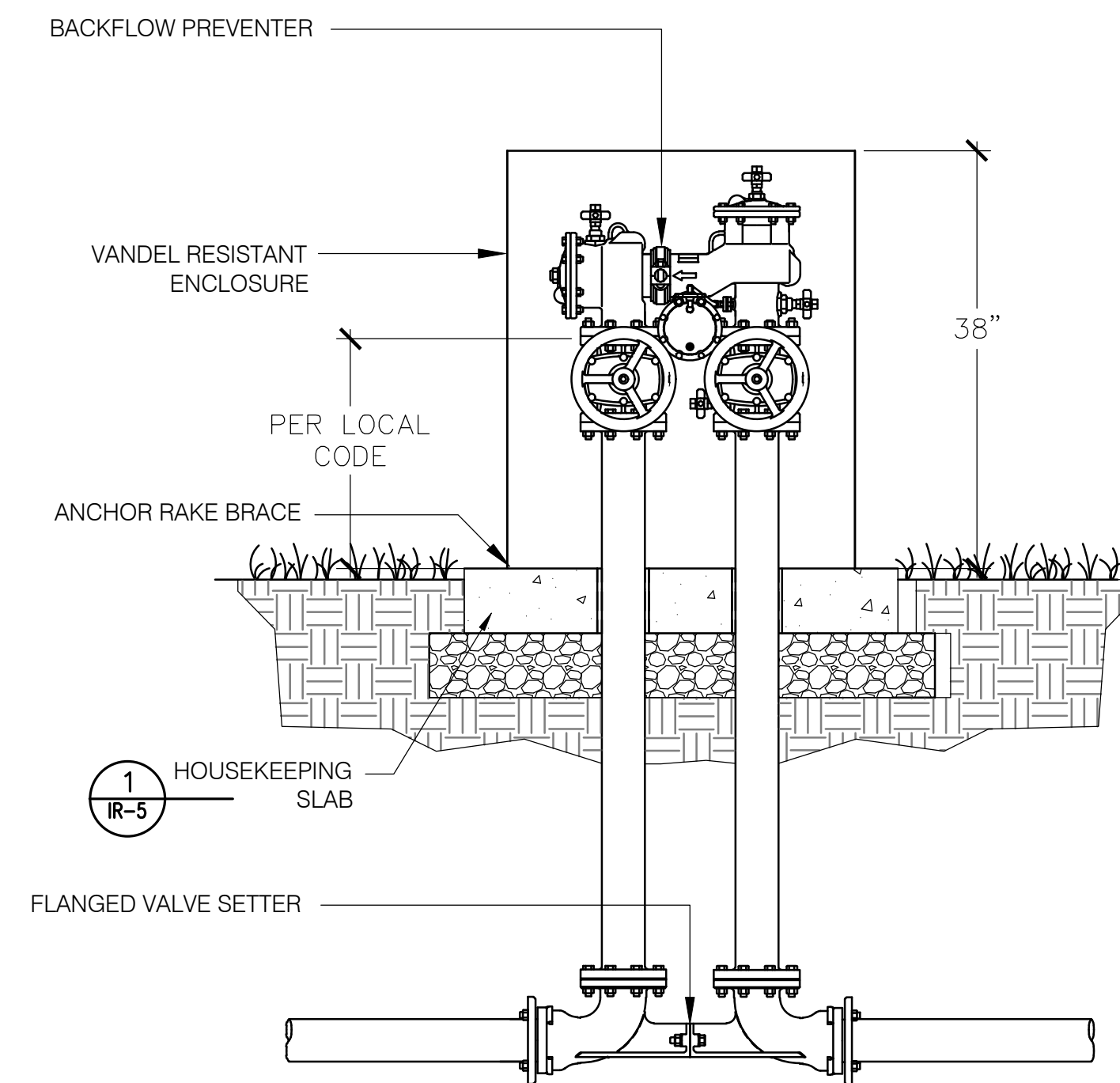

2 BACKFLOW PREVENTER
NOT TO SCALE

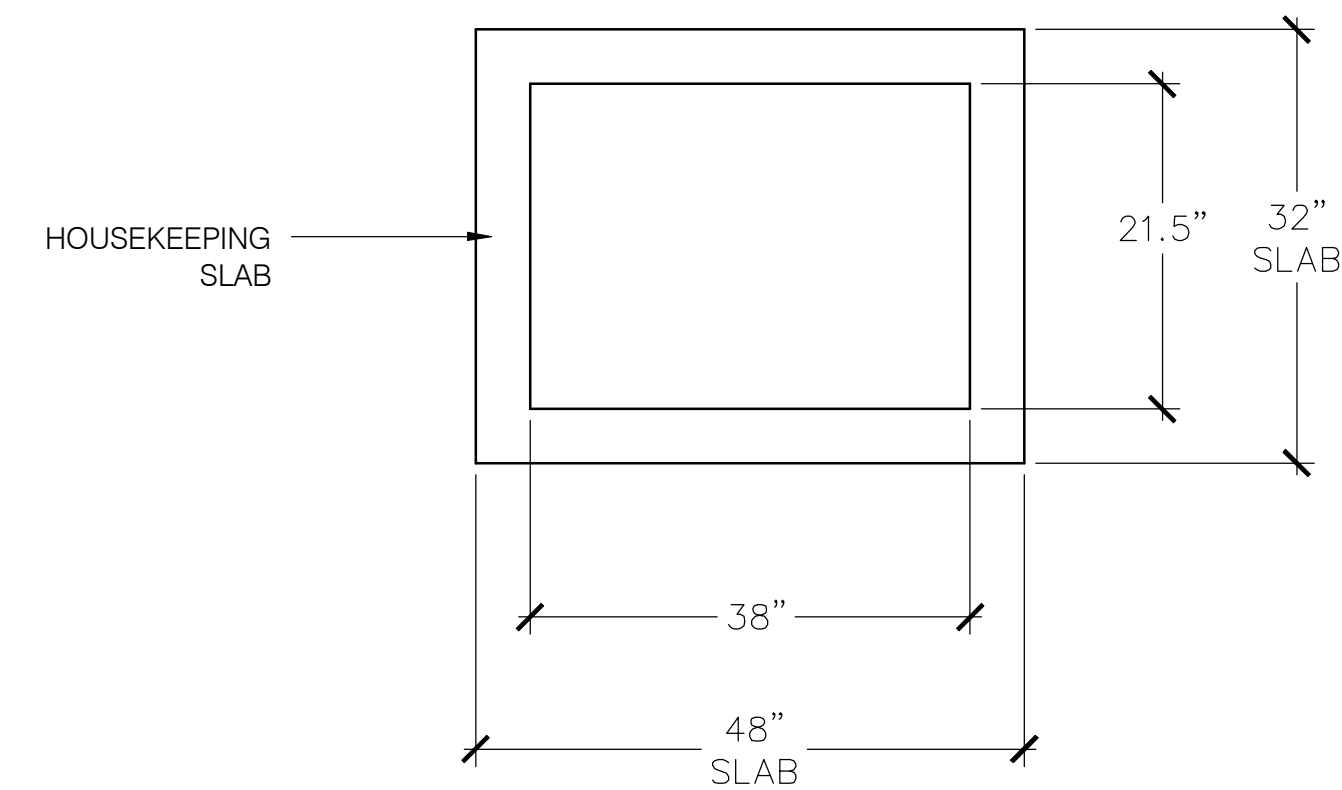

IRRIGATION DETAILS
 Kevin M. DeGobbo Memorial Field
 ENGINEERING DEPARTMENT
BOROUGH OF NAUGATUCK
 PROPOSED ATHLETIC FIELD AND PARKING
 APPLE HILL ESTATES SUBDIVISION - SECTION 2
 November 14, 2018
SHEET IR-5 OF 5

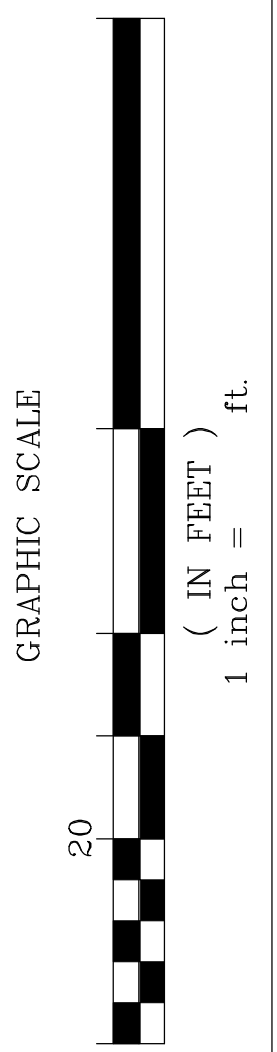

To my knowledge and belief, this map is substantially correct as noted hereon.
 Wayne J. Zirilli, L.S. No. 13297

NO.	DATE	DESCRIPTION	BY
1.	01-07-19	Diamond size & light locations	W/J
2.	01-14-19	ADJUST DIAMOND FOR FENCE	W/J

SECTION J

Field Ledge Location

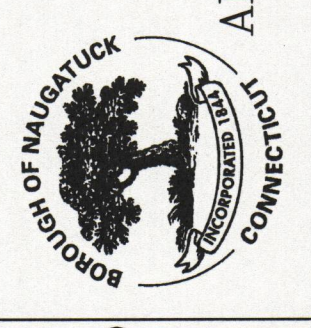

THIS MAP IS NOT VALID UNLESS SIGNED AND EMBOSSED WITH THE SEAL OR AFFIXED WITH THE LIVE STAMP OF THE SIGNATORY. COPIES, REPRODUCTIONS, OR ANY OTHER REPRESENTATIONS OF THIS DOCUMENT ARE UNAUTHORIZED.

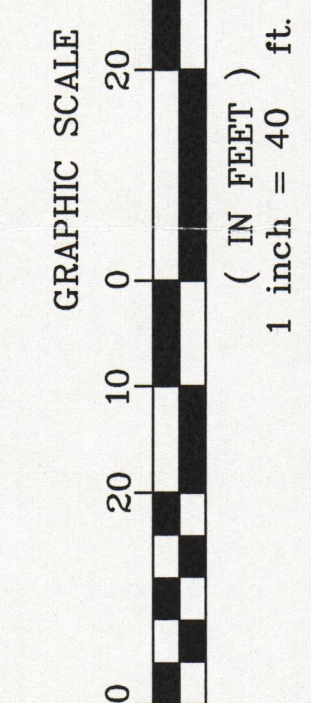

Wayne J. Zirolli, I.S. No. 13297

NO.	DATE	DESCRIPTION	BY
1.	01-07-19	Diamond size & light locations	WJZ
2.	01-14-19	ADJUST DIAMOND FOR FENCE	WJZ
3.	09-19-19	ADJUST LIGHTING LOCATIONS	WJZ

- SHARK - WHEN DO WE NEED PAVEMENT
- FINISHES FOR AMOUNTS
- RECURS CENTER PLANTS
- CLP CONSULTANT
- WHITFENCES ASSETS

NOTES:
 1. THIS SURVEY AND MAP HAS BEEN PREPARED PURSUANT TO THE REGULATIONS OF CONNECTICUT STATE AGENCIES SECTIONS 20-300B-1 THROUGH 20-300B-20 AND THE "STANDARDS FOR SURVEYS AND MAPS IN THE STATE OF CONNECTICUT" AS ADOPTED BY THE CONNECTICUT ASSOCIATION OF LAND SURVEYORS, INC. ON SEPTEMBER 26, 1996. IT IS A COMPILATION PLAN. THIS PLAN WAS COMPILED FROM OTHER MAPS RECORD RESEARCH OR OTHER SOURCES OF INFORMATION. IT IS NOT TO BE CONSTRUED AS HAVING BEEN OBTAINED AS THE RESULT OF A FIELD SURVEY, AND IS SUBJECT TO CHANGE AS AN ACCURATE SURVEY MAY DISCLOSE.

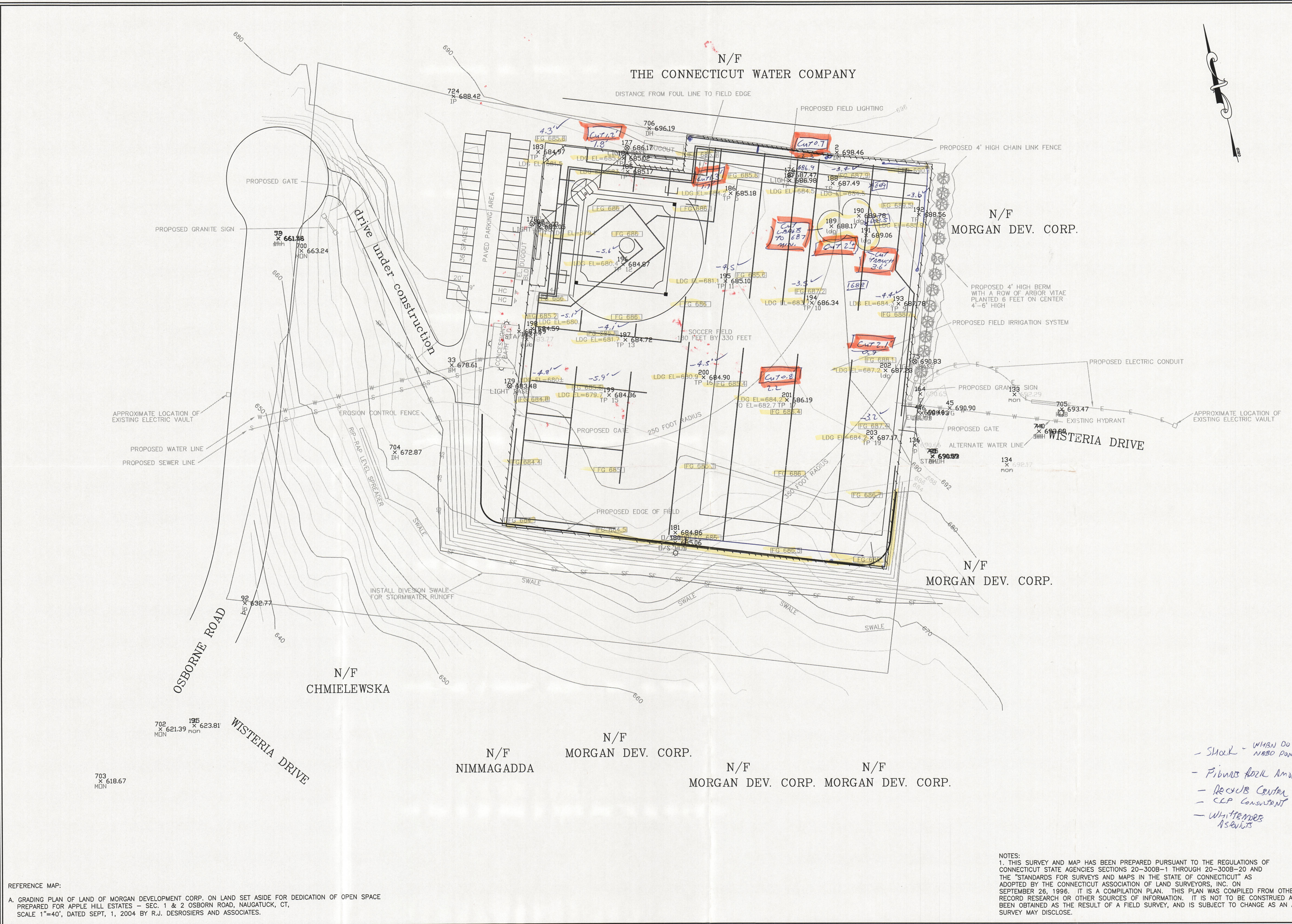

REFERENCE MAP:
 A. GRADING PLAN OF LAND OF MORGAN DEVELOPMENT CORP. ON LAND SET ASIDE FOR DEDICATION OF OPEN SPACE PREPARED FOR APPLE HILL ESTATES - SEC. 1 & 2 OSBORN ROAD, NAUGATUCK, CT, SCALE 1"=40', DATED SEPT, 1, 2004 BY R.J. DESROSIERIS AND ASSOCIATES.